



Chipsmall Limited consists of a professional team with an average of over 10 year of expertise in the distribution of electronic components. Based in Hongkong, we have already established firm and mutual-benefit business relationships with customers from,Europe,America and south Asia,supplying obsolete and hard-to-find components to meet their specific needs.

With the principle of “Quality Parts,Customers Priority,Honest Operation,and Considerate Service”,our business mainly focus on the distribution of electronic components. Line cards we deal with include Microchip,ALPS,ROHM,Xilinx,Pulse,ON,Everlight and Freescale. Main products comprise IC,Modules,Potentiometer,IC Socket,Relay,Connector.Our parts cover such applications as commercial,industrial, and automotives areas.

We are looking forward to setting up business relationship with you and hope to provide you with the best service and solution. Let us make a better world for our industry!



Contact us

Tel: +86-755-8981 8866 Fax: +86-755-8427 6832

Email & Skype: info@chipsmall.com Web: www.chipsmall.com

Address: A1208, Overseas Decoration Building, #122 Zhenhua RD., Futian, Shenzhen, China





Hand Crimp Tool Specification Sheet Order No. 63811-2400

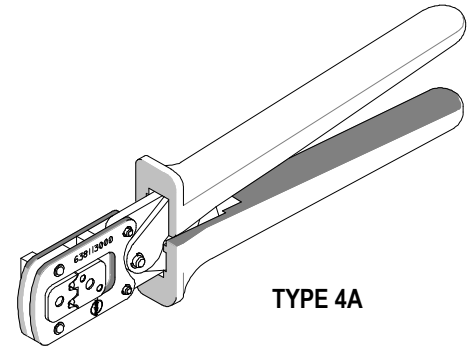

FEATURES

- % A full cycle ratcheting hand tool ensures complete crimps
- % Ergonomically designed soft handles
- % Precisely designed crimping profiles with simple contact positioning
- % Easy handling due to outstanding force ratio

SCOPE

Products: 1.50mm (.591") Pitch, MX150™ Blade Male Crimp Terminals, 14-16 AWG.

Terminal Series No.	Terminal Order No.		Wire Size		Insulation Diameter		Strip Length	
	● Reel		AWG	mm ²	mm	In.	mm	In.
33000	33000-0001	33000-1001	14	2.00	2.54-2.69	.100-.106	4.70-5.60	.185-.220
	33000-0002	33000-1002	16	1.27	2.18-2.34	.086-.092	4.70-5.60	.185-.220
33011	33011-0001	33011-0002	14	2.00	2.54-2.69	.100-.106	4.70-5.60	.185-.220
	33011-1002	33011-2003						
	33011-3003							
	33011-0003	33011-0004	16	1.27	2.18-2.34	.086-.092	4.70-5.60	.185-.220
	33011-1004	33011-2002						
	33011-3002							

● Customer to cut off terminal from reel: 0.10mm (.010") maximum Cut-off Tab.
 Terminals were validated per USCAR-21 using the following wire specifications:
 M1L-123A (TXL), M1L-135A1 (UTX), and M1L-126A1 (metric-TXL).
 Customers are required to complete validation testing if tooling purchased outside Molex Inc.
 and / or wire specifications are different than above.

DEFINITION OF TERMS

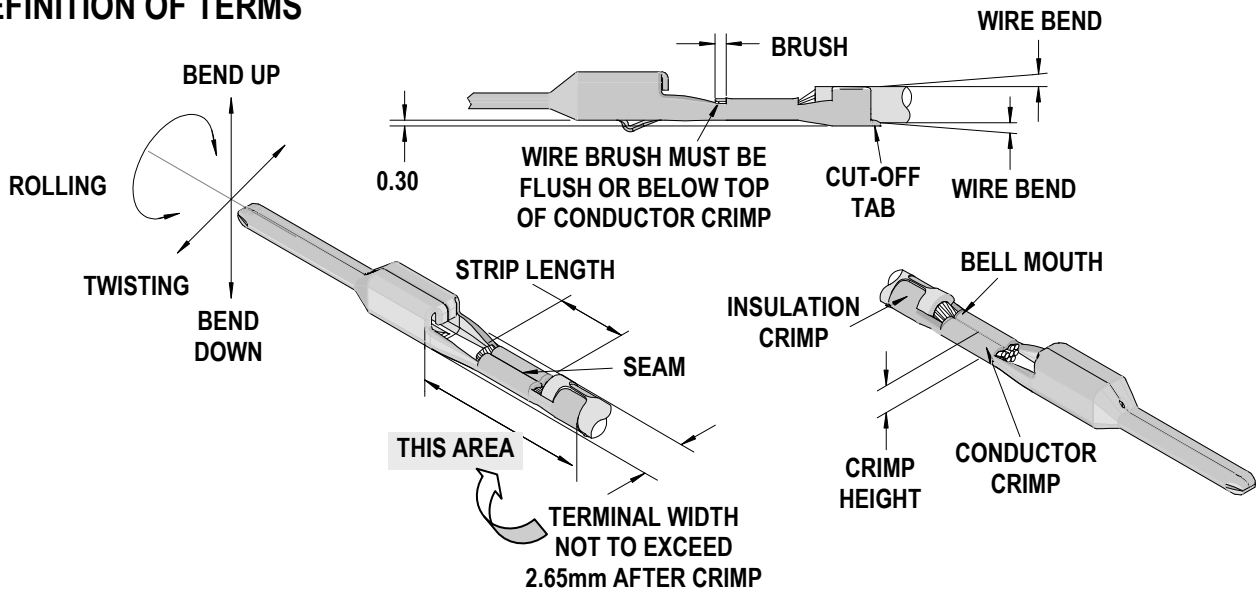

CONDITIONS:

After crimping, the crimp profiles should measure the following (see notes on page 4).

Terminal Series No.	Bell mouth		* Conductor Brush		Bend up	Bend Down	Twist	Roll
	mm	In.	mm	In.	Degree		Degree	
33000	0.25-1.25	.010-.049	0.15-0.65	.006-.026	3	3	3	5
33011	0.25-1.25	.010-.049	0.15-0.65	.006-.026	3	3	3	5

* Wire brush must be flush or below top of Conductor Crimp.

Terminal Series No.	Wire Size		Conductor Crimp				Profile AWG	
			Height		Width			
	AWG	mm ²	mm	In.	mm	In.	16	14
33000	14	2.00	1.60-1.70	.063-.067	2.35-2.55	.093-.100		X
	16	1.27	1.30-1.40	.051-.055	2.05-2.25	.081-.089	X	
33011	14	2.00	1.60-1.70	.063-.067	2.35-2.55	.093-.100		X
	16	1.27	1.30-1.40	.051-.055	2.05-2.25	.081-.089	X	

Terminal Series No.	Wire Size		Insulation Crimp				Pull Force Minimum	
			Height		Width			
	AWG	mm ²	mm	In.	mm	In.	N	Lb.
33000	14	2.00	2.70-2.90	.106-.114	2.70-2.90	.106-.114	180.0	40.50
	16	1.27	2.10-2.30	.083-.091	2.50-2.70	.098-.106	120.0	27.00
33011	14	2.00	2.70-2.90	.106-.114	2.70-2.90	.106-.114	180.0	40.50
	16	1.27	2.10-2.30	.083-.091	2.50-2.70	.098-.106	120.0	27.00

OPERATION

Open the tool by squeezing the handles together, at the end of the closing stroke, the ratchet mechanism will release the handles, and the hand tool will spring open.

Crimping Terminals

1. Lift the wire stop blades up.
2. Insert the terminal fully into the correct die profile and the locator slot until the terminal is fully seated and stops.
3. Bring down the wire stop blades. Make sure the wire stop blades are fully seated on the terminal behind the conductor grip section.
4. Slide the pre-stripped wire into the terminal; make sure to aim the wire brush towards the tip point on the wire stop blade. See Figure 1. Align the wire so that it is parallel and sitting into the terminal. Maintain a light and constant pressure on the wire that is seated in the terminal at all times. (Do not let go of the wire.) Be sure to hold the wire and terminal in place until the terminal is fully crimped. See Figure 2.

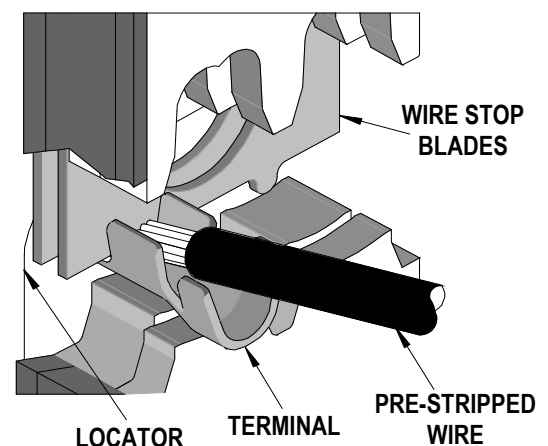

Figure 1

5. Close the tool until the ratchet releases.
6. Lift the wire stop blades up.
7. Carefully remove the crimped terminal.

Note: To maintain a good brush control and a consistent bell mouth the crimping instructions must be followed.

Maintenance

It is recommended that each operator of the tool be made aware of, and responsible for, the following maintenance steps:

1. Remove dust, moisture, and other contaminants with a clean brush, or soft, lint free cloth.
2. Do not use any abrasive materials that could damage the tool.
3. Make certain all pins; pivot points and bearing surfaces are protected with a thin coat of high quality machine oil. Do not oil excessively.
4. When tool is not in use, keep the handles closed to prevent objects from becoming lodged in the crimping dies, and store the tool in a clean, dry area.

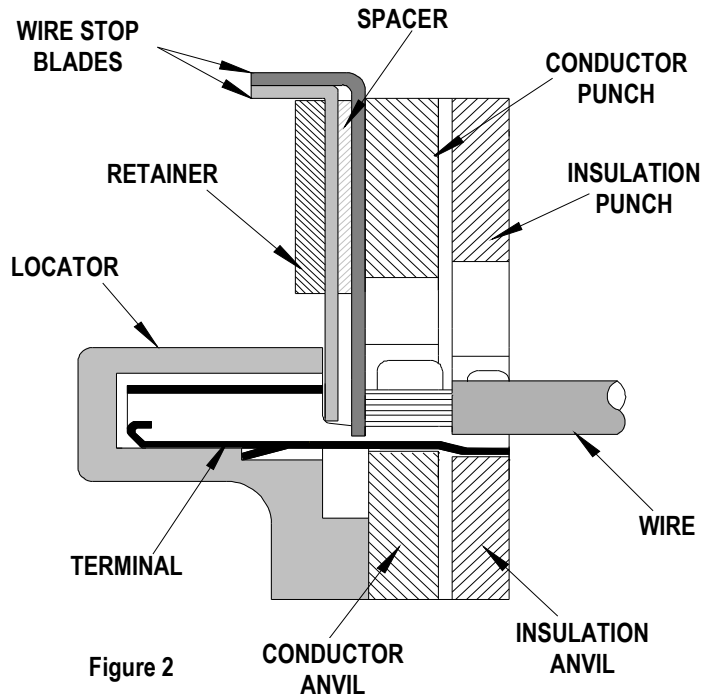

Figure 2

Miscrimps or Jams (See Figure 3)

Should this tool ever become stuck or jammed in a partially closed position, **Do Not** force the handles open or closed. The tool will open easily by pushing the ratchet release lever.

Warranty

This tool is for electrical terminal crimping purposes only. This tool is made of the best quality materials. All vital components are long life tested. All tools are warranted to be free of manufacturing defects for a period of 30 days. Should such a defect occur, we will repair or exchange the tool free of charge. This repair or exchange will not be applicable to altered, misused, or damaged tools. This tool is designed for hand use only. Any clamping, fixturing, or use of handle extensions voids this warranty.

CAUTION: Molex crimp specifications are valid only when used with Molex terminals and tooling.

Notes:

1. This tool should only be used for the terminals and wire gauges specified on this sheet.
2. This tool is not adjustable for crimp height, however crimp force is adjustable (See instructions above). Variations in tools, terminals, wire stranding and insulation types may affect crimp height.
3. This tool is intended for standard conductor sizes. It may not give a good insulation crimp support for all insulation sizes.
4. Molex does not repair hand tools (see warranty above). The replacement parts listed are the only parts available for repair. If the handles or crimp tooling is damaged or worn, a new tool must be purchased.
5. Pull force should be used as the final criteria for an acceptable crimp. Pull force is measured with no influence from the insulation crimp. The insulation should be stripped long (1/2 in.), so the insulation grips on the terminal do not grip the wire insulation or the conductor. Refer to Molex Quality Crimping Handbook 63800-0029 for additional information on crimping and crimp testing.
6. Molex does not certify crimp hand tools.
7. Hand held crimping tools are intended for low volume, prototyping, or repair requirements only.

CAUTION: Repetitive use of this tool should be avoided.

PARTS LIST

Item Number	Order Number	Description	Quantity
1	63600-0520	Crimping Spring	2
2	63811-2475	Locator	1
3	63600-0525	Handle Spring	1

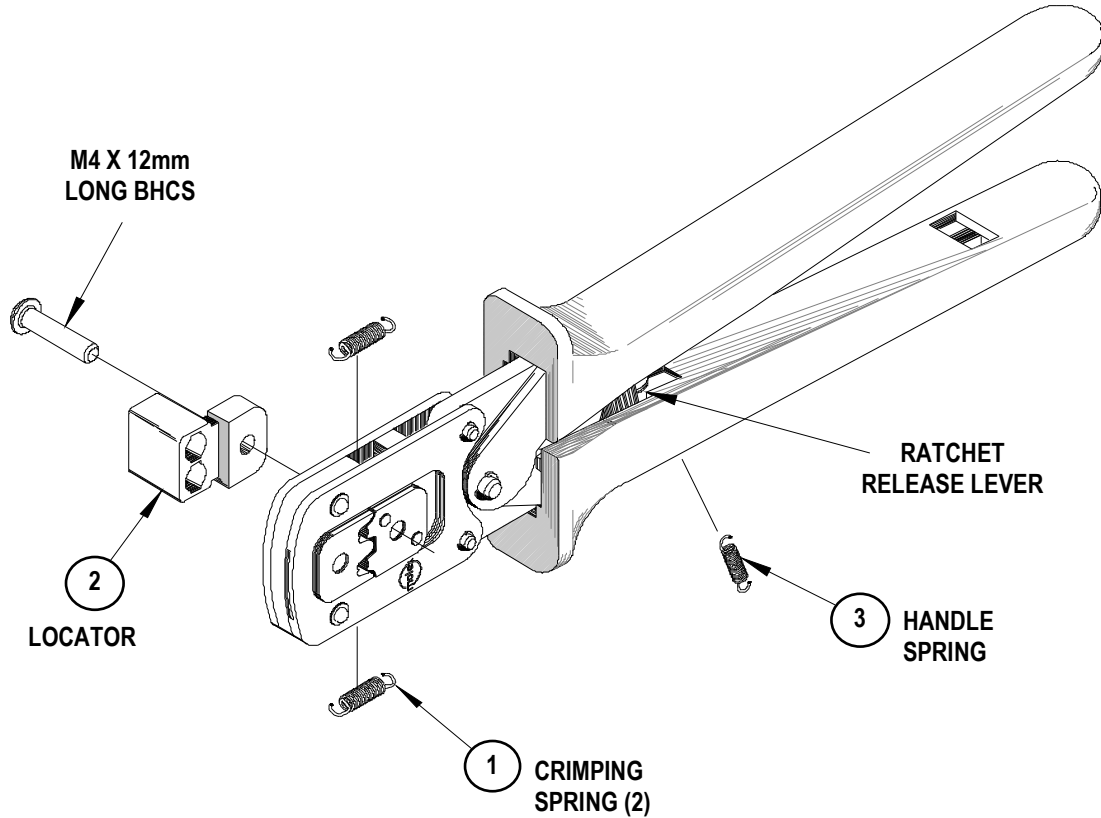

Figure 3

Americas Headquarters
 Lisle, Illinois 60532 U.S.A.
 1-800-78MOLEX
 amerinfo@molex.com

Far East North Headquarters
 Yamato, Kanagawa, Japan
 81-462-65-2324
 feninfo@molex.com

Far East South Headquarters
 Jurong, Singapore
 65-6-268-6868
 fesinfo@molex.com

European Headquarters
 Munich, Germany
 49-89-413092-0
 eurinfo@molex.com

Corporate Headquarters
 2222 Wellington Ct.
 Lisle, IL 60532 U.S.A.
 630-969-4550
 Fax: 630-969-1352

Visit our Web site at <http://www.molex.com>