



Chipsmall Limited consists of a professional team with an average of over 10 year of expertise in the distribution of electronic components. Based in Hongkong, we have already established firm and mutual-benefit business relationships with customers from,Europe,America and south Asia,supplying obsolete and hard-to-find components to meet their specific needs.

With the principle of “Quality Parts,Customers Priority,Honest Operation,and Considerate Service”,our business mainly focus on the distribution of electronic components. Line cards we deal with include Microchip,ALPS,ROHM,Xilinx,Pulse,ON,Everlight and Freescale. Main products comprise IC,Modules,Potentiometer,IC Socket,Relay,Connector.Our parts cover such applications as commercial,industrial, and automotives areas.

We are looking forward to setting up business relationship with you and hope to provide you with the best service and solution. Let us make a better world for our industry!



Contact us

Tel: +86-755-8981 8866 Fax: +86-755-8427 6832

Email & Skype: info@chipsmall.com Web: www.chipsmall.com

Address: A1208, Overseas Decoration Building, #122 Zhenhua RD., Futian, Shenzhen, China



THIS DRAWING IS UNPUBLISHED. RELEASED FOR PUBLICATION ,19 .
 © COPYRIGHT 19 BY AMP INCORPORATED. ALL INTERNATIONAL RIGHTS RESERVED.

LOC		DIST		REVISIONS			
ZONE	LTR	DESCRIPTION	DATE	APPD			
AF	50			C	REVISED PER 063A-0451-00	24JUL00	MF/KR

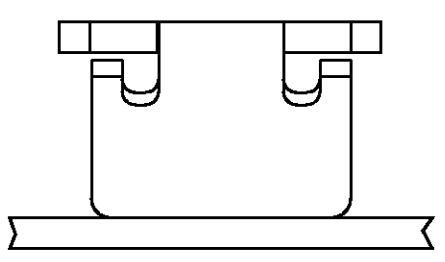

- 1 CONTINUOUS STRIP ON REELS (NO SPLICES) WITH TERMINALS LOCATED ON 5.59±0.08 [.220±.003] CENTERS.
- 2 SLOT ACCEPTS 0.36-0.51mm [#27-#24] AWG COPPER MAGNET WIRE. SINGLE OR DOUBLE WIRE OF THE SAME SIZE AND TYPE.
- 3 GAGING: G0, 0.241 [.0095] NO/G0, 0.318 [.0125]. FREE STATE AND GAP AT CARRIER SIDE TO BE MAINTAINED PER CHART PROVIDED.

FREE STATE	CARRIER GAP
2.95-3.12 [.116-.123]	0.25-0.35 [.010-.014]
3.15 [.124]	0.28-0.35 [.011-.014]
3.18 [.125]	0.30-0.35 [.012-.014]
3.20 [.126]	0.33-0.35 [.013-.014]
3.23 [.127]	0.35 [.014]

CARRIER SIDE GAP 0.25-0.35 [.010-.014] TO BE CHECKED WHEN FREE STATE IS COMPRESSED TO 3.12 [.123].

- 4 NO CRACKS OR TEARS PERMISSIBLE ALONG SHEAR AND BEND LINE

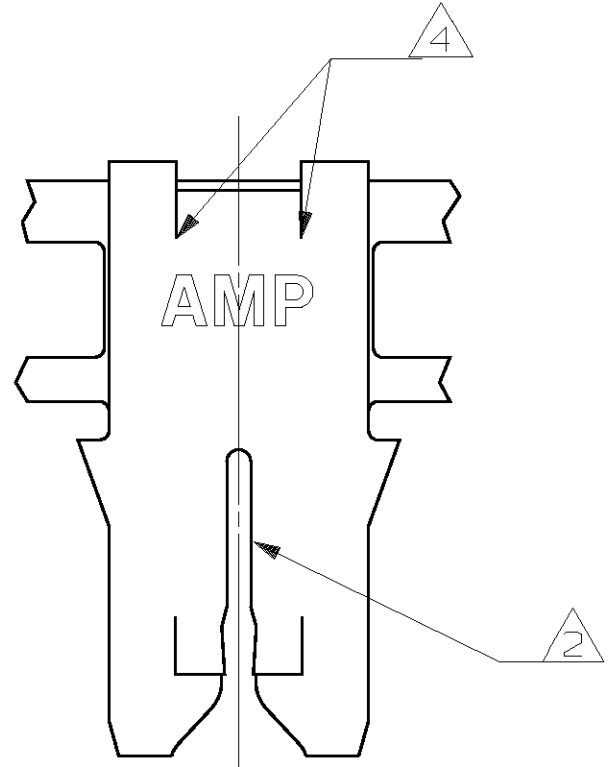
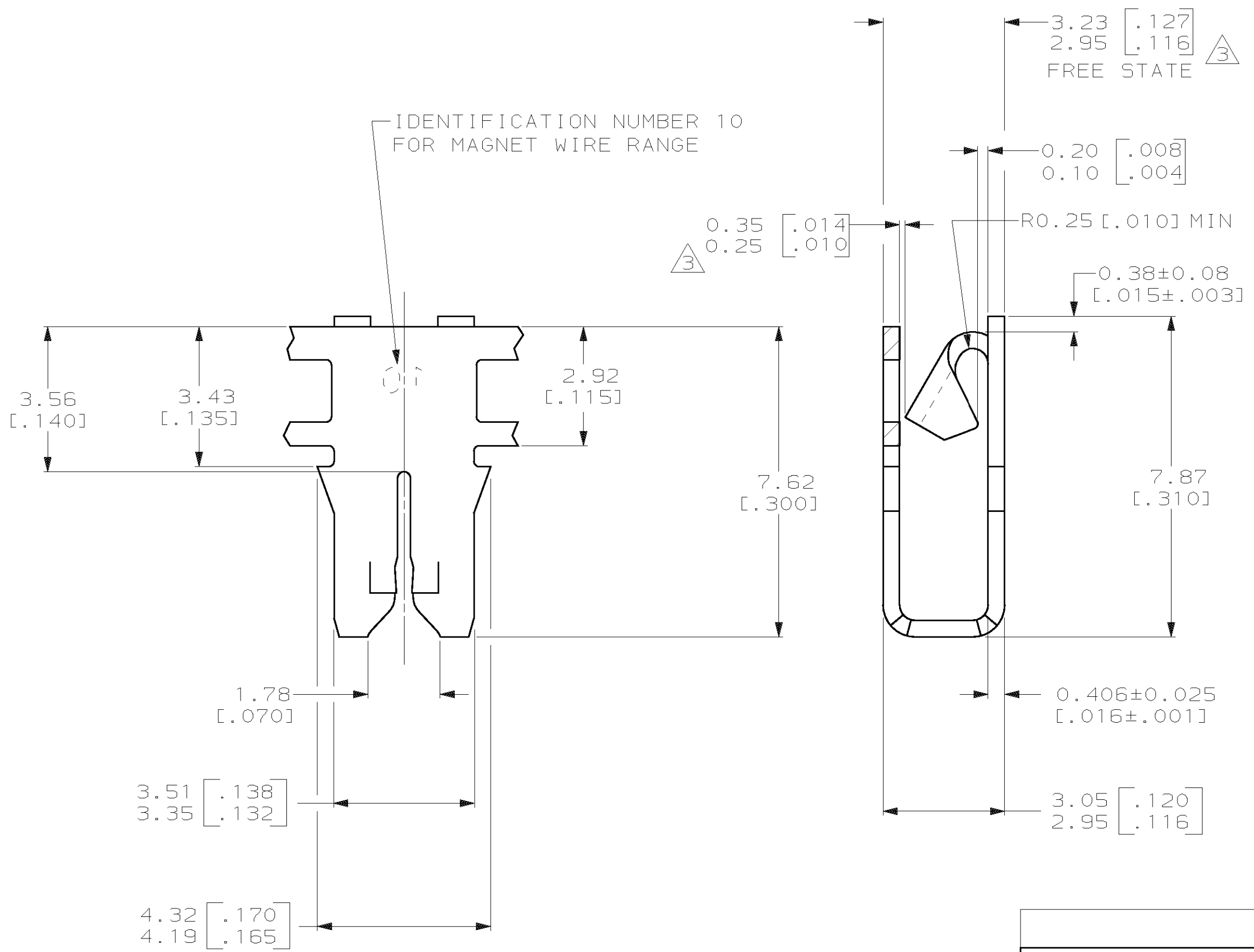

63861-1

PART NO

DO NOT SCALE PRINT. UNLESS SPECIFIED DIMENSIONS IN mm [INCHES] TOLERANCES ON : 2 PLC DEC ± 0.25 [.010] 3 PLC DEC ± - ANGLES ± -	DR 07/JUN/95 MICHAEL S. FEHER	AMP Incorporated Harrisburg, PA 17105-3608		
	CHK 08/JUN/95 JEFF R. RUTH			NAME
MATERIAL UNS C511 H04 PHOS. BRONZE AMP SPEC 100-221	APPD 08/JUN/95 KURT A. RANDOLPH	TERMINAL, POKE-IN, 300 SERIES MAG-MATE™		
FINISH 0.002032 [.000080] MIN TIN PLATE	APPD 08/JUN/95 TERRY L. SHUTTER			
	PRODUCT SPEC 108-2012	SIZE	CAGE CODE	DRAWING NO
	APPLICATION SPEC 114-2046	C	00779	C=63861
	WEIGHT -	SCALE 10:1		SHEET 1 OF 1

THIS DRAWING IS A CONTROLLED DOCUMENT FOR AMP INCORPORATED. IT IS SUBJECT TO CHANGE AND THE CONTROLLING ENGINEERING ORGANIZATION SHOULD BE CONTACTED FOR THE LATEST REVISION.