



Chipsmall Limited consists of a professional team with an average of over 10 year of expertise in the distribution of electronic components. Based in Hongkong, we have already established firm and mutual-benefit business relationships with customers from,Europe,America and south Asia,supplying obsolete and hard-to-find components to meet their specific needs.

With the principle of “Quality Parts,Customers Priority,Honest Operation,and Considerate Service”,our business mainly focus on the distribution of electronic components. Line cards we deal with include Microchip,ALPS,ROHM,Xilinx,Pulse,ON,Everlight and Freescale. Main products comprise IC,Modules,Potentiometer,IC Socket,Relay,Connector.Our parts cover such applications as commercial,industrial, and automotives areas.

We are looking forward to setting up business relationship with you and hope to provide you with the best service and solution. Let us make a better world for our industry!



Contact us

Tel: +86-755-8981 8866 Fax: +86-755-8427 6832

Email & Skype: info@chipsmall.com Web: www.chipsmall.com

Address: A1208, Overseas Decoration Building, #122 Zhenhua RD., Futian, Shenzhen, China



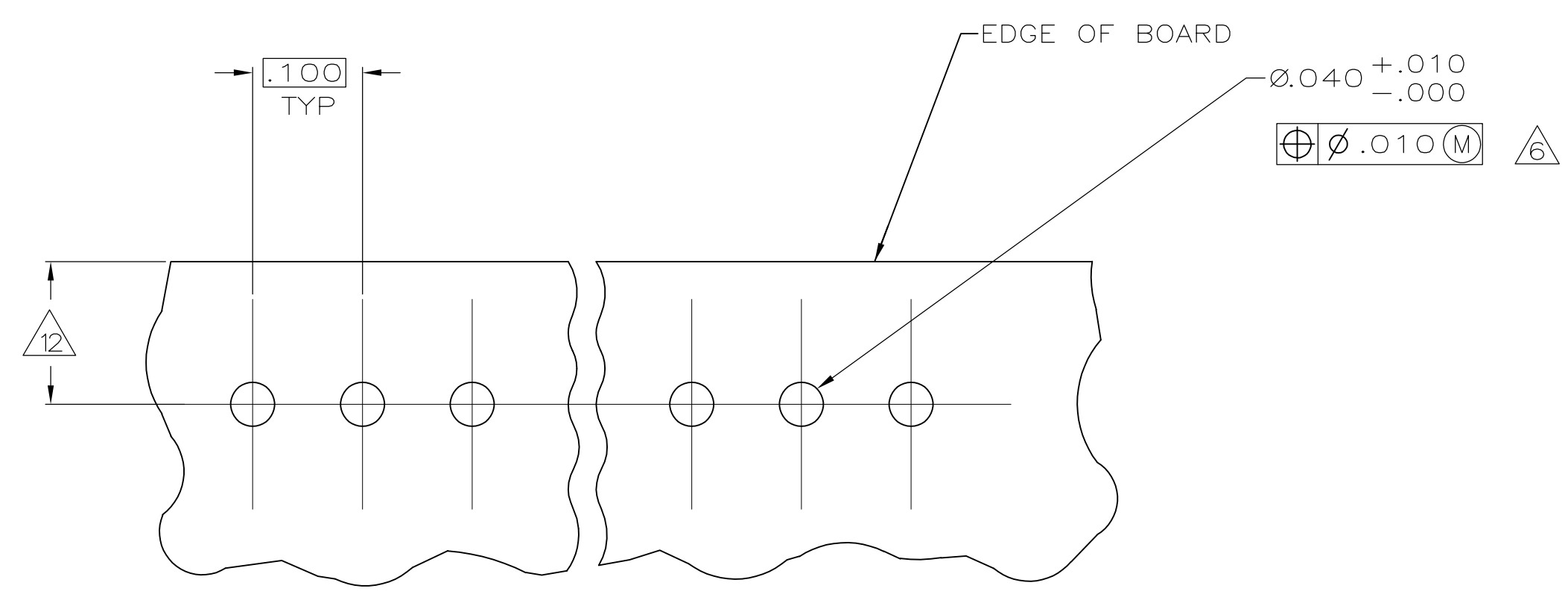
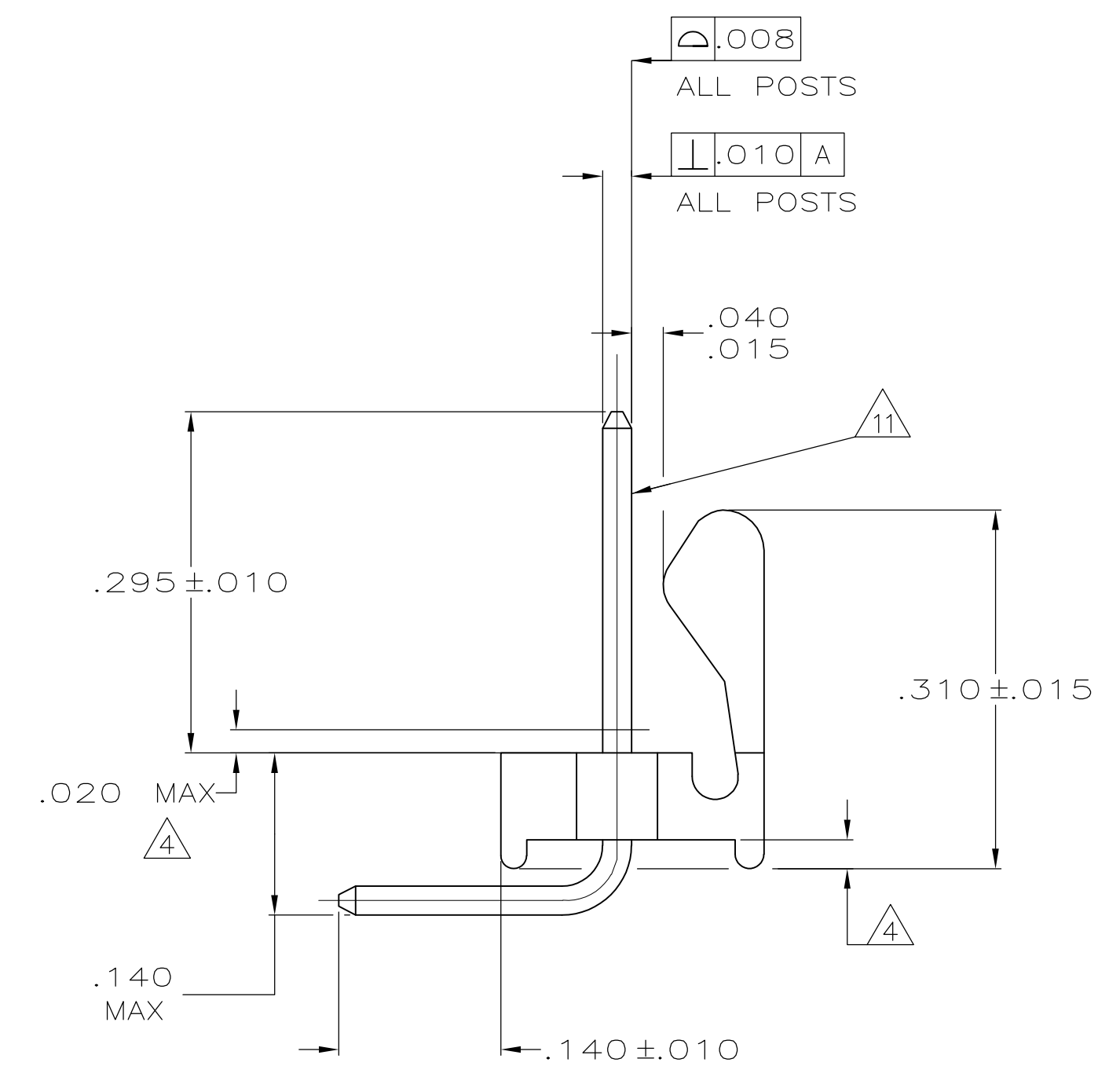
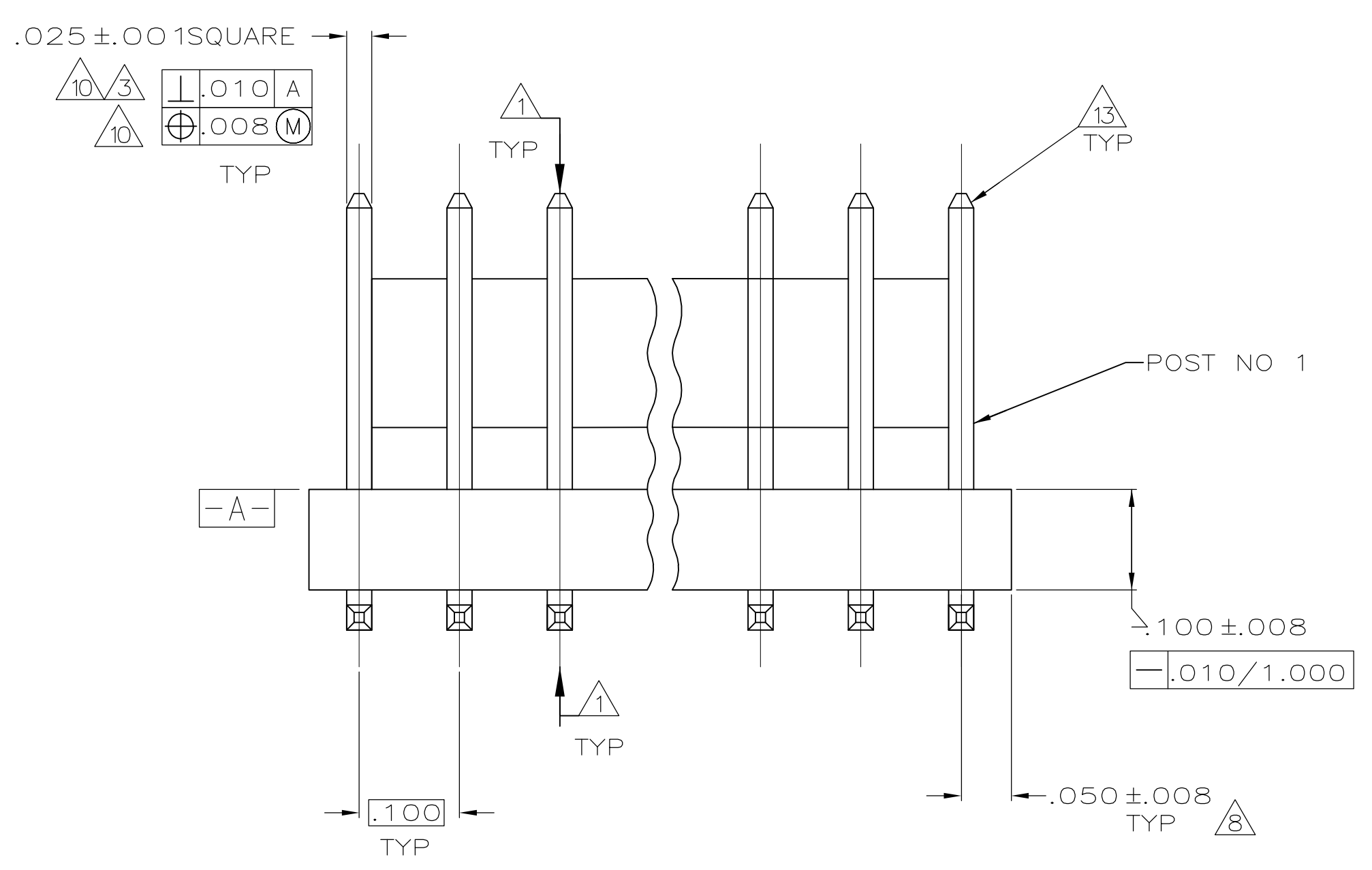
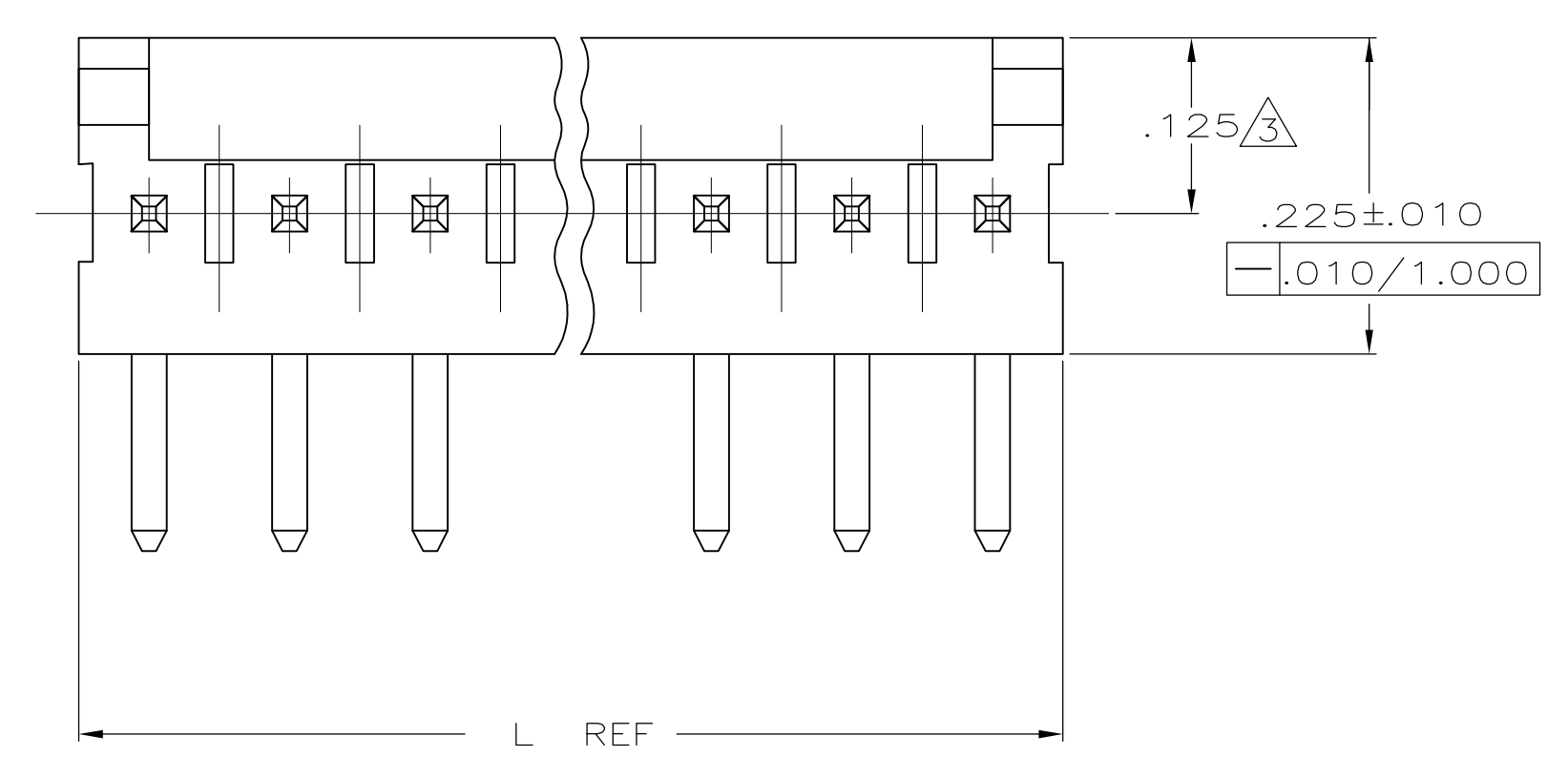

- 1. POST TO WITHSTAND 13 NEWTONS (3LBS.) MIN. AXIAL FORCE IN BOTH DIRECTIONS SHOWN WITHOUT DISLODGING.
- 2. TOLERANCES APPLY TO SOLDER SIDE OF BOARD.
- 3. MEASURED AT SURFACE -A-
- 4. PLASTIC FLASH PERMITTED IN THIS AREA.
- 5. PARTS COMPLY WITH AMP SOLDERABILITY SPEC. NO. 109-11-2.
- 6. ONE HOLE MAY BE UNDERSIZED (.035/.032 DIA.) FOR ASSEMBLY RETENTION DURING WAVE SOLDERING.
- 7. MATERIAL: HEADER-THERMOPLASTIC POLYESTER 94V-0(NATURAL) POST-COPPER ALLOY (TIN PLATED)
- 8. COORDINATE DIMENSION APPLIES FROM CENTER OF ACTUAL FEATURE.
- 9. PLASTIC BURRS CAUSED BY CUT-OFF TOOLING ARE PERMITTED WITHIN THE MAXIMUM TOLERANCE ENVELOPE.
- 10. POST TO BE MEASURED WHEN STRIP IS HELD FLAT.
- 11. POST MUST WITHSTAND TWO 90° BENDS AGAINST EXTRUSION WITHOUT BREAKING.
- 12. DIMENSION SHOULD BE .110-.160 WHEN MATING WITH A MTA 100 CONNECTOR ASSEMBLY OR .110-.120 WHEN MATING WITH A CST 100 CONNECTOR.
- 13. PIN BURR OF .005 MAX. VERTICAL AND .003 MAX. HORIZONTAL PERMITTED AT POST TIPS ON BOTH ENDS.

		1.000	25.40
.040	1.02	.310	7.87
.035	0.89	.295	7.49
.032	0.81	.225	5.72
.025	0.64	.160	4.06
.020	0.51	.140	3.56
.015	0.38	.125	3.18
.010	0.25	.120	3.05
.008	0.20	.110	2.79
.005	0.13	.100	2.54
.003	0.08	.063	1.60
.001	0.03	.050	1.27
IN	MM	IN	MM

CONVERSION TABLE

RECOMMENDED MOUNTING HOLE PATTERN FOR .063 THICK P.C. BOARD

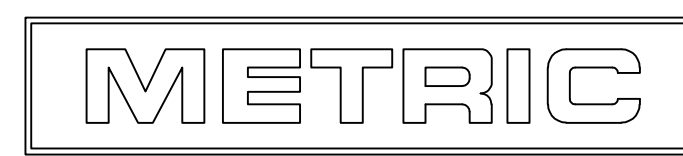

2.800	71.12	28	2-640457-8
2.700	68.58	27	2-640457-7
2.600	66.04	26	2-640457-6
2.500	63.50	25	2-640457-5
2.400	60.96	24	2-640457-4
2.300	58.42	23	2-640457-3
2.200	55.88	22	2-640457-2
2.100	53.34	21	2-640457-1
2.000	50.80	20	2-640457-0
1.900	48.26	19	1-640457-9
1.800	45.72	18	1-640457-8
1.700	43.18	17	1-640457-7
1.600	40.64	16	1-640457-6
1.500	38.10	15	1-640457-5
1.400	35.56	14	1-640457-4
1.300	33.02	13	1-640457-3
1.200	30.48	12	1-640457-2
1.100	27.94	11	1-640457-1
1.000	25.40	10	1-640457-0
.900	22.86	9	640457-9
.800	20.32	8	640457-8
.700	17.78	7	640457-7
.600	15.24	6	640457-6
.500	12.70	5	640457-5
.400	10.16	4	640457-4
.300	7.62	3	640457-3
.200	5.08	2	640457-2
IN	MM	NO OF POSITIONS	PART NUMBER

THIS DRAWING IS A CONTROLLED DOCUMENT.

OWN: B. LEWIS 2-12-93
 CHK: R. SWING 2-12-93
 APVD: R. SPEER 3-11-93

STE TE Connectivity

MTA 100 HEADER ASSEMBLY, FRICTION LOCK, NOTCHED, .025 SQUARE RIGHT ANGLE POST, TIN PLATED

SIZE: A1 CAGE CODE: 00779 DRAWING NO: 640457

SCALE: 8:1 SHEET: 1 OF 1 REV: S1