



Chipsmall Limited consists of a professional team with an average of over 10 year of expertise in the distribution of electronic components. Based in Hongkong, we have already established firm and mutual-benefit business relationships with customers from,Europe,America and south Asia,supplying obsolete and hard-to-find components to meet their specific needs.

With the principle of “Quality Parts,Customers Priority,Honest Operation,and Considerate Service”,our business mainly focus on the distribution of electronic components. Line cards we deal with include Microchip,ALPS,ROHM,Xilinx,Pulse,ON,Everlight and Freescale. Main products comprise IC,Modules,Potentiometer,IC Socket,Relay,Connector.Our parts cover such applications as commercial,industrial, and automotives areas.

We are looking forward to setting up business relationship with you and hope to provide you with the best service and solution. Let us make a better world for our industry!



Contact us

Tel: +86-755-8981 8866 Fax: +86-755-8427 6832

Email & Skype: info@chipsmall.com Web: www.chipsmall.com

Address: A1208, Overseas Decoration Building, #122 Zhenhua RD., Futian, Shenzhen, China



LOC		DIST		REVISIONS			
ES	00	P	LTN	DESCRIPTION	DATE	DWN	APVD
		E8		REV PER ECR-12-021802	04JAN2013	ML	SZ

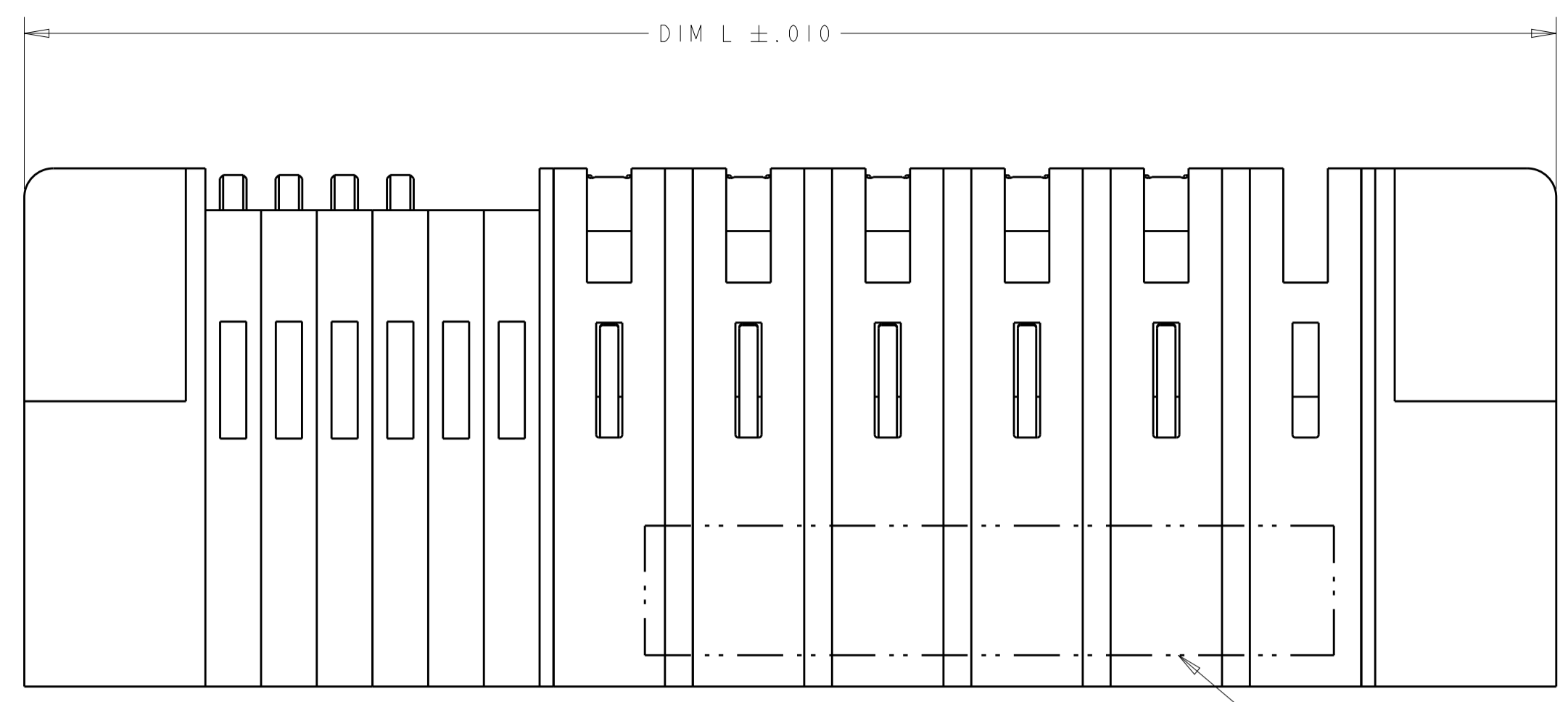

- ⚠ "AMP", PART NUMBER, AND DATE CODE TO BE MARKED IN AREA SHOWN.
- ⚠ MATERIAL: HOUSING - GLASS FILLED HIGH TEMP THERMO PLASTIC, UL94 V-0
 SIGNAL CONTACT - COPPER ALLOY
 POWER CONTACT - HIGH CONDUCTIVITY COPPER ALLOY
- ⚠ CONTACT PLATING: NOBLE METAL PLATING ON CONTACT FUNCTIONAL AREA OF POWER CONTACTS AND SIGNAL CONTACTS.
- ⚠ MECHANICAL CONNECTOR KEEP OUT ZONE.
- ⚠ DATUM AND BASIC DIMENSIONS ESTABLISHED BY CUSTOMER.
- ⚠ PCB - ALL HOLE DIAMETERS ARE FINISHED HOLE SIZES.
- ⚠ PCB - .0453±.0010 DRILLED HOLES PLATED WITH .0003 MIN Sn OVER .001 TO .003 CU PLATING TO ACHIEVE A .040±.003 DIA HOLE

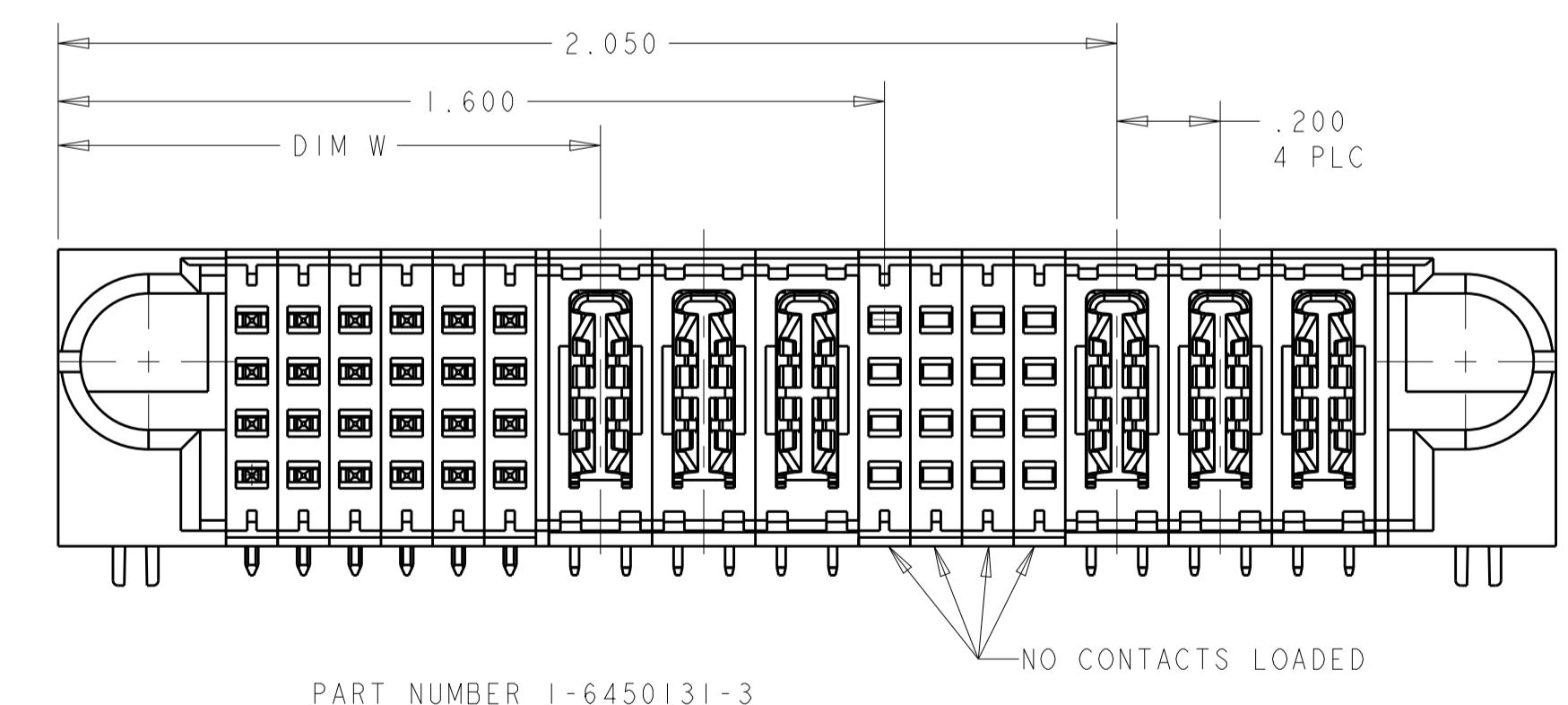
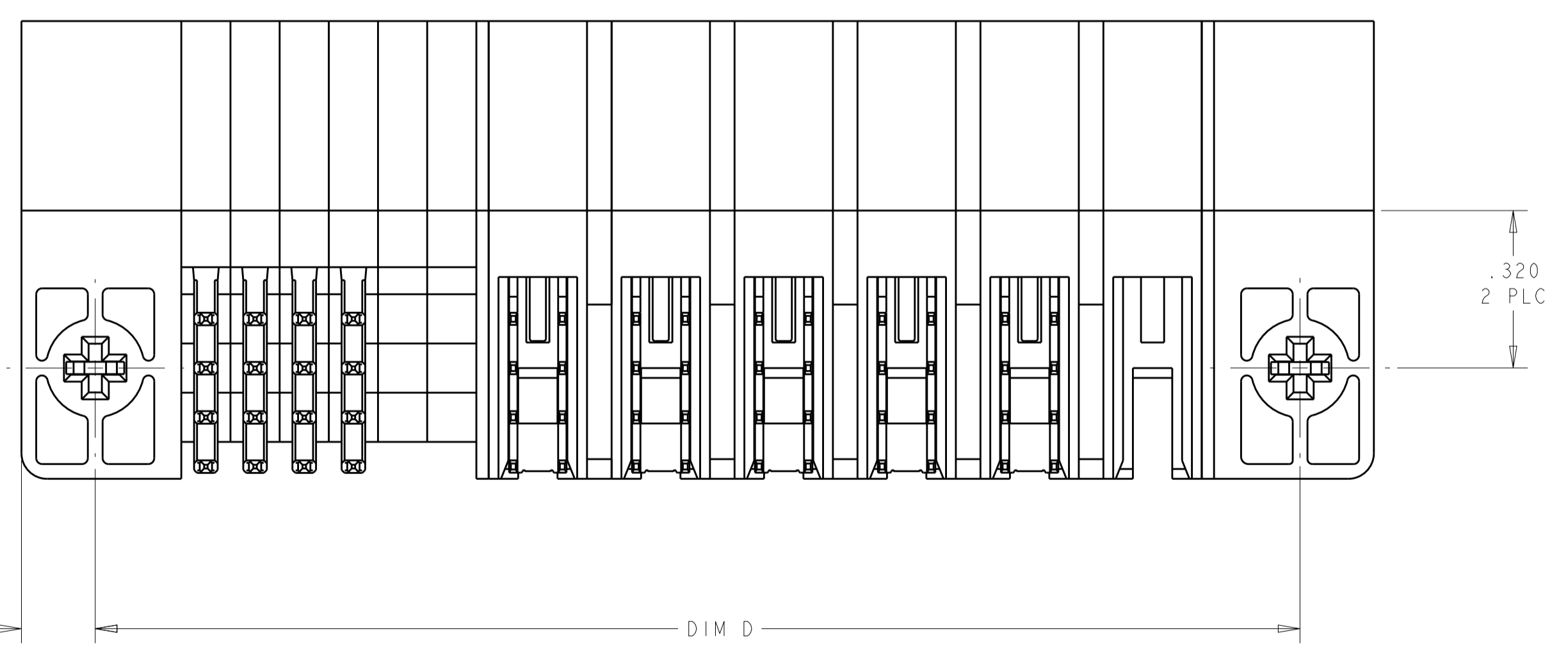
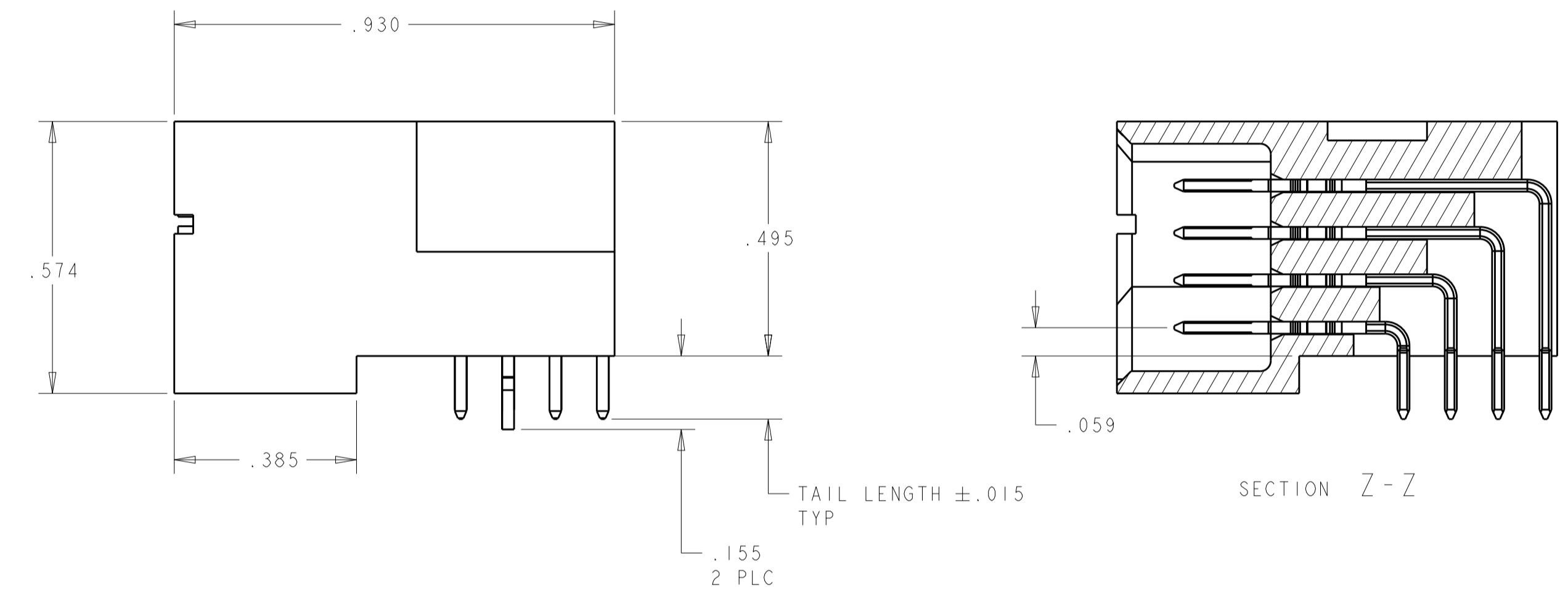
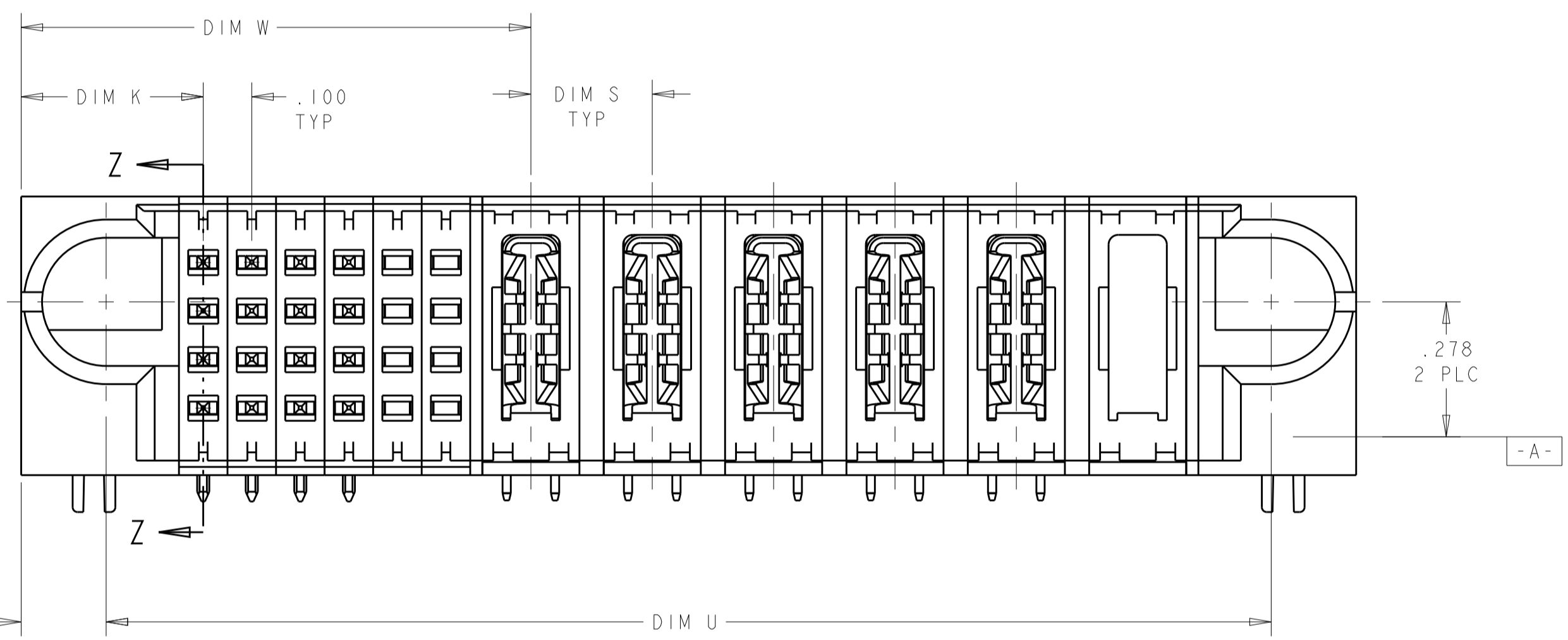

PART NUMBER 1-6450131-3

THIS DRAWING IS A CONTROLLED DOCUMENT.		DWN R. GRZYBOWSKI CHK M. PERCHERKE	15FEB05 15FEB05	TE Connectivity
DIMENSIONS: INCHES 		TOLERANCES UNLESS OTHERWISE SPECIFIED: 0 PLC ±. 1 PLC ±.01 2 PLC ±.005 3 PLC ±.002 4 PLC ±.0020 ANGLES ±.2° FINISH		
MATERIAL		APVD M. PERCHERKE PRODUCT SPEC 108-1973 APPLICATION SPEC 114-13038 WEIGHT CUSTOMER DRAWING		NAME RIGHT ANGLE HEADER ASSY SOLDER CONTACTS, W/GUIDES MULTI-BEAM XL SIZE A100779 CAGE CODE 6450131 SCALE 2:1 SHEET 1 OF 8 REV E8

LOC	DIST	REVISIONS					
		P	LTN	DESCRIPTION	DATE	DMN	APVD
ES	00	-	-	SEE SHEET 1	-	-	-

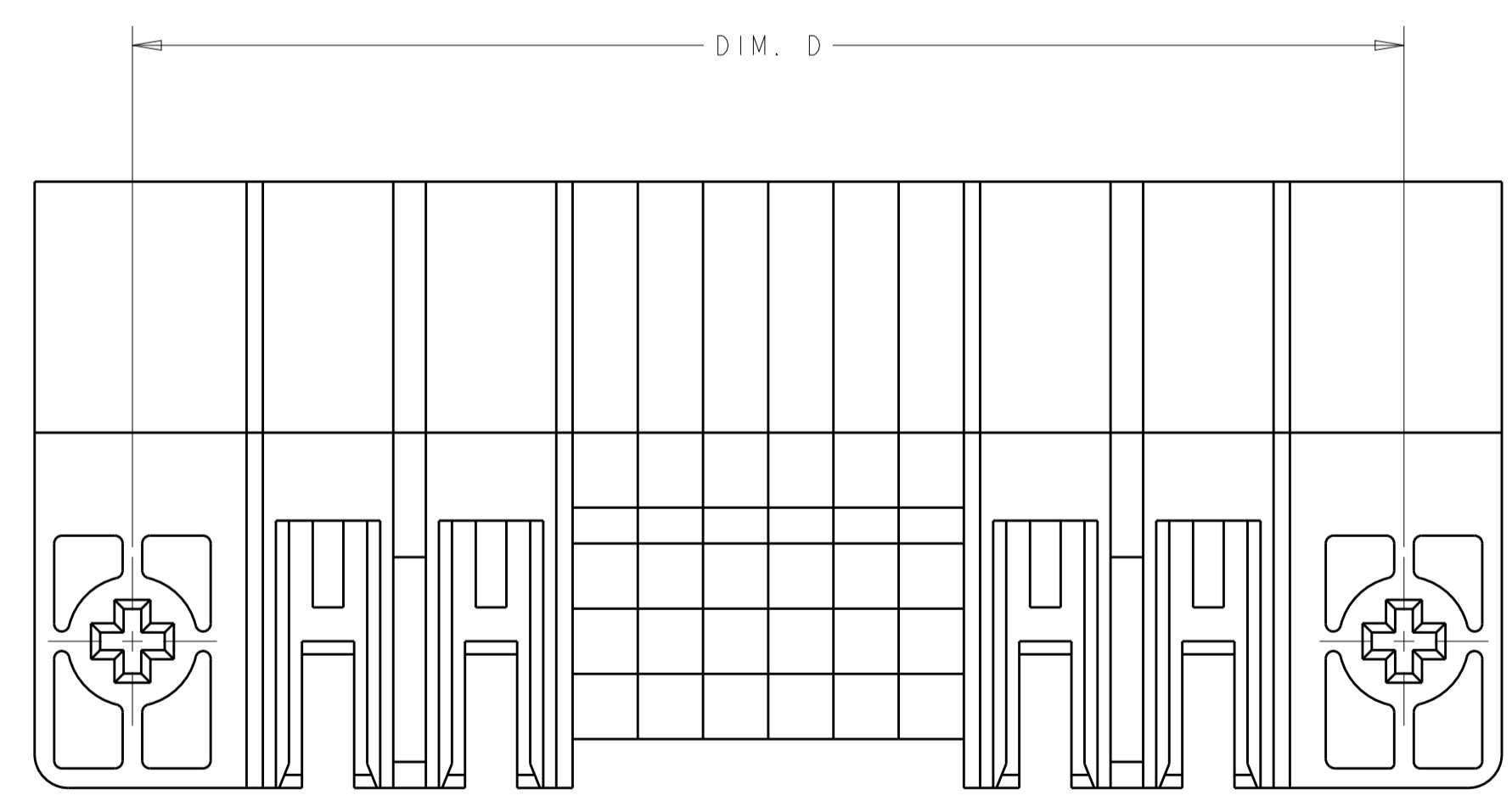
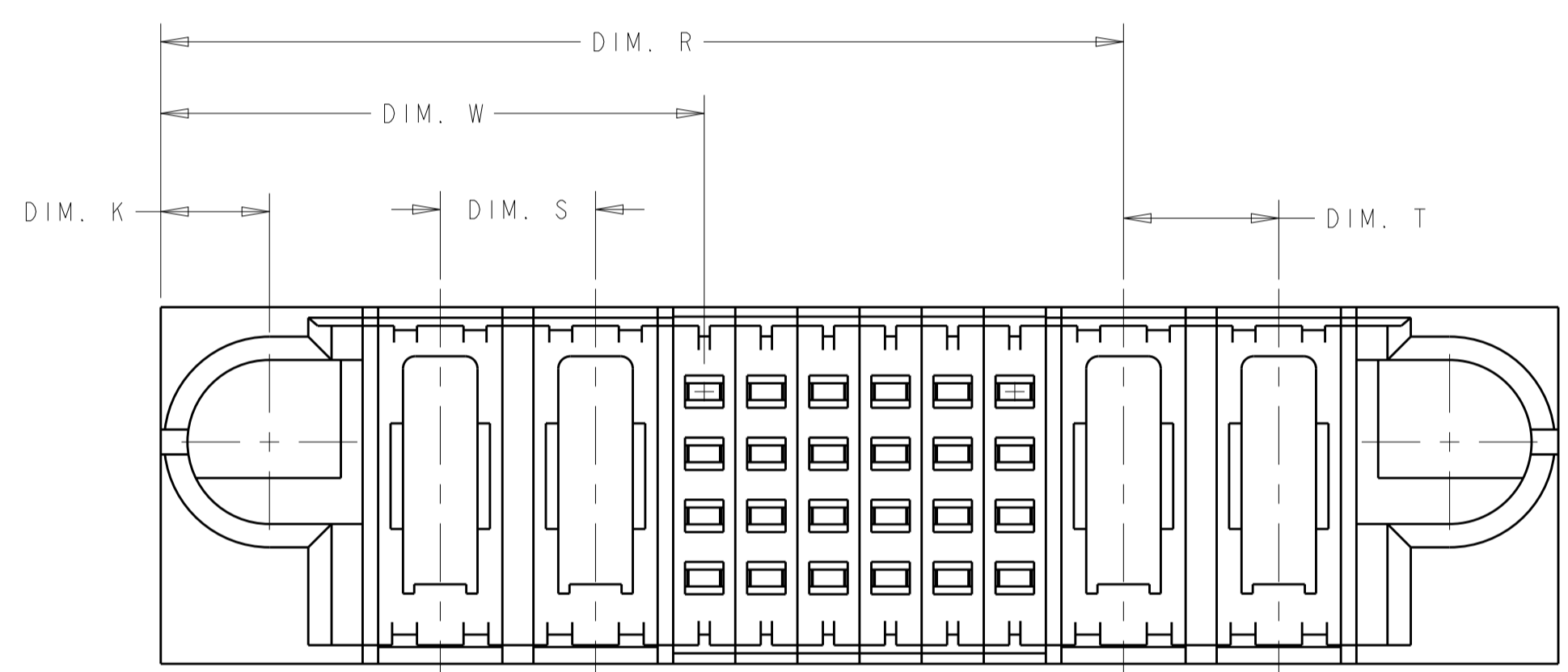
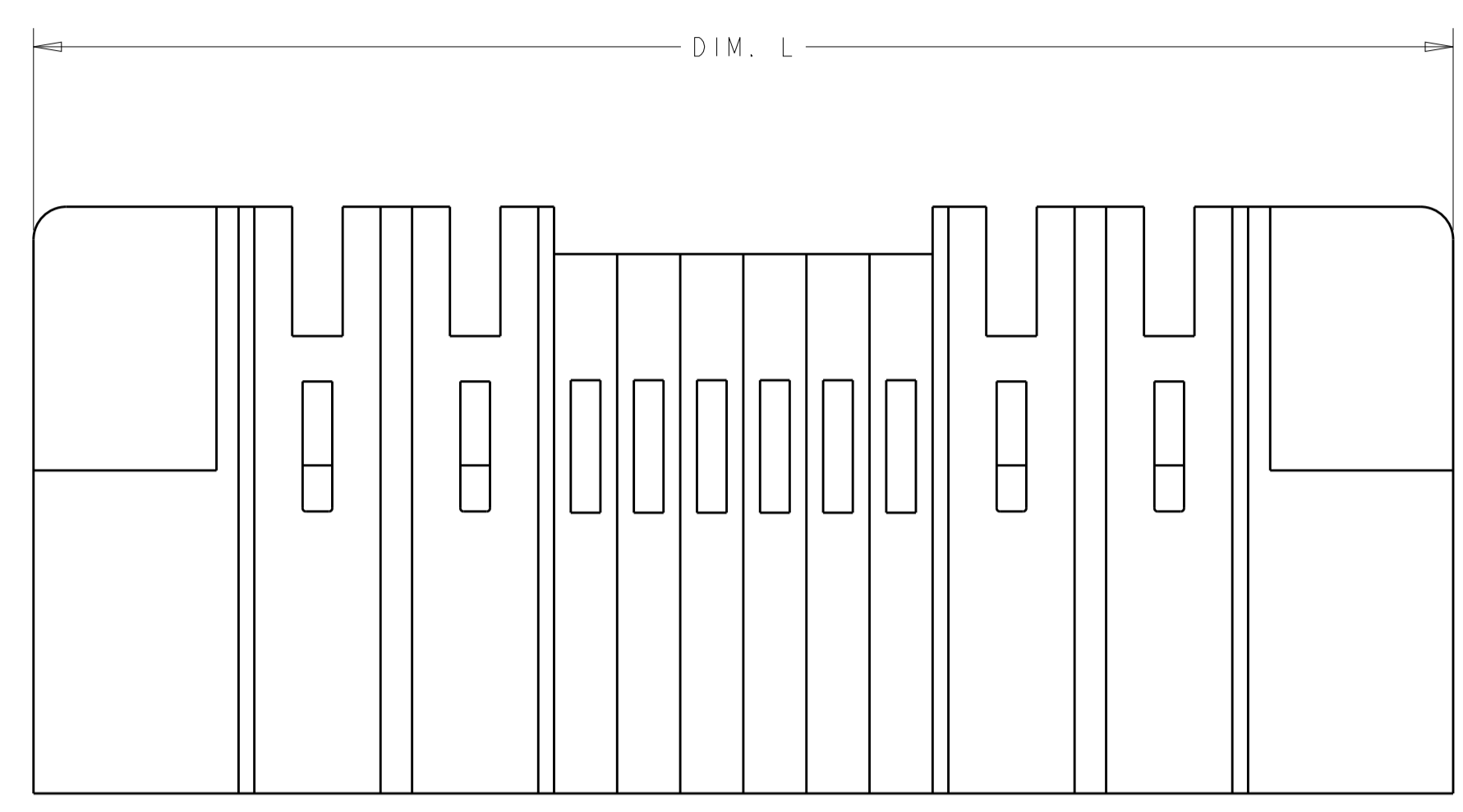

PART 2-6450131-1
(NO CONTACT VIEW)

DIM R	DIM T	DIM U	DIM S	DIM K	DIM D	DIM W	DIM L	DESCRIPTION	PART NUMBER
-	-	1.700	.250	.375	1.750	.850	2.050	16S + 4P	2-6450131-2
1.550	.250	1.900	.250	.450	1.950	.875	2.250	24S	2-6450131-1
		1.600	.250	.375	1.650	.750	1.950	12S + 4P	1-6450131-9
		3.650	.250	.400	3.700	1.300	4.000	32S + 10P	1-6450131-8
		2.950	.200	.375	3.000	1.050	3.300	24S + 10HDP	1-6450131-7
		2.400	.250	.375	2.450	1.050	2.750	24S + 6P	1-6450131-6
		2.450	.200	.375	2.500	.950	2.800	20S + 8P	1-6450131-5
		2.400	.250	.375	2.450	1.050	2.750	24S + 6P	1-6450131-4
		2.550	.200	.375	2.600	1.050	2.900	24S + 3P + 16S + 3P	1-6450131-3
		2.500	.250	.425	2.550	.875	2.850	12S + 7P	1-6450131-1
		2.400	.250	.375	2.450	1.050	2.750	24S + 6P	6450131-7
		2.700	.300	.375	2.750	.775	3.050	12S + 7ACP	6450131-6
		2.400	.250	.375	2.450	1.050	2.750	24S + 6P	6450131-5
		4.400	.250	.375	4.450	1.050	4.750	24S + 14P	6450131-4
		1.950	.250	.375	2.000	.850	2.300	16S + 5P	6450131-3

THIS DRAWING IS A CONTROLLED DOCUMENT. DWN: R. GRZYBOWSKI 15FEB05
 CHK: M. PERCHERKE 15FEB05
 APVD: M. PERCHERKE

TE Connectivity

RIGHT ANGLE HEADER ASSY
 SOLDER CONTACTS, W/GUIDES
 MULTI-BEAM XL

108-1973
 APPLICATION SPEC

114-13038
 WEIGHT

CUSTOMER DRAWING

SCALE 2:1 SHEET 2 OF 8 REV E8

PART NUMBER	ROWS	SIGNAL				POWER				
		1	2	3	4	P1	P2	P3	P4	P5
6450131-3	D	J	J	J	J	PM	PM	PM	PM	PM
	C	K	K	K	K					
	B	N	N	N	N					
	A	S	S	S	H					
16S + 5P		HD								

PART NUMBER	ROWS	SIGNAL						POWER														
		1	2	3	4	5	6	P1	P2	P3	P4	P5	P6	P7	P8	P9	P10	P11	P12	P13	P14	
6450131-4	D	J	J	J	J	J	J	PM	PM	PM	PM	PM	PM	PM	PM	PM	PM	PM	PM	PM	PM	PM
	C	K	K	K	K	K	K															
	B	N	N	N	N	N	N															
	A	S	S	H	H	S	S															
24S + 14P		HD																				

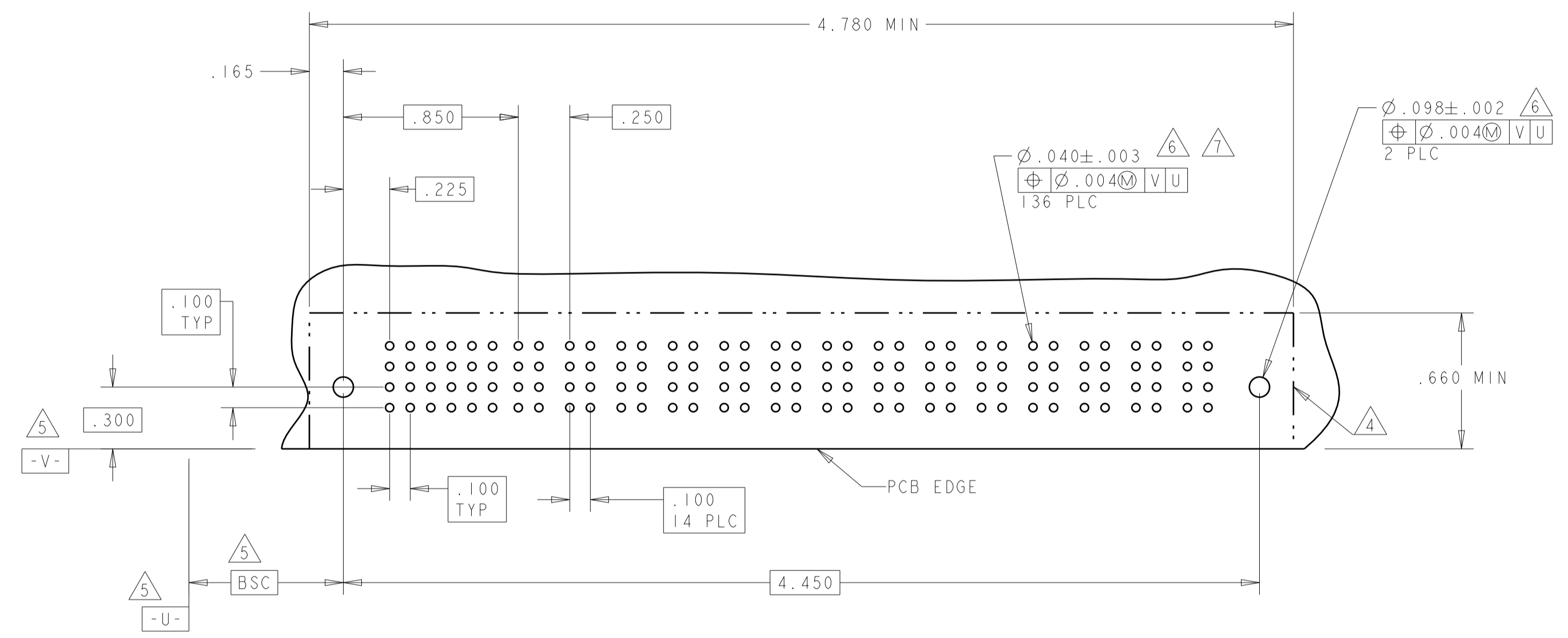
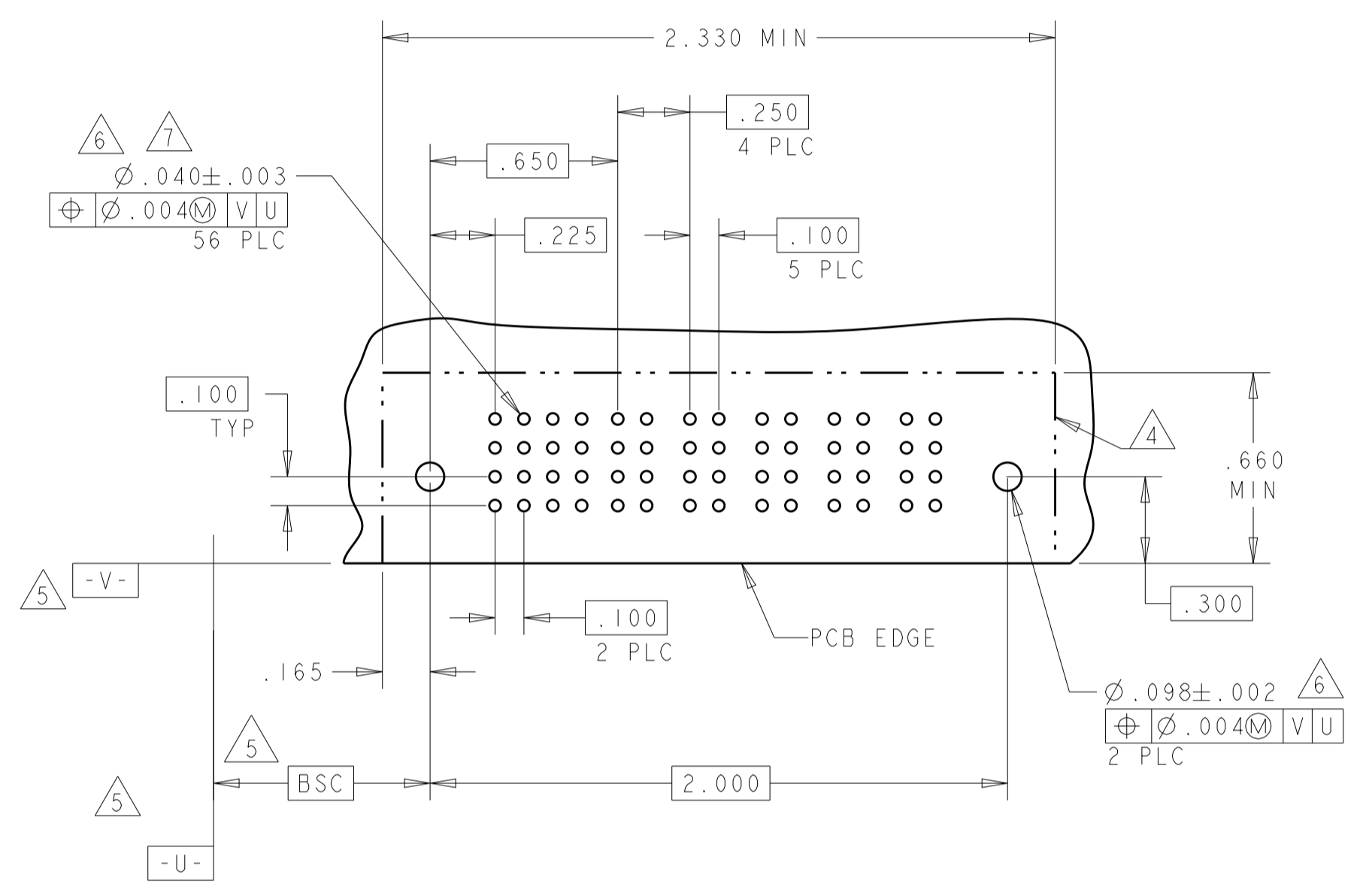

PART NUMBER	ROWS	SIGNAL						POWER					
		1	2	3	4	5	6	P1	P2	P3	P4	P5	P6
6450131-5	D	J	J	J	J	J	E	PM	PM	PM	PM	PM	PM
	C	K	K	K	K	K	K						
	B	N	N	N	N	N	N						
	A	H	S	S	S	S	S						
24S + 6P		HD											

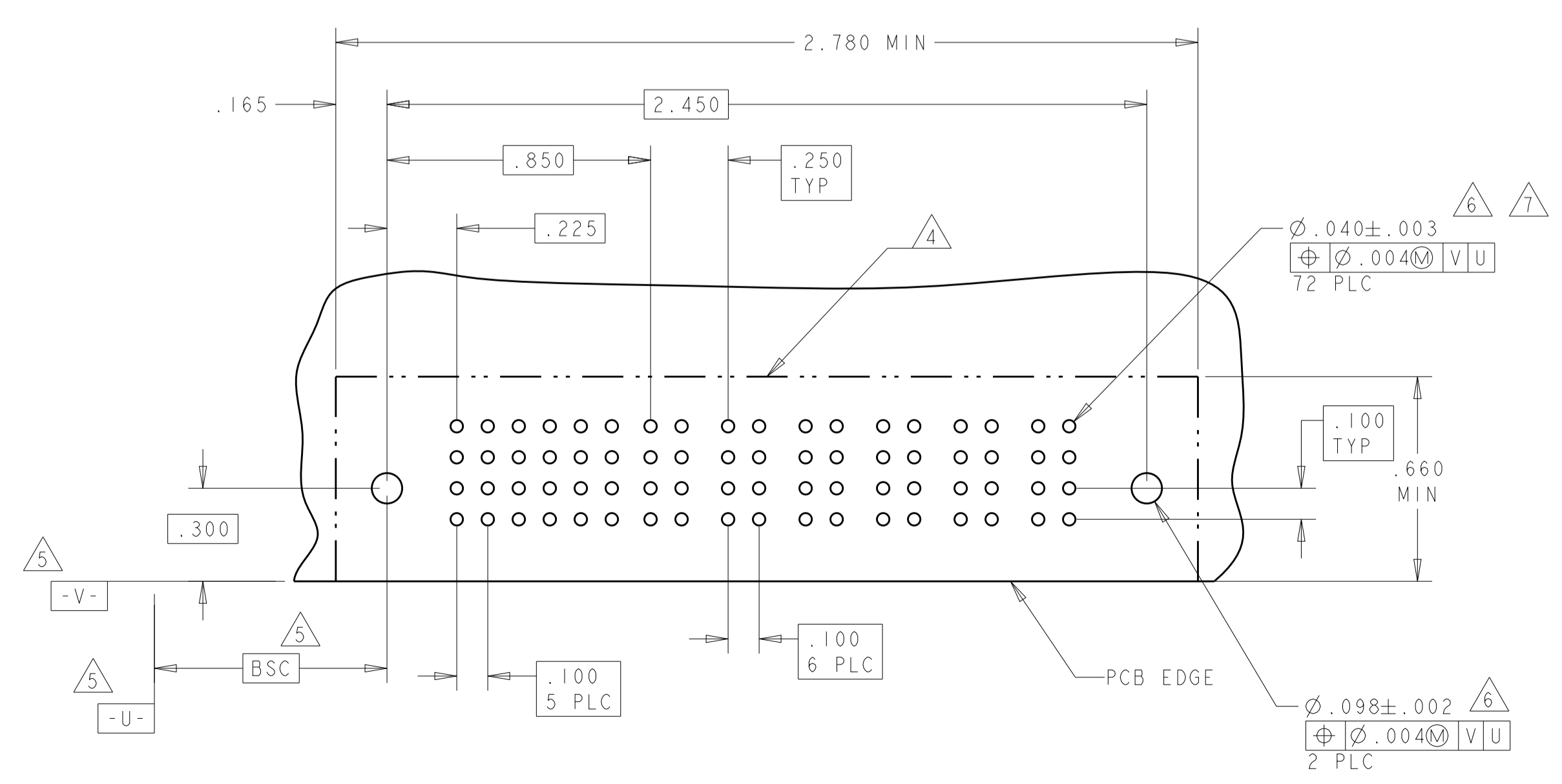

Z	STD	.090	D
Y	STD	.090	C
R	STD	.090	B
O	STD	.090	A
A4	MLBF	.090	D
A3	MLBF	.090	C
A2	MLBF	.090	B
A1	MLBF	.090	A
E	MLBF	.135	D
F	MLBF	.135	C
G	MLBF	.135	B
H	MLBF	.135	A
FJ	MFLB	.135	D
J	STD	.135	D
K	STD	.135	C
N	STD	.135	B
S	STD	.135	A

PA	.090
PM	.135
CODE	TAIL LENGTH
POWER CONTACT	

CODE	MATING SEQUENCE	TAIL LENGTH	ROW
SIGNAL CONTACT			

THIS DRAWING IS A CONTROLLED DOCUMENT.

DIMENSIONS: INCHES	TOLERANCES UNLESS OTHERWISE SPECIFIED:	0 PLC ± .01	1 PLC ± .01	2 PLC ± .01	3 PLC ± .01	4 PLC ± .01	5 PLC ± .01	6 PLC ± .01	7 PLC ± .01	8 PLC ± .01	9 PLC ± .01	10 PLC ± .01	11 PLC ± .01	12 PLC ± .01	13 PLC ± .01	14 PLC ± .01	15 PLC ± .01	16 PLC ± .01	17 PLC ± .01	18 PLC ± .01	19 PLC ± .01	20 PLC ± .01	21 PLC ± .01	22 PLC ± .01	23 PLC ± .01	24 PLC ± .01
--------------------	--	-------------	-------------	-------------	-------------	-------------	-------------	-------------	-------------	-------------	-------------	--------------	--------------	--------------	--------------	--------------	--------------	--------------	--------------	--------------	--------------	--------------	--------------	--------------	--------------	--------------

APVD: M. PERCHERKE

NAME: RIGHT ANGLE HEADER ASSY SOLDER CONTACTS, W/GUIDES MULTI-BEAM XL

PRODUCT SPEC: 108-1973

APPLICATION SPEC: 114-13038

SIZE: A1

CAGE CODE: 6450131

DRAWING NO: 100779

SCALE: 2:1

SHEET: 3 OF 8

REV: E8

PART NUMBER	ROWS	SIGNAL			POWER						
		1	2	3	P1	P2	P3	P4	P5	P6	P7
6450131-6	D	Z	Z	Z	PA	PA	PA	PA	PA	PA	PA
	C	Y	Y	Y							
	B	R	R	R							
	A	AI	O	O							

PART NUMBER	ROWS	SIGNAL			POWER						
		1	2	3	P1	P2	P3	P4	P5	P6	P7
1-6450131-1	D	J	J	J	PM	PM	PM	PM	PM	PM	PM
	C	K	K	K							
	B	N	N	N							
	A	S	S	S							

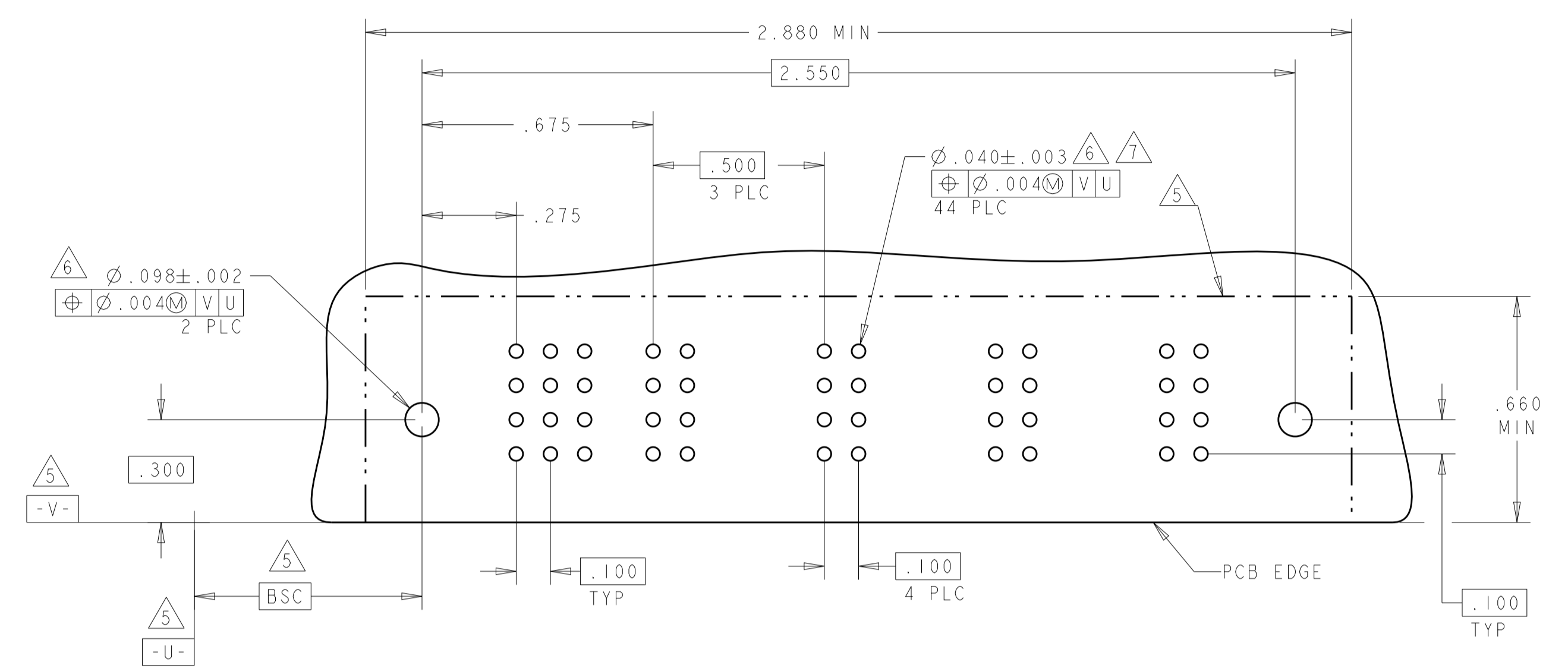
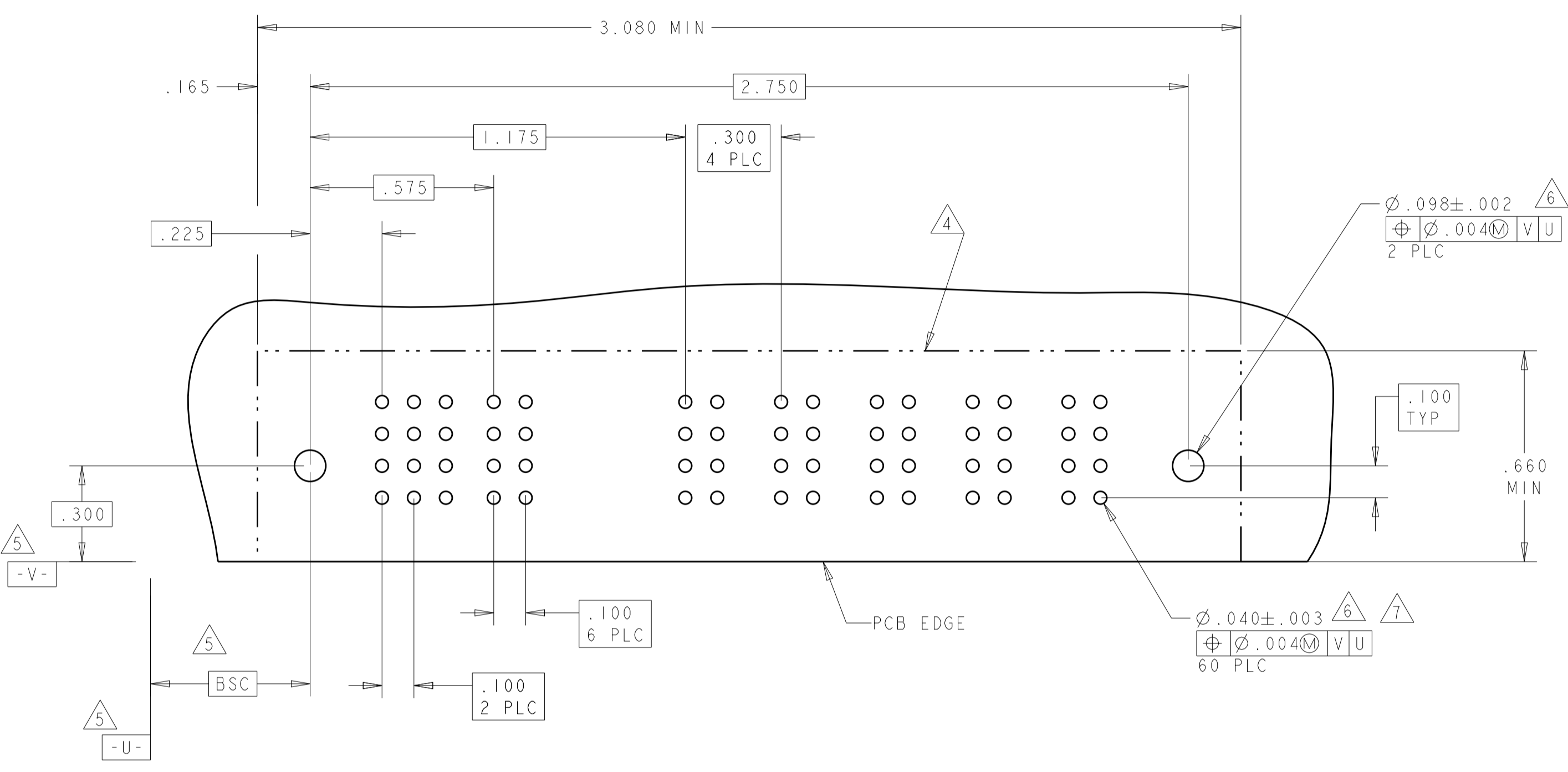

PART NUMBER	ROWS	SIGNAL						POWER					
		1	2	3	4	5	6	P1	P2	P3	P4	P5	P6
6450131-7	D	E	E	J	J	J	E	PM	PM	PM	PM	PM	PM
	C	F	F	K	K	K	K						
	B	G	G	N	N	N	N						
	A	H	H	S	S	S	S						

PART NUMBER	ROWS	SIGNAL						POWER			SIGNAL				POWER		
		1	2	3	4	5	6	P1	P2	P3	7	8	9	10	P4	P5	P6
1-6450131-3	D	J	J	J	J	J	E	PM	PM	PM					PM	PM	PM
	C	K	K	K	K	K	K										
	B	N	N	N	N	N	N										
	A	H	S	S	S	S	S										

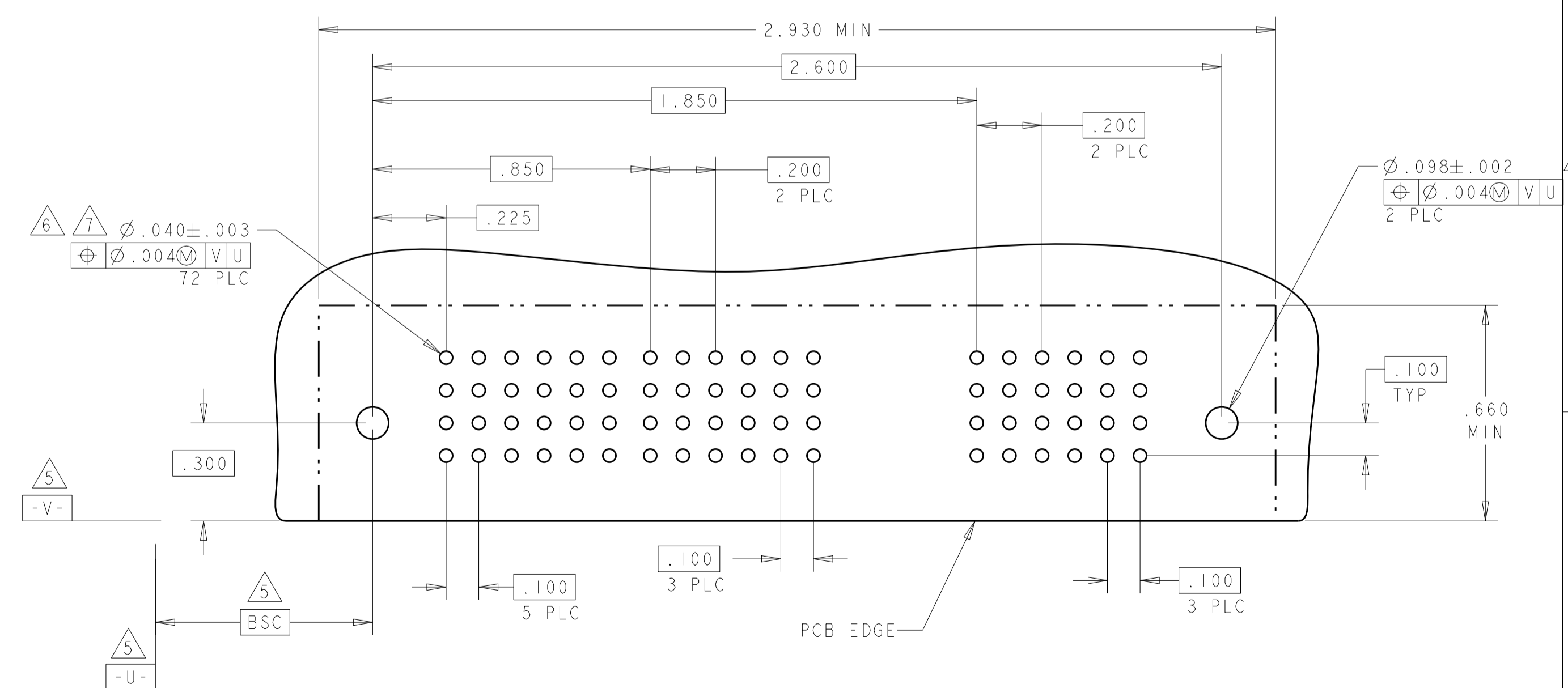
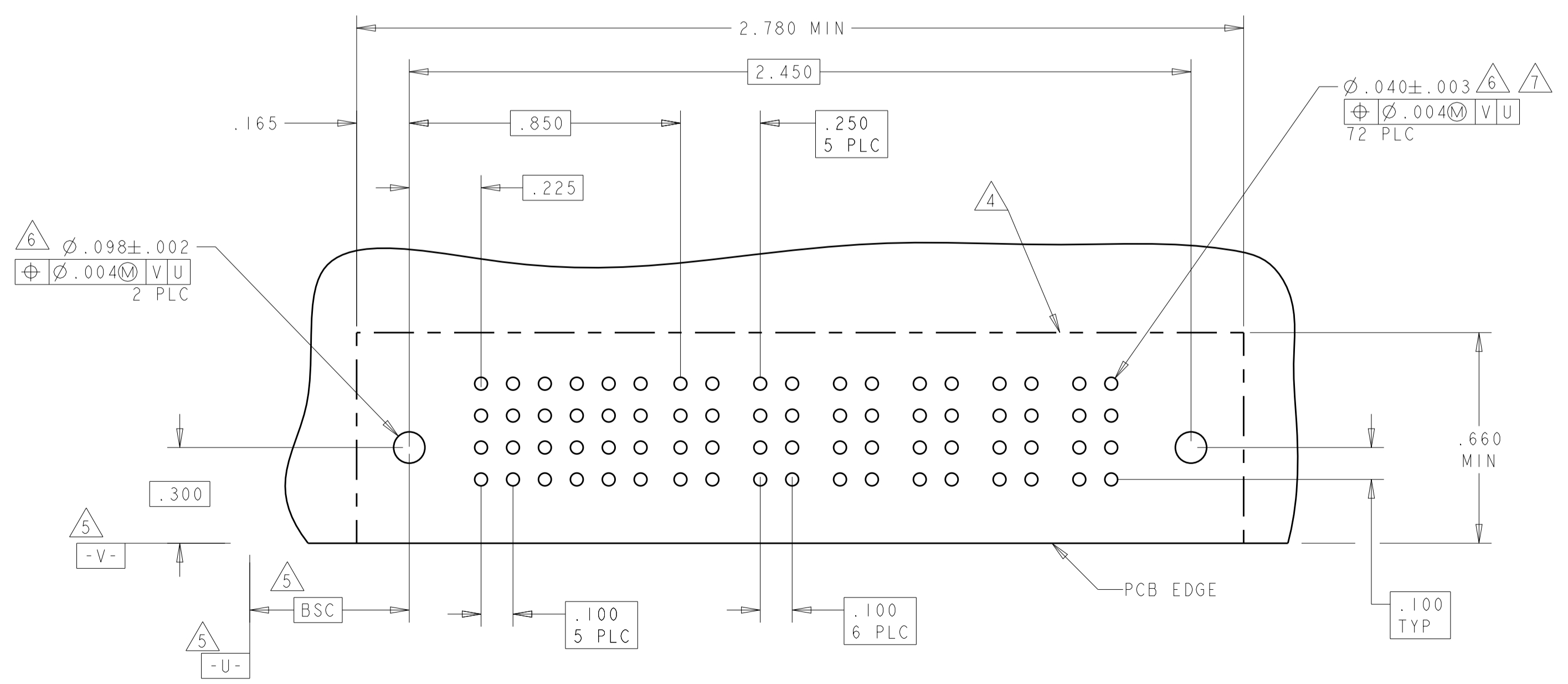

THIS DRAWING IS A CONTROLLED DOCUMENT.		DWN: R. GRZYBOWSKI 15FEB05		TE Connectivity
DIMENSIONS: INCHES		CHK: M. PERCHERKE 15FEB05		RIGHT ANGLE HEADER ASSY SOLDER CONTACTS, W/GUIDES MULTI-BEAM XL
TOLERANCES UNLESS OTHERWISE SPECIFIED:		APVD: M. PERCHERKE	NAME	
0 PLC ±.01		PRODUCT SPEC	108-1973	
1 PLC ±.01		APPLICATION SPEC	114-13038	
2 PLC ±.01		WEIGHT	A100779C=6450131	
3 PLC ±.01		CUSTOMER DRAWING	SCALE 2:1 SHEET 4 OF 8 REV E8	
4 PLC ±.002				
ANGLES				
FINISH				

LOC		DIST		REVISIONS			
ES	00	P	LTN	DESCRIPTION	DATE	OWN	APVD
				SEE SHEET 1			

PART NUMBER	ROWS	SIGNAL						POWER							
		1	2	3	4	5	6	P1	P2	P3	P4	P5	P6		
1-6450131-4	D	J	J	J	J	J	J	PM	PM	PM	PM	PM	PM		
	C	K	K	K	K	K	K								
	B	N	N	N	G	N	N								
	A	S	S	S	H	S	S								
24S + 6P		HD												HD	

PART NUMBER	ROWS	SIGNAL					POWER								
		1	2	3	4	5	P1	P2	P3	P4	P5	P6	P7	P8	
1-6450131-5	D	J	J	J	J	J	PM	PM	PM	PM	PM	PM	PM	PM	
	C	K	K	K	K	K									
	B	N	G	N	N	N									
	A	S	S	S	S	S									
20S + 8P		HD												HD	

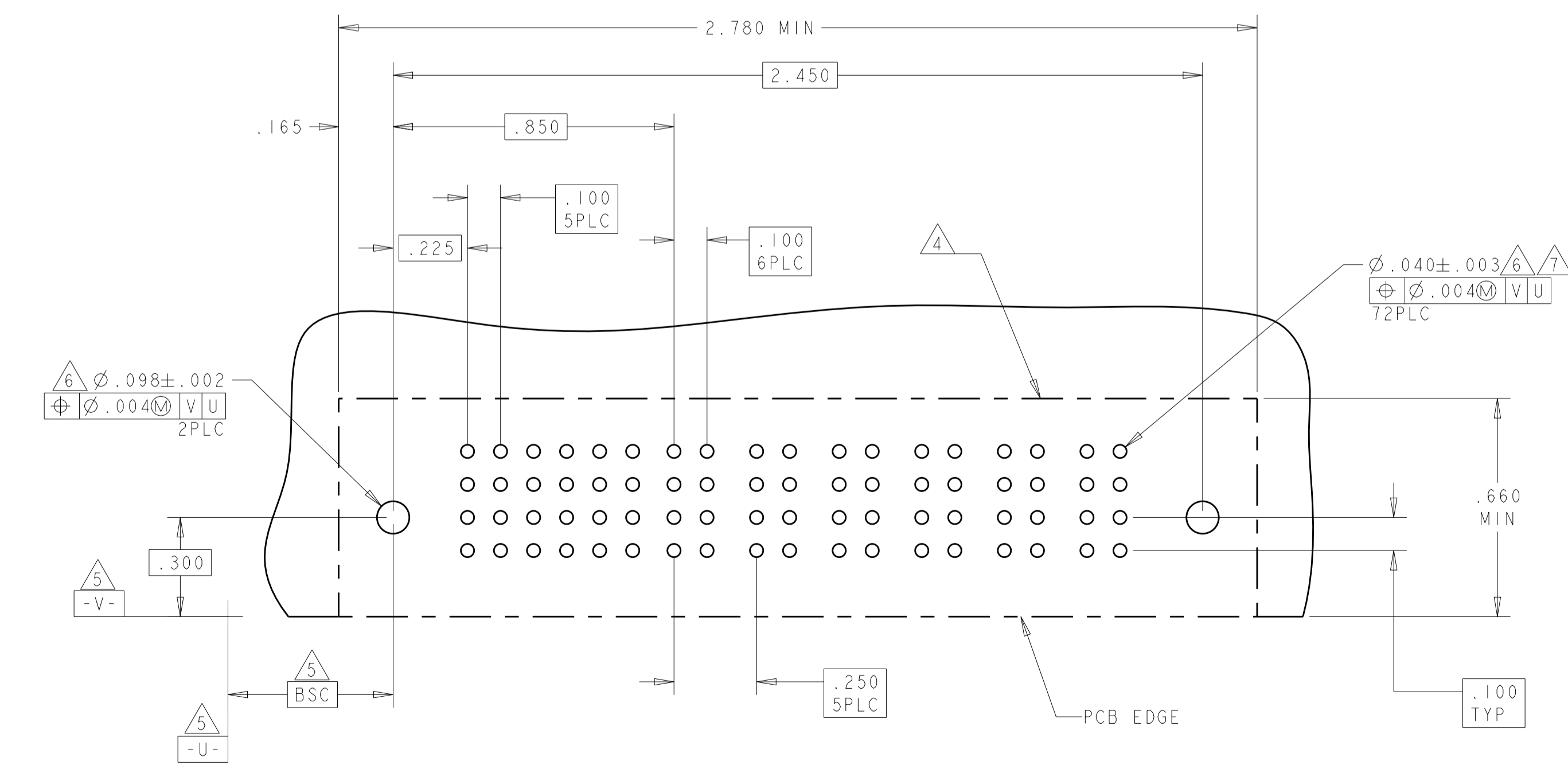
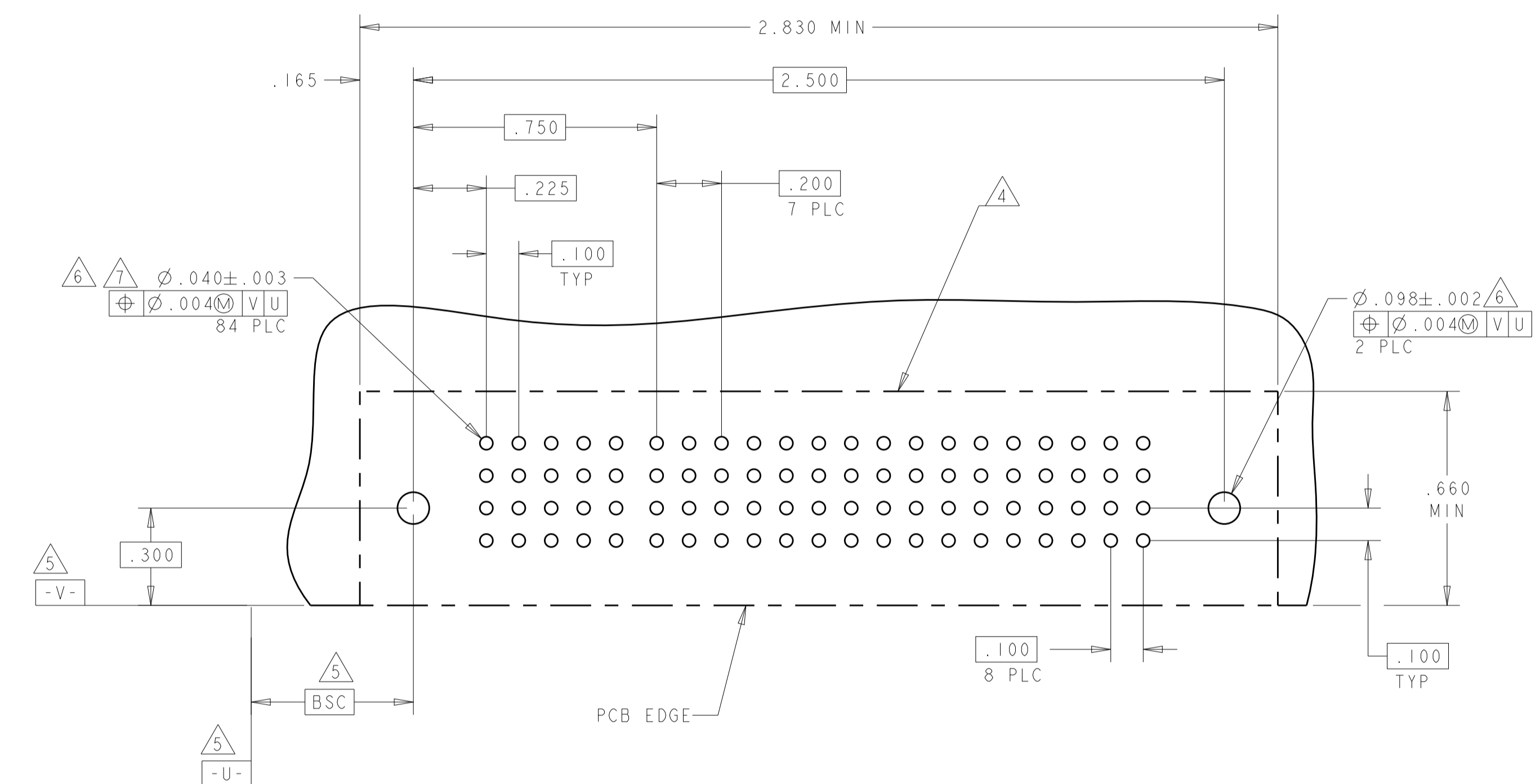
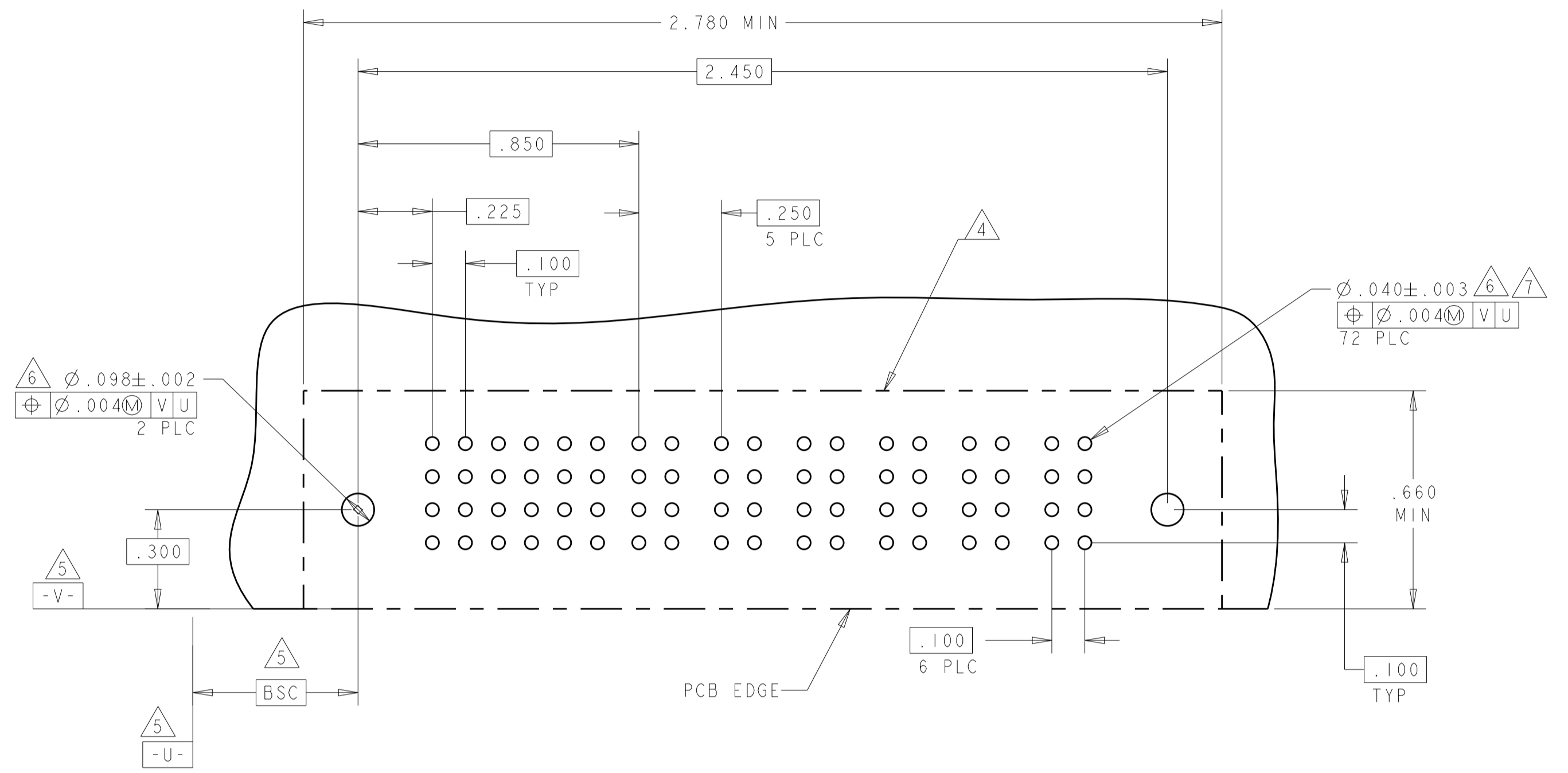

PART NUMBER	ROWS	SIGNAL						POWER							
		1	2	3	4	5	6	P1	P2	P3	P4	P5	P6		
1-6450131-6	D	J	J	J	J	J	E	PM	PM	PM	PM	PM	PM		
	C	K	K	K	K	K	K								
	B	N	N	N	N	N	N								
	A	H	S	S	S	S	S								
24S + 6P		HD												HD	

THIS DRAWING IS A CONTROLLED DOCUMENT. **STE** TE Connectivity

DIMENSIONS: INCHES	TOLERANCES UNLESS OTHERWISE SPECIFIED:	OWN: R. GRZYBOWSKI 15FEB05	CHK: M. PERCHERKE 15FEB05
0 PLC ± .010	1 PLC ± .005	APVD: M. PERCHERKE	NAME: M. PERCHERKE
2 PLC ± .005	3 PLC ± .002	PRODUCT SPEC: 108-1973	APPLICATION SPEC: 114-13038
4 PLC ± .002	ANGLES ± .002	WEIGHT: -	SIZE: 114-13038
MATERIAL: -	FINISH: -	CUSTOMER DRAWING	SCALE: 2:1

RIGHT ANGLE HEADER ASSY
 SOLDER CONTACTS, W/GUIDES
 MULTI-BEAM XL

RESTRICTED TO: A100779 ©=6450131 SHEET 5 OF 8 REV E8

LOC	DIST	REVISIONS			
P	LTN	DESCRIPTION	DATE	DMN	APVD
-	-	SEE SHEET 1	-	-	-

PART NUMBER	ROWS	SIGNAL						POWER									
		1	2	3	4	5	6	P1	P2	P3	P4	P5	P6	P7	P8	P9	P10
1-6450131-7	D	J	J	J	J	J	J	PM	PM	PM	PM	PM	PM	PM	PM	PM	PM
	C	K	K	K	F	K	K	PM	PM	PM	PM	PM	PM	PM	PM	PM	PM
	B	N	N	N	N	N	N	PM	PM	PM	PM	PM	PM	PM	PM	PM	PM
A	A	S	S	S	S	S	S	PM	PM	PM	PM	PM	PM	PM	PM	PM	PM
24S + 10HDP																	

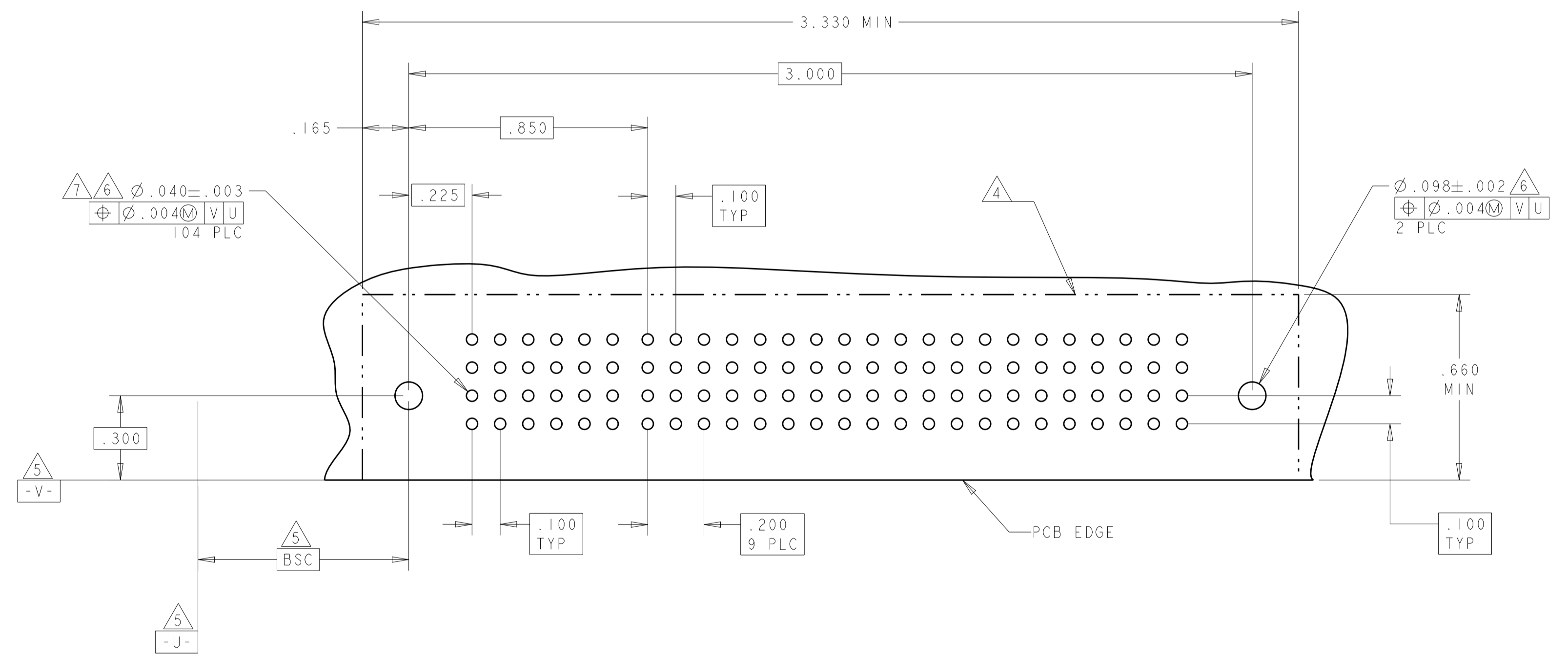

THIS DRAWING IS A CONTROLLED DOCUMENT.

DMN: R. GRZYBOWSKI	15FEB05	STE TE Connectivity
CHK: M. PERCHERKE	15FEB05	
APVD: M. PERCHERKE		NAME: RIGHT ANGLE HEADER ASSY
		PRODUCT SPEC: 108-1973
		APPLICATION SPEC: 114-13038
		SIZE: A1
		CAGE CODE: 6450131
		RESTRICTED TO:
CUSTOMER DRAWING		SCALE: 2:1 SHEET 6 OF 8 REV: E8

LOC	DIST	REVISIONS			
P	LTN	DESCRIPTION	DATE	DMN	APVD
-	-	SEE SHEET 1	-	-	-

PART NUMBER	ROWS	SIGNAL								POWER									
		1	2	3	4	5	6	7	8	P1	P2	P3	P4	P5	P6	P7	P8	P9	P10
I-6450131-8	D	J	J	J	J	J	J	J	J	PM	PM	PM	PM	PM	PM	PM	PM	PM	PM
	C	K	K	K	F	F	K	K	K										
	B	N	N	N	G	G	N	N	N										
32S + 10P	A	S	S	S	S	S	S	S											

PART NUMBER	ROWS	SIGNAL			POWER			
		1	2	3	P1	P2	P3	P4
I-6450131-9	D	J	FJ	FJ				
	C	K	K	K	PM	PM	PM	PM
	B	N	N	N				
12S + 4P	A	H	H	S				

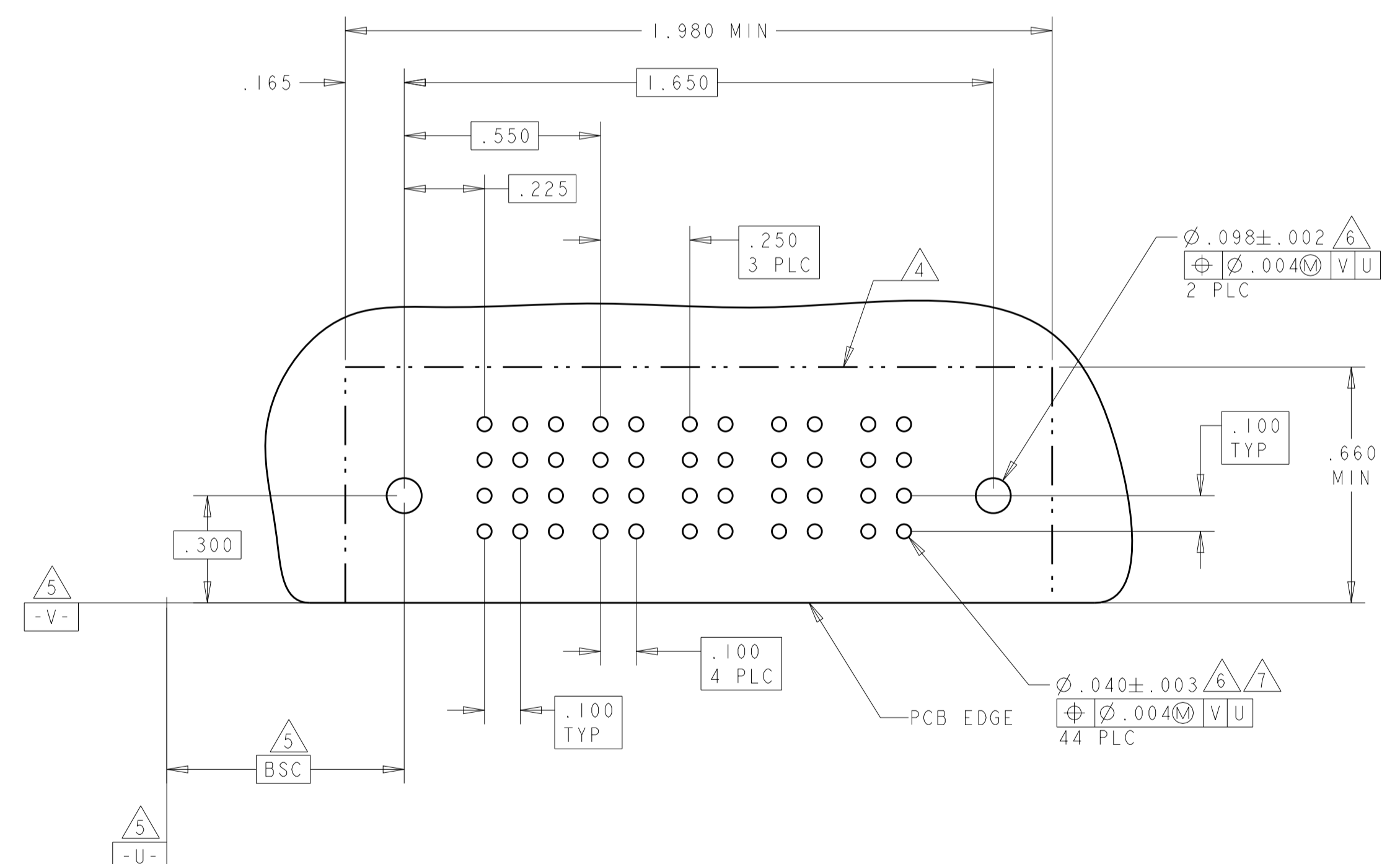
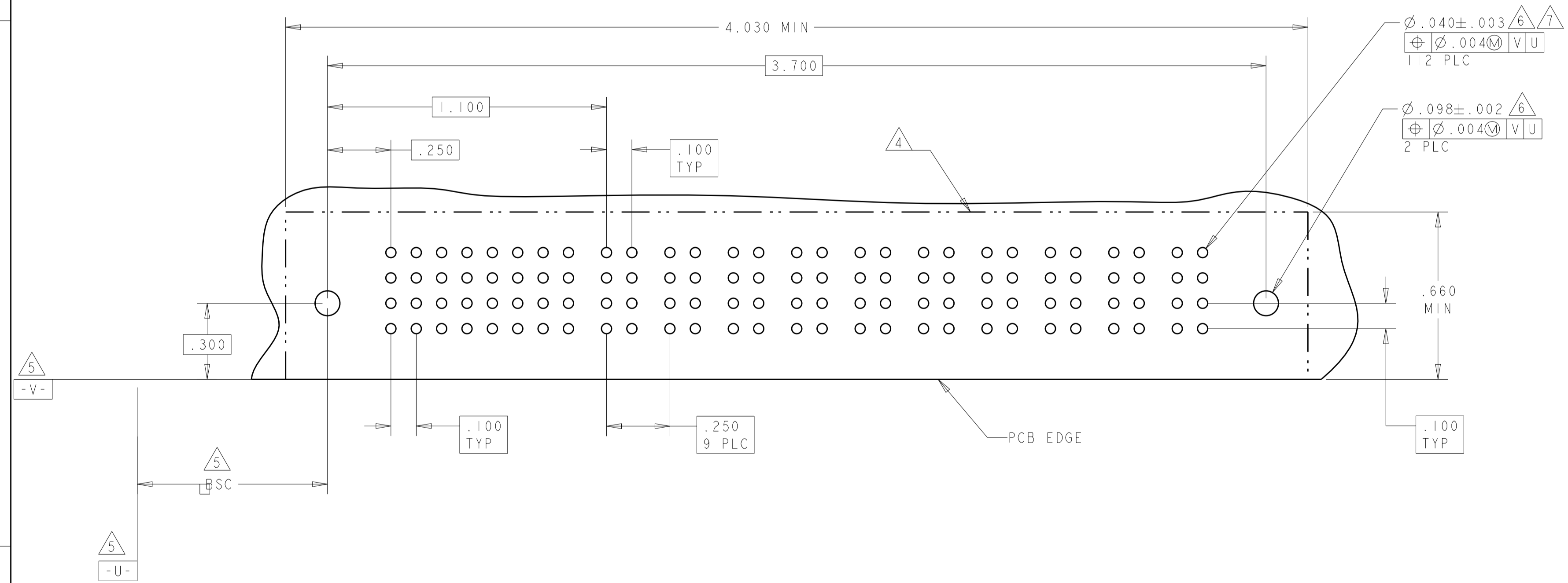

THIS DRAWING IS A CONTROLLED DOCUMENT.

DIMENSIONS: INCHES	TOLERANCES UNLESS OTHERWISE SPECIFIED: 0 PLC ±. 2 PLC ±.01 3 PLC ±.005 4 PLC ±.0020 ANGLES ±.2°	FINISH	APVD: M. PERCHERKE	NAME: M. PERCHERKE	DATE: 108-1973	APPLICATION SPEC: 114-13038	WEIGHT: -	CAGE CODE: A100779	DRAWING NO: C=6450131	RESTRICTED TO: -
-----------------------	--	--------	--------------------	--------------------	----------------	-----------------------------	-----------	--------------------	-----------------------	------------------

OWN: R. GRZYBOWSKI 15FEB05
 CHK: M. PERCHERKE 15FEB05

STE TE Connectivity

RIGHT ANGLE HEADER ASSY
 SOLDER CONTACTS, W/GUIDES
 MULTI-BEAM XL

CUSTOMER DRAWING SCALE: 2:1 SHEET 7 OF 8 REV: E8

LOC	DIST	REV	DATE	BY	APPV
ES	00				

REVISIONS		DATE	BY	APPV
1	SEE SHEET 1			

PART NUMBER	ROWS	POWER		SIGNAL						POWER		
		P1	P2	1	2	3	4	5	6	P3	P4	
2-6450131-1	D	HD		J	J	J	J	J	J			HD
	C			K	K	K	K	K	F			
	B			N	N	N	N	N	N			
	A			S	S	S	S	S	S			

24S

NO CONTACT LOADED

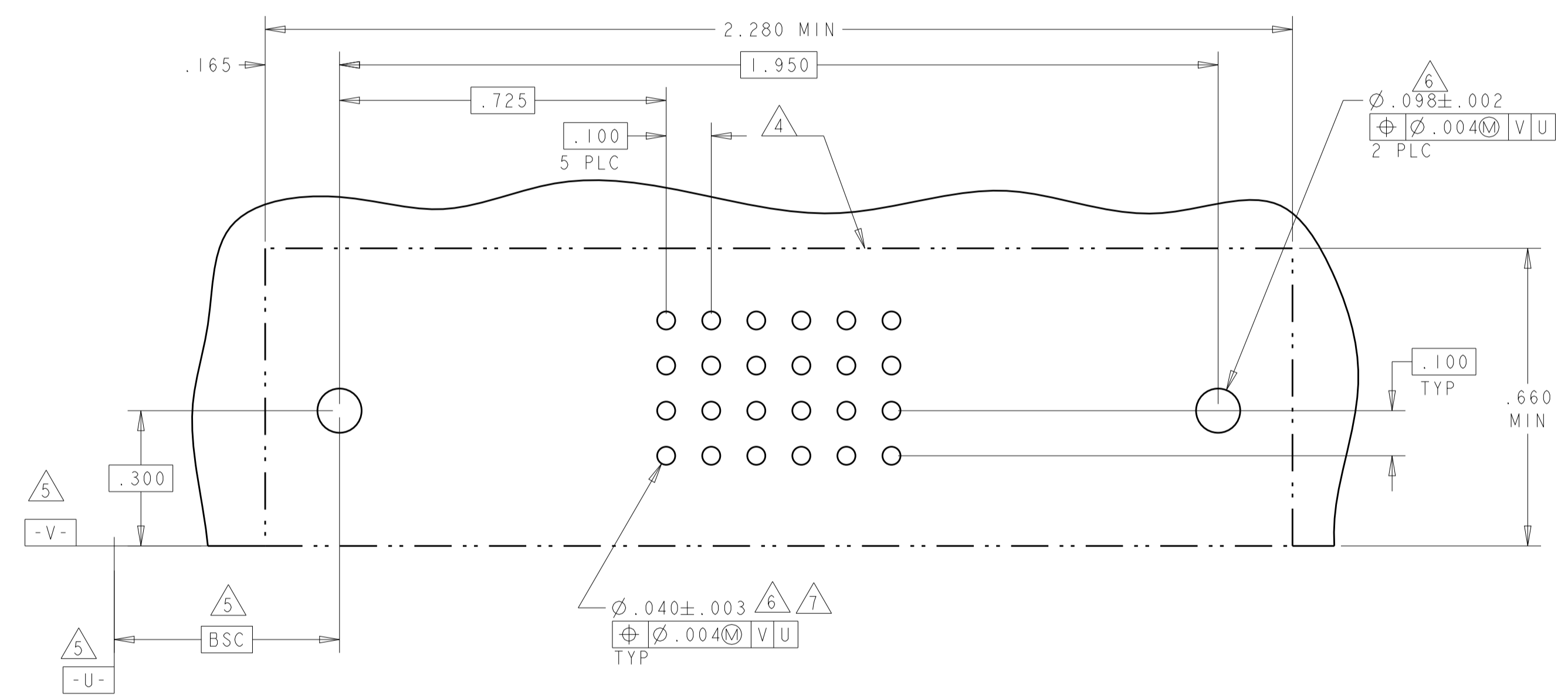

PART NUMBER	ROWS	SIGNAL				POWER			
		1	2	3	4	P1	P2	P3	P4
2-6450131-2	D	J	J	J	J	PM	PM	PM	PM
	C	K	K	K	K				
	B	N	N	N	N				
	A	H	S	S	S				

16S + 4P

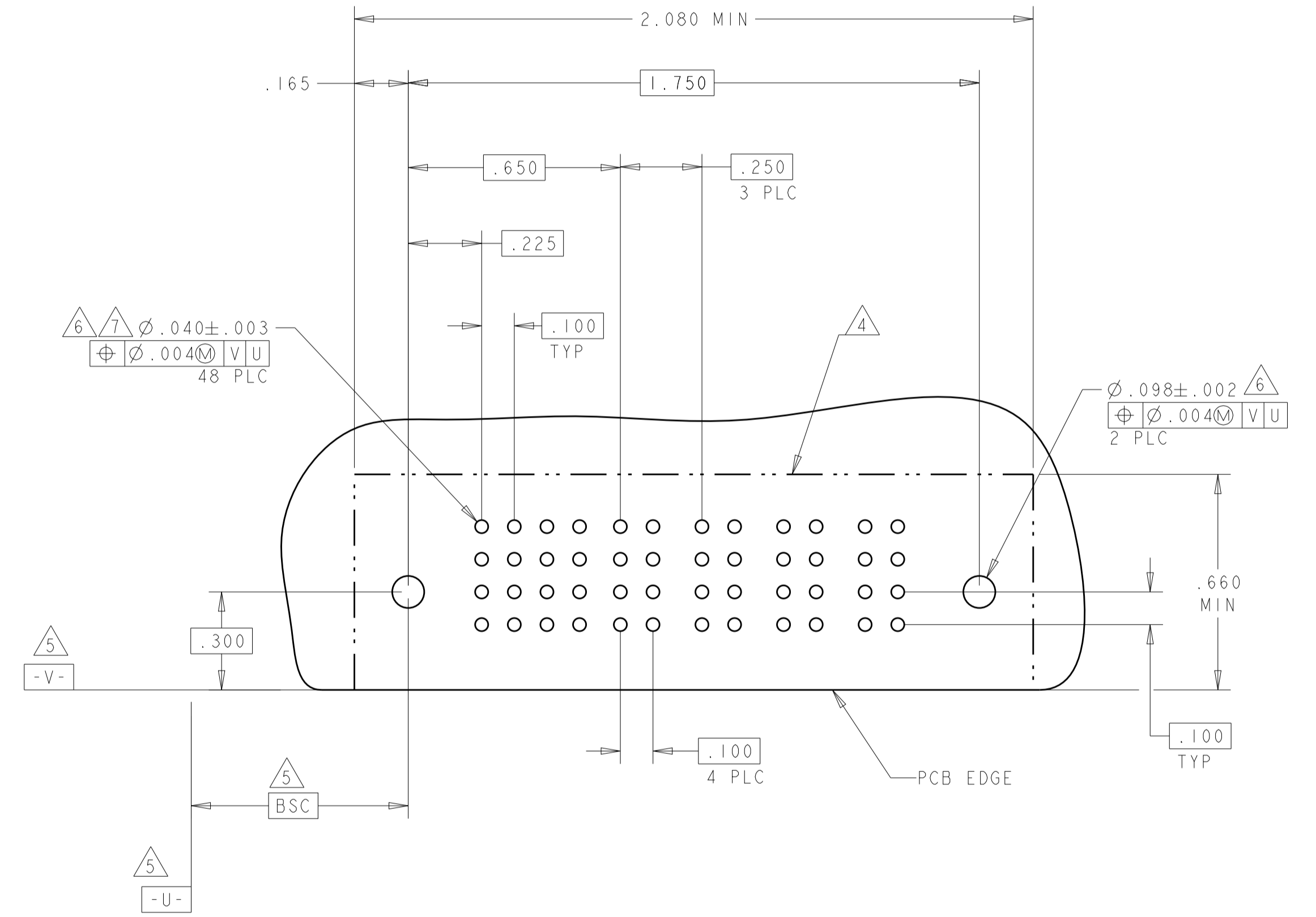

THIS DRAWING IS A CONTROLLED DOCUMENT.		OWN: R. GRZYBOWSKI 15FEB05	TE Connectivity
DIMENSIONS: INCHES		CHK: M. PERCHERKE 15FEB05	
TOLERANCES UNLESS OTHERWISE SPECIFIED:		APVD: M. PERCHERKE	NAME: RIGHT ANGLE HEADER ASSY
0 PLC ± .01		PRODUCT SPEC: 108-1973	SOLDER CONTACTS, W/GUIDES
1 PLC ± .01		APPLICATION SPEC: 114-13038	MULTI-BEAM XL
2 PLC ± .01		SIZE: 114-13038	RESTRICTED TO:
3 PLC ± .01		WEIGHT: -	A100779C=6450131
4 PLC ± .002		CUSTOMER DRAWING	SCALE: 2:1 SHEET 8 OF 8 REV: E8
ANGLES: ± 0.25°			
FINISH: -			