



Chipsmall Limited consists of a professional team with an average of over 10 year of expertise in the distribution of electronic components. Based in Hongkong, we have already established firm and mutual-benefit business relationships with customers from,Europe,America and south Asia,supplying obsolete and hard-to-find components to meet their specific needs.

With the principle of “Quality Parts,Customers Priority,Honest Operation,and Considerate Service”,our business mainly focus on the distribution of electronic components. Line cards we deal with include Microchip,ALPS,ROHM,Xilinx,Pulse,ON,Everlight and Freescale. Main products comprise IC,Modules,Potentiometer,IC Socket,Relay,Connector.Our parts cover such applications as commercial,industrial, and automotives areas.

We are looking forward to setting up business relationship with you and hope to provide you with the best service and solution. Let us make a better world for our industry!



## Contact us

Tel: +86-755-8981 8866 Fax: +86-755-8427 6832

Email & Skype: info@chipsmall.com Web: www.chipsmall.com

Address: A1208, Overseas Decoration Building, #122 Zhenhua RD., Futian, Shenzhen, China



**Model 6481  
Test Connector Adapter Set**

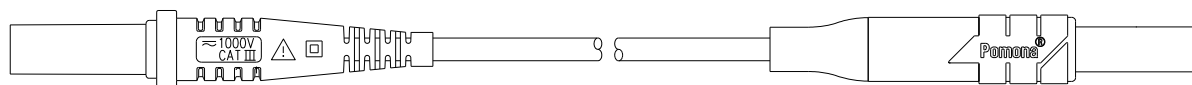

**Model 6358**  
48" (1,2m) Retractable Sheath Modular Test Leads  
Qty 2 - 1 Red, 1 Black

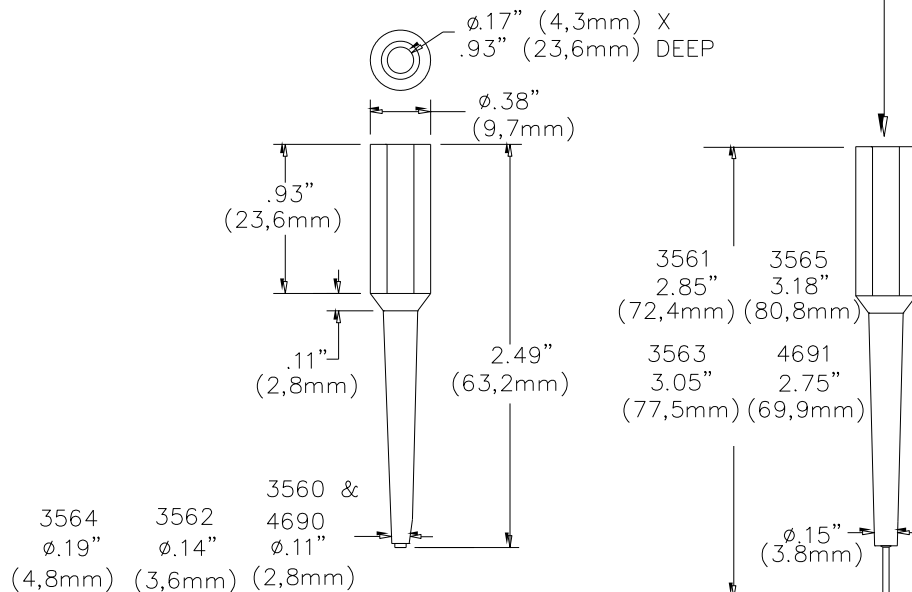
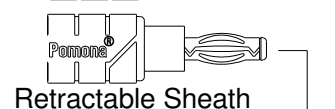

**Features**

- 18-piece kit includes one red and one black set of each pin & socket size along with a set of 48" (1,2m) red and black test leads.
- Test adapters are ideal for rapid testing of the hard-to-get at contacts of multi-pin/socket connectors.
- Round pins and socket adapters.
- Flexible tip allows testing of adjacent contacts.
- Full insulation protects against shorting or contact damage.
- Test leads feature high strand count silicone wire for extreme flexibility and high temperature resistance.
- Model 4690 also fit 0.025in (0.63mm) sq. pins.

Model	Contact Size	Type	Current
4690	22 AWG .030"	Socket	3 Amps
4691	(.76mm)	Pin	
3560	20 AWG .040"	Socket	
3561	(1.02mm)	Pin	
3562	16 AWG .063"	Socket	
3563	(1.60mm)	Pin	
3564	12 AWG .093"	Socket	
3565	(2.36mm)	Pin	

**Voltage Rating:**

For CE compliance and for personal safety, do not hold in hand when voltages exceed 30 Vrms/42.4 Vpk/60 Vdc or current exceeds 8A maximum. Maximum voltage for hands free use: 1000Vrms. Do not use on circuits where transient stresses can exceed the rated voltage.

**USA:** Sales: 800-490-2361  
 Technical Support: [technicalsupport@pomonatest.com](mailto:technicalsupport@pomonatest.com)  
 Fax: 425-446-5844

**Europe:** 31-(0) 40 2675 150 **International:** 425-446-5500  
**Where to Buy:** [www.pomonaelectronics.com](http://www.pomonaelectronics.com)

All dimensions are in inches. Tolerances (except noted): .xx =  $\pm .02''$  (.51 mm), .xxx =  $\pm .005''$  (.127 mm). All specifications are to the latest revisions. Specifications are subject to change without notice. Registered trademarks are the property of their respective companies.



**Model 6481**  
**Test Connector Adapter Set****Materials****Models: 3560, 3562, 3564 & 4690**

Insulation: Polyvinyl chloride (PVC)  
Banana Jack Body (upper connector)  
Material: Brass.  
Finish: Bright Tin plated  
Socket (lower connector):  
Material: Copper Alloy  
Finish: Gold over copper plate

**Models: 3561, 3563, 3565 & 4691**

Insulation: Polyvinyl chloride (PVC).  
Banana Jack Body (upper connector)  
Material: Brass.  
Finish: Bright Tin plated  
Pin (lower connector):  
Material: Brass  
Finish: Gold plated over electroless nickel.

**Model: 6358 Test Leads** (male to male)

Straight Sheath Banana Plug:

*Insulation:* Polypropylene, Color: One Black, One Red

Retractable Sheath Banana Plug:

*Compression Spring:* Stainless Steel*Tip:* Nylon, Color matches Color of Wire*Insulation:* Polypropylene Molded to the Plug and Wire. Color Matches Color of Wire.*Plug Body:* Brass, Nickel Plated*Banana Spring:* Beryllium Copper, Nickel Plated*Wire:* 18 AWG, 192 x 41 bare copper, Silicone Insulation, O.D. 0.144" (3,66mm), Color: One Black, One Red**Ratings****Models: 3560, 3562, 3564, 4690, 3561, 3563, 3565 & 4691 only**

Operating Voltage: For *CE compliance* and for personal safety, do not hold in hand when voltages exceed 30 Vrms/42.4 Vpk/60 Vdc. Maximum voltage for hands free use: 2500 Vrms Max. Do not use on circuits where transient stresses can exceed the rated voltage.

Operating Temperature: +55°C (+131°F) Max.

**(6358\* only):**

Conforms to IEC 61010-031

Operating Voltage: CAT III 1000V

Operating Temperature: +55°C (+131°F) Max.

Current: 10 Amperes

\* *Connectors with retractable insulation sleeves are only for connection to equipment that is NOT provided with terminals which accept fully insulated connectors. These connectors provide NO PROTECTION against electric shock. DO NOT use connectors with retractable insulation sleeves with hand-held probes.*

**Ordering Information**Model: **6481**

Kit contains one red and one black adapter of each model: 3560, 3561, 3562, 3563, 3564, 3565, 4690, 4691 and one set of Model 6358 test leads.

**USA:** Sales: 800-490-2361  
Technical Support: [technicalsupport@pomonatest.com](mailto:technicalsupport@pomonatest.com)  
Fax: 425-446-5844

**Europe:** 31-(0) 40 2675 150 **International:** 425-446-5500

**Where to Buy:** [www.pomonaelectronics.com](http://www.pomonaelectronics.com)

All dimensions are in inches. Tolerances (except noted): .xx = ±.02" (.51 mm), .xxx = ±.005" (.127 mm). All specifications are to the latest revisions. Specifications are subject to change without notice. Registered trademarks are the property of their respective companies.