



Chipsmall Limited consists of a professional team with an average of over 10 year of expertise in the distribution of electronic components. Based in Hongkong, we have already established firm and mutual-benefit business relationships with customers from,Europe,America and south Asia,supplying obsolete and hard-to-find components to meet their specific needs.

With the principle of “Quality Parts,Customers Priority,Honest Operation,and Considerate Service”,our business mainly focus on the distribution of electronic components. Line cards we deal with include Microchip,ALPS,ROHM,Xilinx,Pulse,ON,Everlight and Freescale. Main products comprise IC,Modules,Potentiometer,IC Socket,Relay,Connector.Our parts cover such applications as commercial,industrial, and automotives areas.

We are looking forward to setting up business relationship with you and hope to provide you with the best service and solution. Let us make a better world for our industry!



Contact us

Tel: +86-755-8981 8866 Fax: +86-755-8427 6832

Email & Skype: info@chipsmall.com Web: www.chipsmall.com

Address: A1208, Overseas Decoration Building, #122 Zhenhua RD., Futian, Shenzhen, China



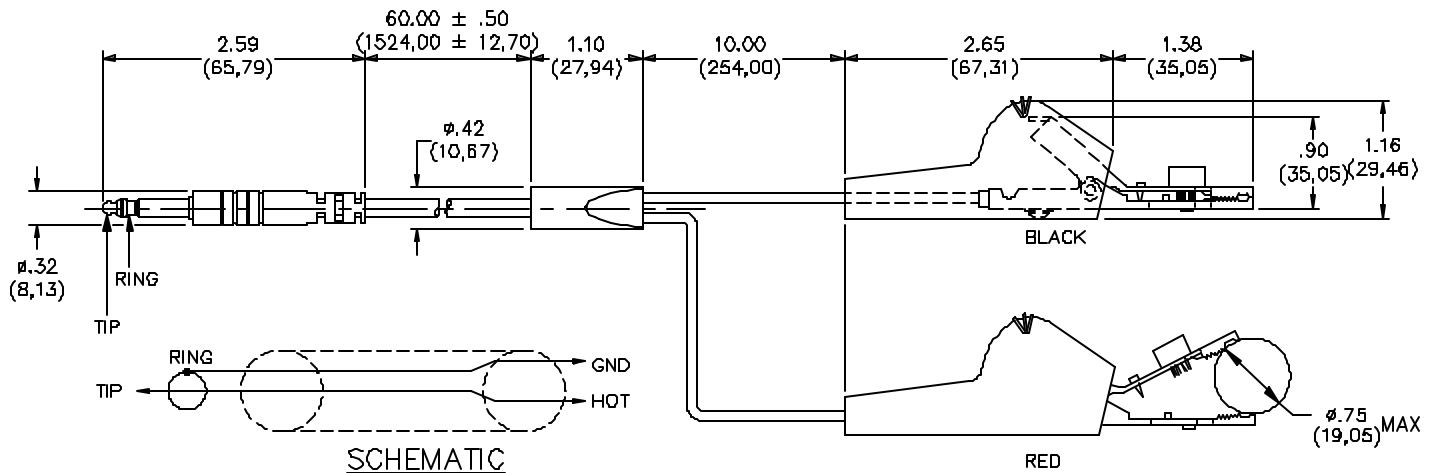

FEATURES:

- Multi-purpose test clips allow five ways to connect to a device under test
 - U-shaped nose for blade shaped terminals
 - Notched jaw for gripping screw heads, bare wire or terminals
 - Serrated teeth for gripping threaded or wire wrapped terminals
 - Cluster of sharp needles for piercing small gauge wires (#22-28 AWG)
 - Large piercing needle for penetrating large gauge wires

MATERIALS:

Jaws: Non-rusting Nickel Copper Alloy.

Boot: Vinyl wire 20 AWG PVC

Cable: 2 conductor, 22 AWG, 7 x 30 tc, 4.6" outside diameter

Y Mold: PVC

Bantam: Miniature phone plug 3 conductor, sleeve no connection

RATINGS:

Operating Voltage: Hand-held 30 VAC/60 VDC

Hands free operation in a controlled voltage environment: 300 VRMS

Current: 5 Amperes

ORDERING INFORMATION: Model 6484-60

All dimensions are in inches. Tolerances (except noted): .xx = ±.02" (.51 mm), .xxx = ± .005" (.127 mm).

All specifications are to the latest revisions. Specifications are subject to change without notice.

Registered trademarks are the property of their respective companies. Made in USA

Sales: 909-469-2900 Fax: 909-629-3317
Technical Assistance: 800-241-2060

PomonaACCESS 90951 (800) 444-6785 or (909) 469-2991
More drawings available at www.pomonaelectronics.com

Standard Length = 60" (152cm)

All dimensions are in inches. Tolerances (except noted): .xx = $\pm .02$ " (.51 mm), .xxx = $\pm .005$ " (.127 mm).

All specifications are to the latest revisions. Specifications are subject to change without notice.

Registered trademarks are the property of their respective companies. Made in USA