



Chipsmall Limited consists of a professional team with an average of over 10 year of expertise in the distribution of electronic components. Based in Hongkong, we have already established firm and mutual-benefit business relationships with customers from,Europe,America and south Asia,supplying obsolete and hard-to-find components to meet their specific needs.

With the principle of "Quality Parts,Customers Priority,Honest Operation,and Considerate Service",our business mainly focus on the distribution of electronic components. Line cards we deal with include Microchip,ALPS,ROHM,Xilinx,Pulse,ON,Everlight and Freescale. Main products comprise IC,Modules,Potentiometer,IC Socket,Relay,Connector.Our parts cover such applications as commercial,industrial, and automotives areas.

We are looking forward to setting up business relationship with you and hope to provide you with the best service and solution. Let us make a better world for our industry!



Contact us

Tel: +86-755-8981 8866 Fax: +86-755-8427 6832

Email & Skype: info@chipsmall.com Web: www.chipsmall.com

Address: A1208, Overseas Decoration Building, #122 Zhenhua RD., Futian, Shenzhen, China



Model 6499
Modular Passive Oscilloscope Probe



Model 6499
Modular Passive Oscilloscope Probe

Accessories included with Probe:

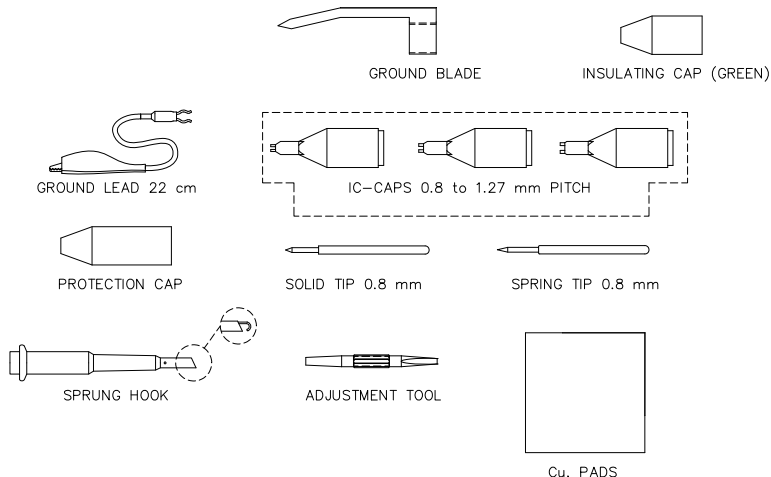

Features

- This probe is recommended for general purpose probing applications and is adjustable for low frequencies.
- The probe's entire core is made of a high quality ceramic hybrid.
- Pure coaxial design and laser trimmed resistors ensure highest signal fidelity along the signal path offering high bandwidth and fast risetimes for accurate impulse measurements.
- Switchable probes offer unbreakable coaxial reed switches for changing between attenuation modes.
- Our passive probes are spring loaded, with needle sharp tips to support precise and safe measurements.
- Probe tips are interchangeable and can be replaced easily.
- Accessories (one of each) included with Probe are:
 - Ground Blade
 - Ground Lead with Alligator Clip 22 cm (8.66")
 - IC Caps: 0.8mm, 1.0mm, and 1.27mm pitch
 - Insulating Cap (green)
 - Protection Cap
 - Solid Tip 0.8mm (0.0315")
 - Spring Tip 0.8mm (0.0315")
 - Sprung Hook
 - Adjustment Tool
 - Copper (Cu) Pads

Specifications

Attenuation Ratio	1:1	10:1
Maximum Input Voltage CAT II ¹	55 Vrms	300 Vrms
Scope Bandwidth MHz	60	
Probe Bandwidth MHz (-3 dB)	20	150
System Risetime (ns)	< 18	< 2.4
Probe Input Resistance (MΩ)	1	10
Probe Input Capacitance (pF)	< 78	< 13
Compensation Range (pF)	-	15 - 40
Cable Length	4 ft. (1.2 m)	

¹ Rating: Per IEC 61010-031. Maximum voltage allowed on the low or ground connection including shell and housing must not exceed 30 V.

Ordering Information

Model: 6499
20/150 MHz X1/X10 Scope Probe

USA: Sales: 800-490-2361
Technical Support: technicalsupport@pomonatest.com
Fax: 425-446-5844

Europe: 31-(0) 40 2675 150 **International:** 425-446-5500
Where to Buy: www.pomonaelectronics.com

All dimensions are in inches. Tolerances (except noted): .xx = ±.02" (.51 mm), .xxx = ±.005" (.127 mm). All specifications are to the latest revisions. Specifications are subject to change without notice. Registered trademarks are the property of their respective companies.