



Chipsmall Limited consists of a professional team with an average of over 10 year of expertise in the distribution of electronic components. Based in Hongkong, we have already established firm and mutual-benefit business relationships with customers from,Europe,America and south Asia,supplying obsolete and hard-to-find components to meet their specific needs.

With the principle of “Quality Parts,Customers Priority,Honest Operation,and Considerate Service”,our business mainly focus on the distribution of electronic components. Line cards we deal with include Microchip,ALPS,ROHM,Xilinx,Pulse,ON,Everlight and Freescale. Main products comprise IC,Modules,Potentiometer,IC Socket,Relay,Connector.Our parts cover such applications as commercial,industrial, and automotives areas.

We are looking forward to setting up business relationship with you and hope to provide you with the best service and solution. Let us make a better world for our industry!



## Contact us

Tel: +86-755-8981 8866 Fax: +86-755-8427 6832

Email & Skype: info@chipsmall.com Web: www.chipsmall.com

Address: A1208, Overseas Decoration Building, #122 Zhenhua RD., Futian, Shenzhen, China



| LOC |     | DIST                      |         | REVISIONS |       |  |  |
|-----|-----|---------------------------|---------|-----------|-------|--|--|
| P   | LTR | DESCRIPTION               | DATE    | OWN       | APP'D |  |  |
| S1  |     | REVISED PER ECO-11-004835 | 11MAR11 | RK        | HMR   |  |  |

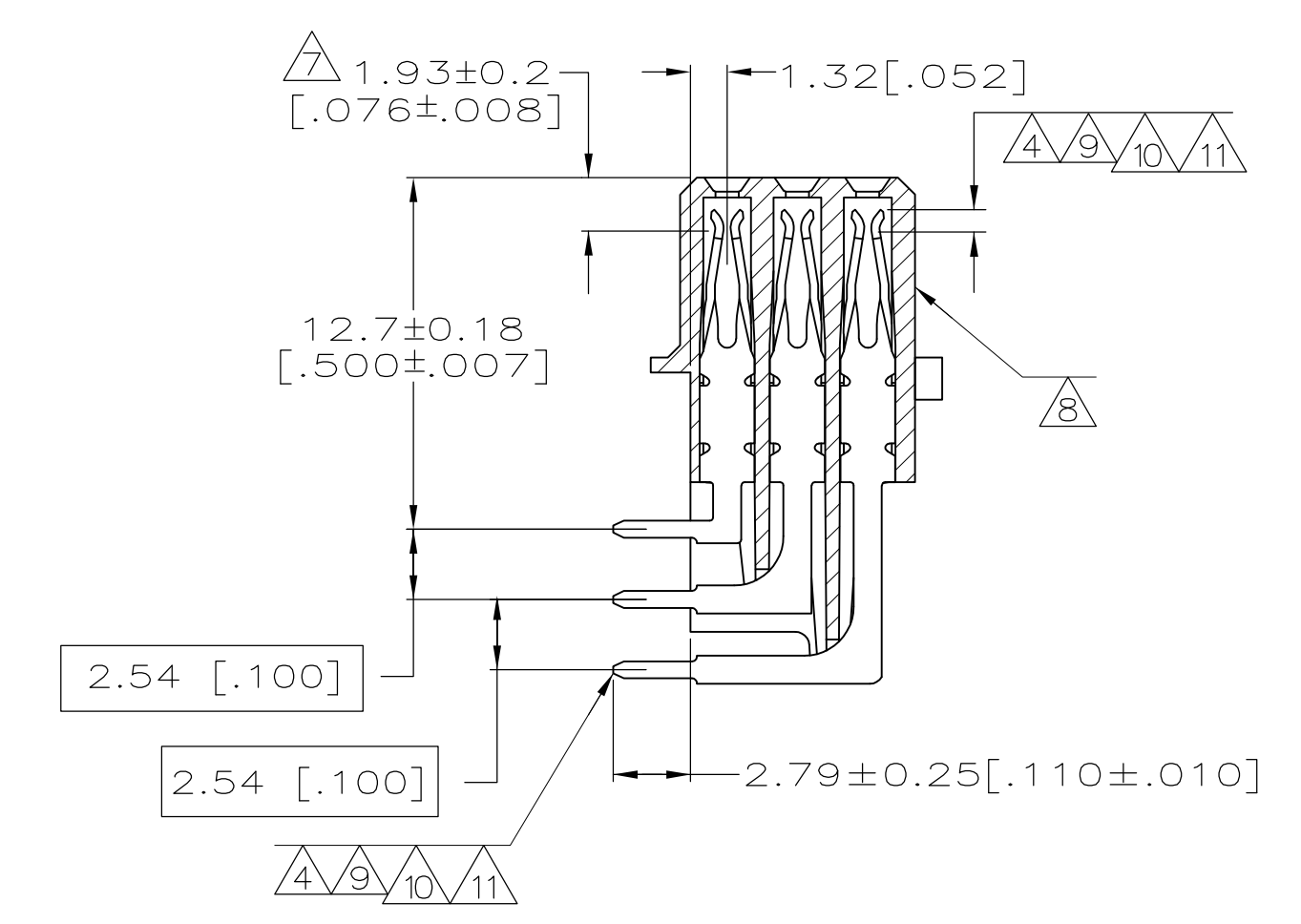
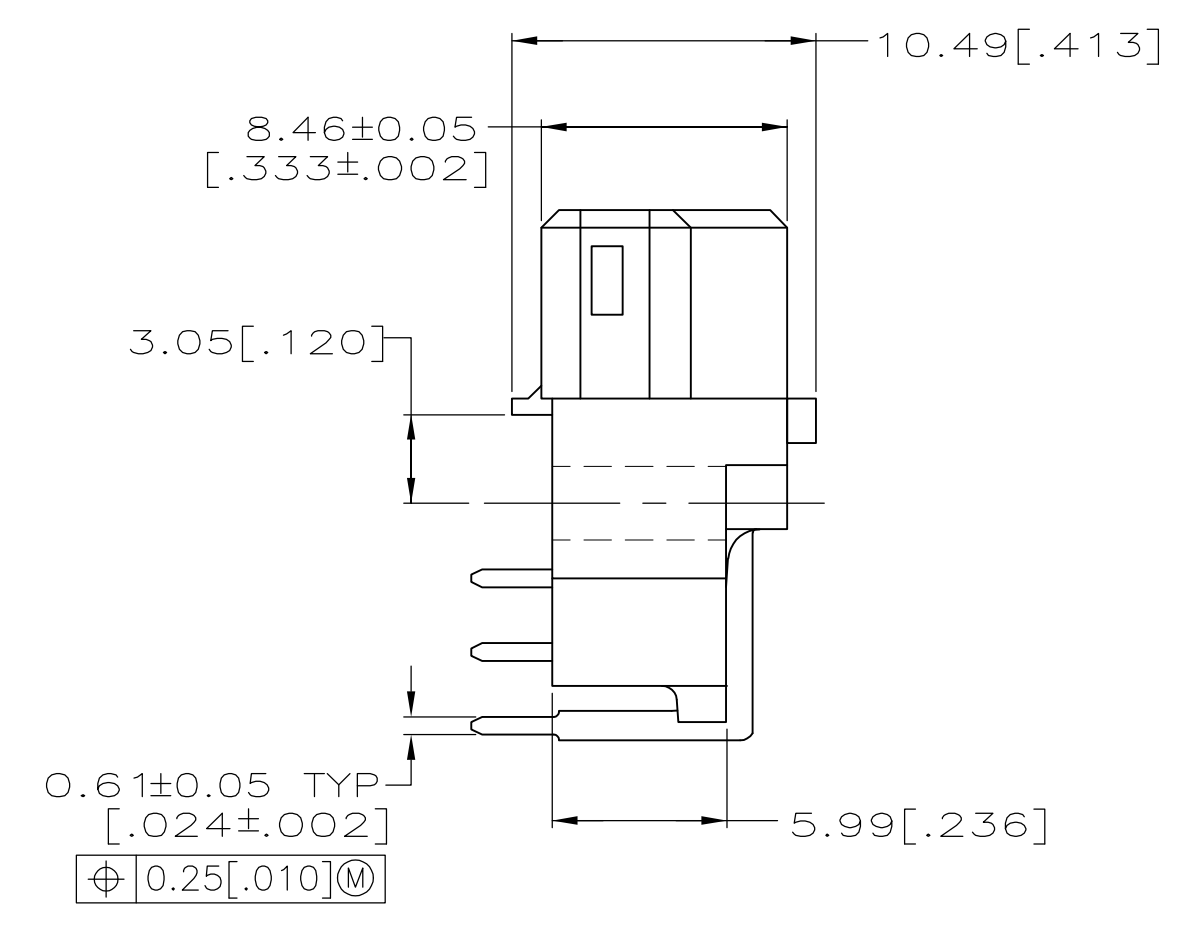
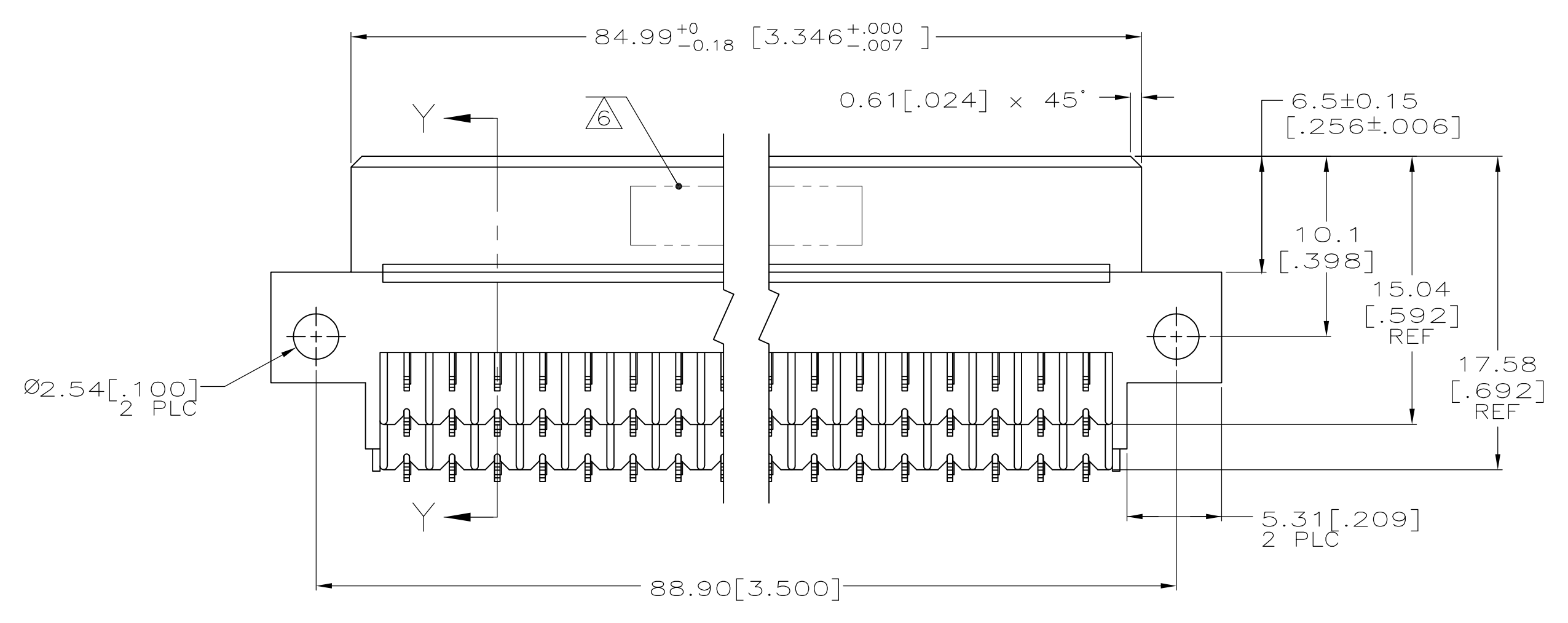
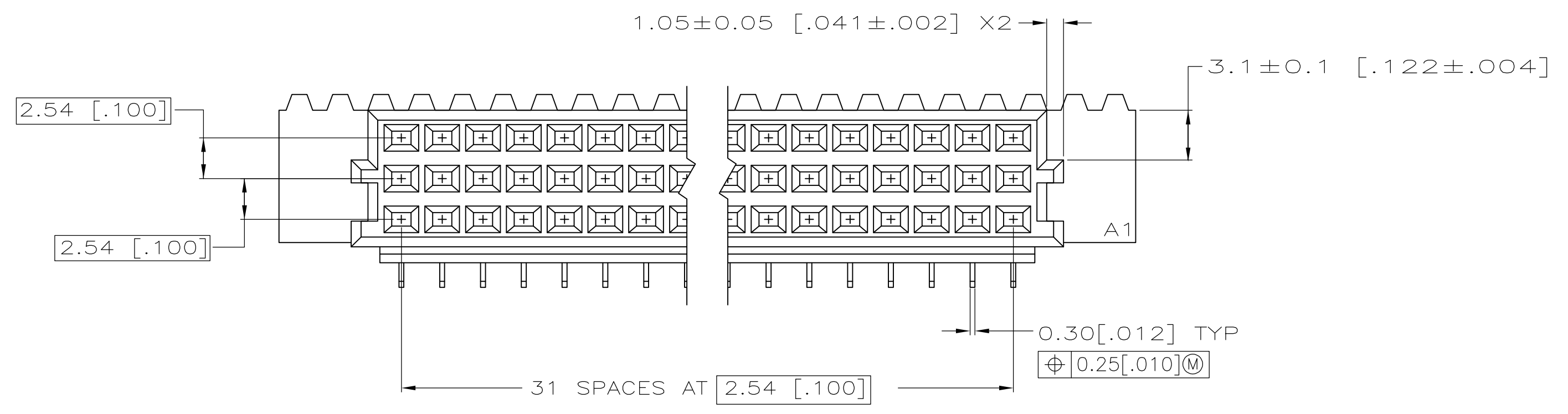

SECTION Y-Y

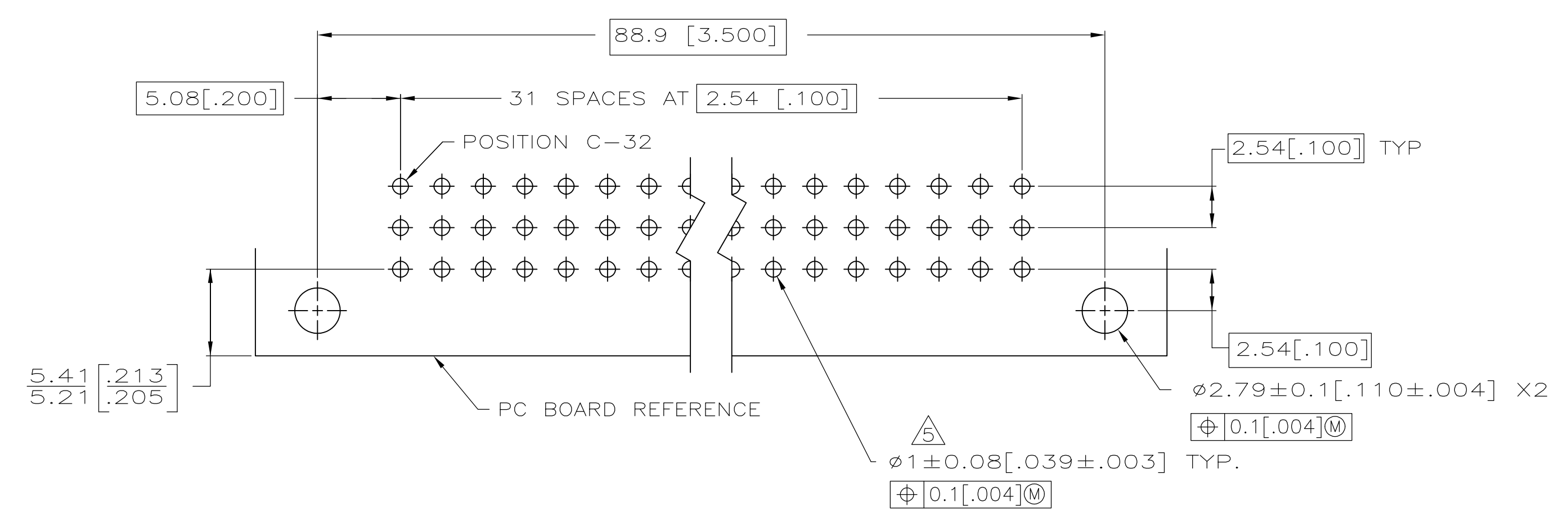
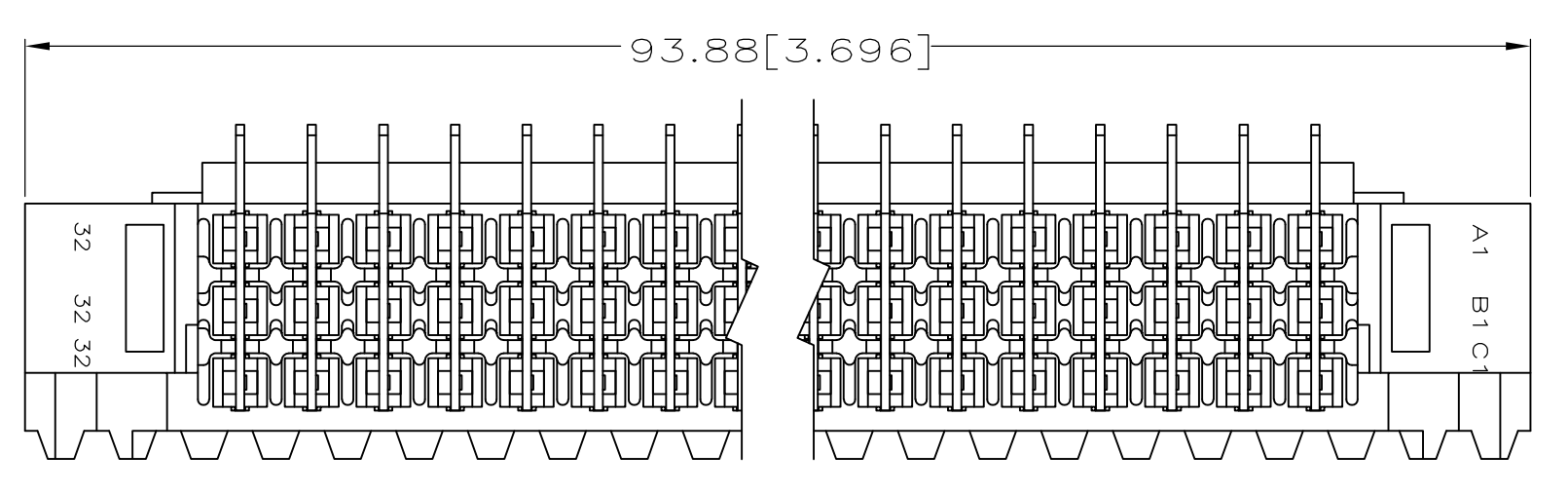

PC BOARD LAYOUT

1. DIMENSIONS IN BRACKETS ARE IN INCHES.
2. HOUSING MATERIAL: GLASS-FILLED POLYESTER. COLOR: GRAY.
3. CONTACT MATERIAL: PHOSPHOR BRONZE.
4. CONTACT FINISH: 0.00076 [.000030] GOLD IN CONTACT AREA. 0.00127 [.000050] NICKEL UNDERPLATE ALL OVER. TIN-LEAD ON POSTS.
5. RECOMMENDED HOLE SIZE FOR MANUAL APPLICATION OF CONNECTOR ONTO PC BOARD.
6. PART NUMBER, DATE CODE IDENTIFICATION, CSA LOGO HOT-STAMPED THIS APPROXIMATE AREA.
7. CONTACT POINT.
8. HOT-STAMPING ON THIS SIDE.
9. CONTACT FINISH: DIN 41612 CLASS 3 IN CONTACT AREA. TIN-LEAD ON POSTS.
10. CONTACT FINISH: 0.00127 [.000050] GOLD IN CONTACT AREA. 0.00127 [.000050] NICKEL UNDERPLATE ALL OVER. TIN-LEAD ON POSTS.
11. CONTACT FINISH: DIN 41612 CLASS 2 IN CONTACT AREA. TIN-LEAD ON POSTS.

| OBSOLETE | REV | DESCRIPTION | POSITIONS LOADED |   |   | NO. OF LOADED POSITION | ASSY PART NUMBER |
|----------|-----|-------------|------------------|---|---|------------------------|------------------|
|          |     |             | C                | B | A |                        |                  |
|          | 9   | 1 THRU 32   | X                | X | X | 96                     | 650461-9         |
|          | 11  | 1 THRU 32   | X                | X | X | 96                     | 650461-6         |
|          | 11  | 1 THRU 32   | X                | X | X | 96                     | 650461-5         |
|          | 4   | 1 THRU 32   | X                | X | X | 96                     | 650461-4         |
|          | 10  | 1 THRU 32   | X                | X | X | 96                     | 650461-1         |

|  |       |                  |         |   |  |
|--|-------|------------------|---------|---|--|
| THIS DRAWING IS A CONTROLLED DOCUMENT. |       | OWN: L. BRINER   | 13MAR90 | NAME  |  |
| DIMENSIONS: mm(INCHES)                 |       | CHK: N. DRASHER  | 24OCT90 | ASSEMBLY, RECEPTACLE, EUROCARD, TYPE R, 96 POSITION |  |
| TOLERANCES UNLESS OTHERWISE SPECIFIED: |       | APVD: N. DRASHER | 24OCT90 | PRODUCT SPEC  |  |
| 0 PLC                                  | ± .01 | APPLICATION SPEC |         | SIZE: CAGE CODE: DRAWING NO:                        |  |
| 1 PLC                                  | ± .02 | WEIGHT           |         | A1 00779 C=650461                                   |  |
| 2 PLC                                  | ± .03 | SCALE            |         | 4:1   |  |
| 3 PLC                                  | ± .04 | SHEET            |         | 1 OF 1  |  |
| 4 PLC                                  | ± .05 | REV              |         | S1  |  |
| ANGLES                                 | ± .05 | CUSTOMER DRAWING |         |   |  |