



Chipsmall Limited consists of a professional team with an average of over 10 year of expertise in the distribution of electronic components. Based in Hongkong, we have already established firm and mutual-benefit business relationships with customers from,Europe,America and south Asia,supplying obsolete and hard-to-find components to meet their specific needs.

With the principle of "Quality Parts,Customers Priority,Honest Operation,and Considerate Service",our business mainly focus on the distribution of electronic components. Line cards we deal with include Microchip,ALPS,ROHM,Xilinx,Pulse,ON,Everlight and Freescale. Main products comprise IC,Modules,Potentiometer,IC Socket,Relay,Connector.Our parts cover such applications as commercial,industrial, and automotives areas.

We are looking forward to setting up business relationship with you and hope to provide you with the best service and solution. Let us make a better world for our industry!



## Contact us

Tel: +86-755-8981 8866 Fax: +86-755-8427 6832

Email & Skype: info@chipsmall.com Web: www.chipsmall.com

Address: A1208, Overseas Decoration Building, #122 Zhenhua RD., Futian, Shenzhen, China



1 2 3 4 5 6

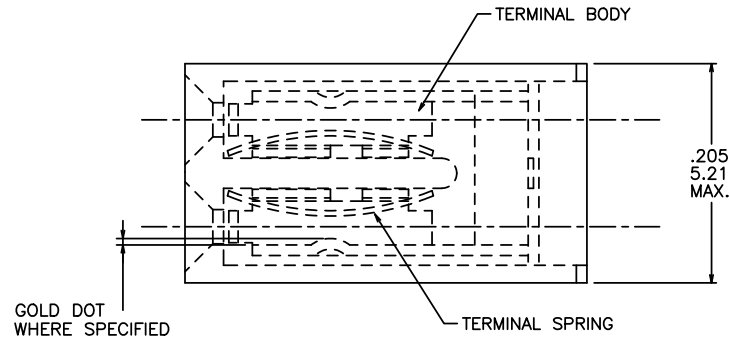

NOTES:

- ① HOUSING MATERIAL IS FLAME RETARDANT PER UL 94V-0 OR EQUIV.
- ② PRODUCT NUMBER 65474-810 TO BE MARKED "BERG" CAGE 22526, DESC XXXXX-XX (NO. TO BE ASSIGNED), AND DATE ON PACKAGING LABEL.
- ③ ADD "LF" SUFFIX AT THE END OF PART NUMBER FOR LEAD FREE OPTION.
- ④ THESE PRODUCTS MEET EUROPEAN UNION DIRECTIVES AND OTHER COUNTRY REGULATIONS AS DESCRIBED IN GS-22-008.
- ⑤ THE PRODUCT IS NOT INTENDED TO BE EXPOSED TO A MANUFACTURING SOLDER PROCESS.
- ⑥ "THIS PRODUCT HAS 100% TIN PLATING IN THE INTERFACE AND HAS NOT BEEN TESTED FOR WHISKERS GROWTH IN ALL INTERCONNECT ENVIRONMENTS."

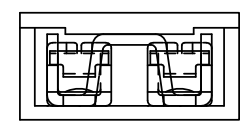
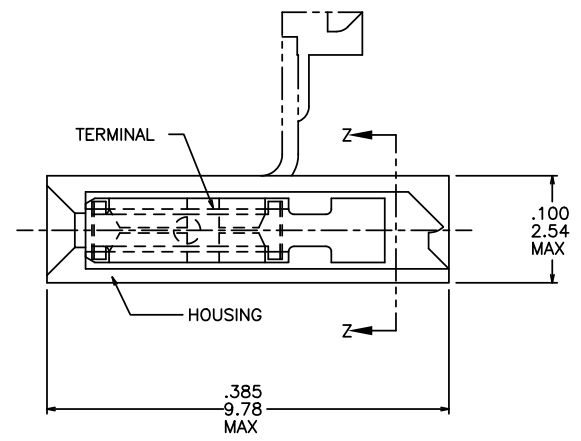
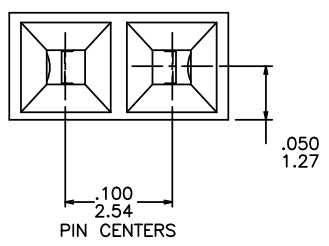

SECTION ZZ

mat'l. code		surface ISO 1302		tolerance ISO 406 ISO 1101		projection INCH/MM		product family JUMPER	
l t r e c n n o d r		date		tolerances unless otherwise specified		INCH/MM		title	
P	V41246 SAR	11/4/94	angles	linea	.XX±.01/.3	scale 6:1		MINI-JUMP ASSEMBLY .100/2.54cc	
R	V50585 SAR	6/26/95	0'±2"		.XXX±.005/.13			dwg no	
S	V50969 SAR	8/3/95			.XXX±.0020/.05			sheet of 2	
T	M05-0205 ERE	09/29/05	dr	S. ROYER	11/4/94	FCI		65474	
U	M06-0238 MN	06/16/08	engr	L. FYE	11/4/94			A3	
V	M06-0389 AGS	10/4/06	chr	L. FYE	11/4/94			type Product Customer Drawing	
W	ELX-N-01189 J.Z	2012-04-24	appd	L. FYE	11/4/94				
sheet	revision	W	W						
index	sheet	1	2						

Copyright FCI  
 FCIconnect.com

Form A3 1 2 3 4 5 6

PRODUCT NUMBER NOTE 3	HOUSING COLOR	TERMINAL BODY		TERMINAL SPRING		HOUSING MATERIAL
		MATERIAL	PLATING	MATERIAL	PLATING	
65474-001	BLUE	.010/.25 THICK 1/4 HD BRASS ALLOY UNS C26000	STRIPE, 40u"/1.02u Au or GXT at CONTACT over 50u"/1.27u Ni	.0048/.122 THICK BE-CU ALLOY UNS C17200 HEAT TREATED	P-Ni/M-050 P-Au/M-003	PLAIN POLYESTER NOTE 1
-002	BLUE	.010/.25 THICK 1/4 HD BRASS ALLOY UNS C26000	SN PLATED	.0048/.122 THICK BE-CU ALLOY UNS C17200 HEAT TREATED	TIN PLATED	PLAIN POLYESTER NOTE 1
-003	DISCONTINUED					
-004	BLUE	.010/.25 THICK 1/4 HD CuNi ALLOY UNS C72500	.001/.03 MIN THICK GOLD DOT	.0048/.122 THICK BE-CU ALLOY UNS C17200 HEAT TREATED	P-Ni/M-050 P-Au/M-003	PLAIN POLYESTER NOTE 1
-005	BLACK	.010/.25 THICK 1/4 HD CuNi ALLOY UNS C72500	.001/.03 MIN THICK GOLD DOT	.0048/.122 THICK BE-CU ALLOY UNS C17200 HEAT TREATED	P-Ni/M-050 P-Au/M-003	PLAIN NORYL NOTE 1
-006	BLACK	.010/.25 THICK 1/4 HD BRASS ALLOY UNS C26000	STRIPE, 40u"/1.02u Au or GXT at CONTACT over 50u"/1.27u Ni	.0048/.122 THICK BE-CU ALLOY UNS C17200 HEAT TREATED	P-Ni/M-050 P-Au/M-003	PLAIN NORYL NOTE 1
-007	SAME AS -004 EXCEPT PACKAGING-RESTRICTED					
-008	SAME AS -004 EXCEPT PACKAGING-RESTRICTED					
-009	BLUE	.010/.25 THICK 1/4 HD BRASS ALLOY UNS C26000	STRIPE, 40u"/1.02u Au or GXT at CONTACT over 50u"/1.27u Ni	.0048/.122 THICK BE-CU ALLOY UNS C17200 HEAT TREATED	30u"/.76u Au	PLAIN NORYL NOTE 1-RESTRICTED
-010	BLUE	.010/.25 THICK 1/4 HD BRASS ALLOY UNS C26000	STRIPE, 30u"/0.76u Au or GXT at CONTACT over 50u"/1.27u Ni	.0048/.122 THICK BE-CU ALLOY UNS C17200 HEAT TREATED	P-Ni/M-050 P-Au/M-003	PLAIN POLYESTER NOTE 1
65474-810	SAME AS -010 EXCEPT ADD SPECIAL MIL MARKING PER NOTE 2					

OB  
OB

FCI  
FCIconnect.com

Copyright FCI

mat'l. code	surface ISO 1302 ✓	tolerance ISO 406 ISO 1101	projection 	product family JUMPER
ltr ecn nchr date	tolerances unless otherwise specified		title MINI-JUMP ASSEMBLY .100/2.54cc	
W	angles linea	.XX±.01/.3 .XXX±.005/.13 .XXX±.0020/.051	INCH/MM scale 6:1	dwg no 65474
	dr S. ROYER	11/4/94		shee 2 of 2 size A3
	enr L. FYE	11/4/94		type Product Customer Drawing
	chr L. FYE	11/4/94		
	app L. FYE	11/4/94		
sheet index	revision sheet			