



Chipsmall Limited consists of a professional team with an average of over 10 year of expertise in the distribution of electronic components. Based in Hongkong, we have already established firm and mutual-benefit business relationships with customers from,Europe,America and south Asia,supplying obsolete and hard-to-find components to meet their specific needs.

With the principle of “Quality Parts,Customers Priority,Honest Operation,and Considerate Service”,our business mainly focus on the distribution of electronic components. Line cards we deal with include Microchip,ALPS,ROHM,Xilinx,Pulse,ON,Everlight and Freescale. Main products comprise IC,Modules,Potentiometer,IC Socket,Relay,Connector.Our parts cover such applications as commercial,industrial, and automotives areas.

We are looking forward to setting up business relationship with you and hope to provide you with the best service and solution. Let us make a better world for our industry!



Contact us

Tel: +86-755-8981 8866 Fax: +86-755-8427 6832

Email & Skype: info@chipsmall.com Web: www.chipsmall.com

Address: A1208, Overseas Decoration Building, #122 Zhenhua RD., Futian, Shenzhen, China



Model 656P/L

Advanced PLL LVPECL or LVDS Clock

Features

- Ceramic Surface Mount Package
- Low Phase Jitter Performance, 500fs Typical
- Advanced PLL Design w/ Low Fundamental Crystal
- Frequency Range 10MHz – 1.0GHz *
- +2.5V or +3.3V Operation
- Output Enable Standard, Pin 2 Option Available
- Tape and Reel Packaging, EIA-418

Applications

- Broadcast Video Systems
- Storage Area Networking
- Broadband Access
- PCI Express
- Networking Equipment
- Ethernet/GbE/SyncE
- Fiber Channel
- Test and Measurement

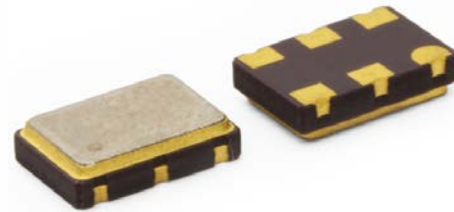

Part Dimensions:
7.0 × 5.0 × 2.0mm • 178.462mg

Standard Frequencies

- 25.00MHz	- 125.00MHz	- 250.00MHz
- 27.00MHz	- 148.50MHz	- 312.50MHz
- 50.00MHz	- 153.60MHz	- 322.265625MHz
- 74.25MHz	- 155.52MHz	- 400.00MHz
- 100.00MHz	- 156.25MHz	- 622.08MHz
- 106.25MHz	- 200.00MHz	

* See Page 8 for additional developed frequencies.
Check with factory for availability of frequencies not listed.

Description

CTS Model 656P/L is a low cost, high performance PLL clock oscillator supporting differential LVPECL or LVDS outputs. Employing the latest IC technology, M656P/L has excellent stability and low phase jitter performance.

Ordering Information

Model	Output Type	Frequency Code [MHz]	Frequency Stability	Temperature Range	Supply Voltage	Packaging
656	P	XXX or XXXX	3	I	3	T

Code	Output
P	LVPECL - Pin 1 Enable
L	LVDS - Pin 1 Enable
E	LVPECL - Pin 2 Enable
V	LVDS - Pin 2 Enable

Code	Stability
6	±20ppm ²
5	±25ppm ³
4	±30ppm
3	±50ppm

Code	Voltage
2	+2.5Vdc
3	+3.3Vdc

Code	Frequency
	Product Frequency Code ¹

Code	Temp. Range
C	-20°C to +70°C
I	-40°C to +85°C

Code	Packing
T	1k pcs./reel

Notes:

- 1] Refer to document 016-1454-0, Frequency Code Tables.
3-digits for frequencies <100MHz, 4-digits for frequencies 100MHz or greater.
- 2] 6I Stability/Temperature combination not available.
- 3] Check factory availability when paired with 'I' temperature code.

**Not all performance combinations and frequencies may be available.
Contact your local CTS Representative or CTS Customer Service for availability.**

This product is specified for use only in standard commercial applications. Supplier disclaims all express and implied warranties and liability in connection with any use of this product in any non-commercial applications or in any application that may expose the product to conditions that are outside of the tolerances provided in its specification.



Electrical Specifications

Operating Conditions

PARAMETER	SYMBOL	CONDITIONS	MIN	TYP	MAX	UNIT
Maximum Supply Voltage	V_{CC}	-	-0.5	-	4.0	V
Supply Voltage	V_{CC}	±5%	2.375 3.135	2.5 3.3	2.625 3.465	V
Supply Current						
LVPECL	I_{CC}	Maximum Load Maximum Current Value @ +3.3V	-	54	88	mA
LVDS			-	23	65	
Operating Temperature	T_A	-	-20 -40	+25	+70 +85	°C
Storage Temperature	T_{STG}	-	-55	-	+125	°C

Frequency Stability

PARAMETER	SYMBOL	CONDITIONS	MIN	TYP	MAX	UNIT
Frequency Range	f_O	-		10 - 1000		MHz
Frequency Stability [Note 1]	$\Delta f/f_O$	-		20, 25 or 50		±ppm
Aging	$\Delta f/f_{25}$	First Year @ +25°C, nominal V_{CC}	-3	-	3	ppm

1.] Inclusive of initial tolerance at time of shipment, changes in supply voltage, load, temperature and 1st year aging.

Output Parameters

PARAMETER	SYMBOL	CONDITIONS	MIN	TYP	MAX	UNIT
Output Type	-	-		LVPECL		-
Output Load	R_L	Terminated to $V_{CC} - 2.0V$	-	50	-	Ohms
Output Voltage Levels	V_{OH} V_{OL}	PECL Load	$V_{CC} - 1.03$ $V_{CC} - 1.85$	- -	$V_{CC} - 0.60$ $V_{CC} - 1.60$	V
Output Duty Cycle	SYM	@ $V_{CC} - 1.3V$	45	-	55	%
Rise and Fall Time	T_{R, T_F}	@ 20%/80% Levels, $R_L = 50$ Ohms	-	0.25	0.60	ns
Output Type	-	-		LVDS		-
Output Load	R_L	Between Outputs	-	100	-	Ohms
Output Voltage Levels	V_{OH} V_{OL}	LVDS Load	- 0.90	1.43 1.10	1.60 -	V
Output Duty Cycle	SYM	@ 1.25V	45	-	55	%
Differential Output Voltage	V_{OD}	$R_L = 100$ Ohms	175	330	454	mV
Offset Voltage	V_{OS}	LVDS Load	1.20	1.25	1.30	V
Rise and Fall Time	T_{R, T_F}	@ 20%/80% Levels, $R_L = 100$ Ohms	-	-	0.5	ns

Electrical Specifications

Output Parameters

PARAMETER	SYMBOL	CONDITIONS	MIN	TYP	MAX	UNIT
Start Up Time	T_S	Application of V_{CC}	-	3	5	ms
Enable Function [Tri-State]						
Enable Input Voltage	V_{IH}	Pin 1 or 2 Logic '1', Output Enabled	$0.7V_{CC}$	-	-	V
Disable Input Voltage	V_{IL}	Pin 1 or 2 Logic '0', Output Disabled	-	-	$0.3V_{CC}$	V
Disable Current	I_{IL}	Pin 1 or 2 Logic '0', Output Disabled	-	16	22	mA
Enable Time	T_{PLZ}	Pin 1 or 2 Logic '1', Output Enabled	-	-	200	ns
Phase Jitter, RMS	t_{jrms}	Bandwidth 12 kHz - 20 MHz	-	500	<1000	fs
Period Jitter, RMS	p_{jrms}	-	-	2.5	-	ps
Period Jitter, pk-pk	p_{jpk-pk}	-	-	25	-	ps

Enable Truth Table

Pin 1 or Pin 2	Pin 4 & Pin 5
Logic '1'	Output
Open	Output
Logic '0'	High Imp.

Test Circuit

LVPECL

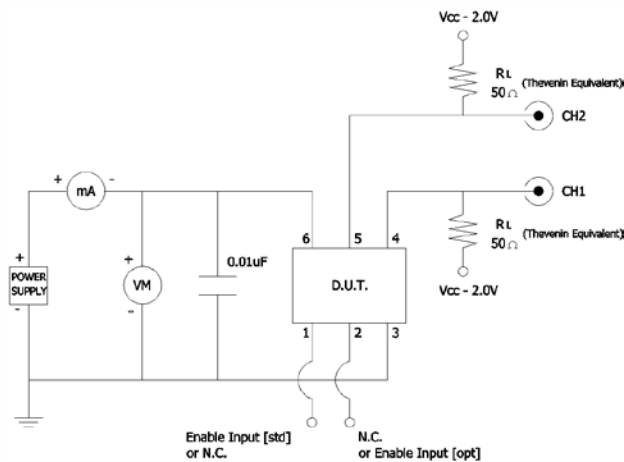

LVDS

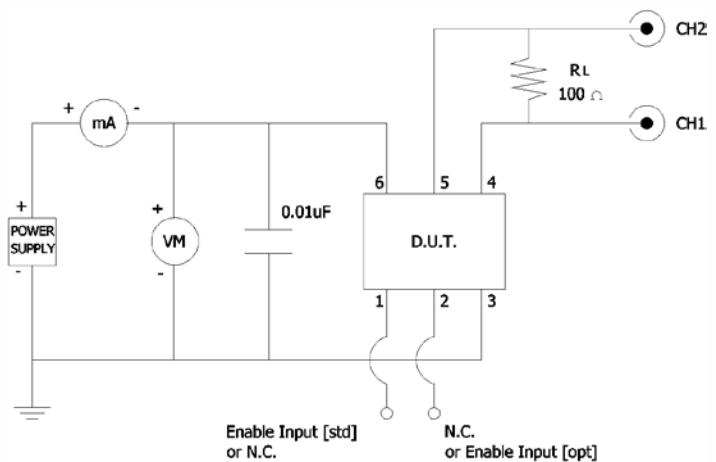

Output Waveform

LVPECL or LVDS

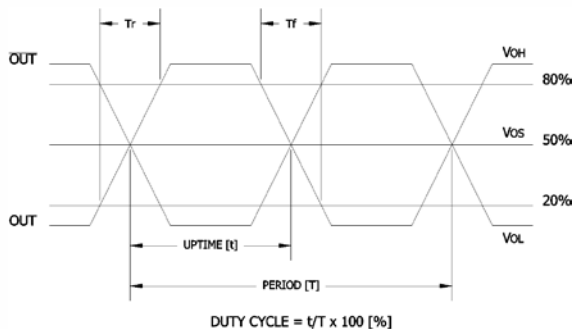

Electrical Specifications

Performance Data

Phase Noise [typical]

100.00MHz, LVPECL, $V_{CC} = 3.3V$, $T_A = +25^\circ C$

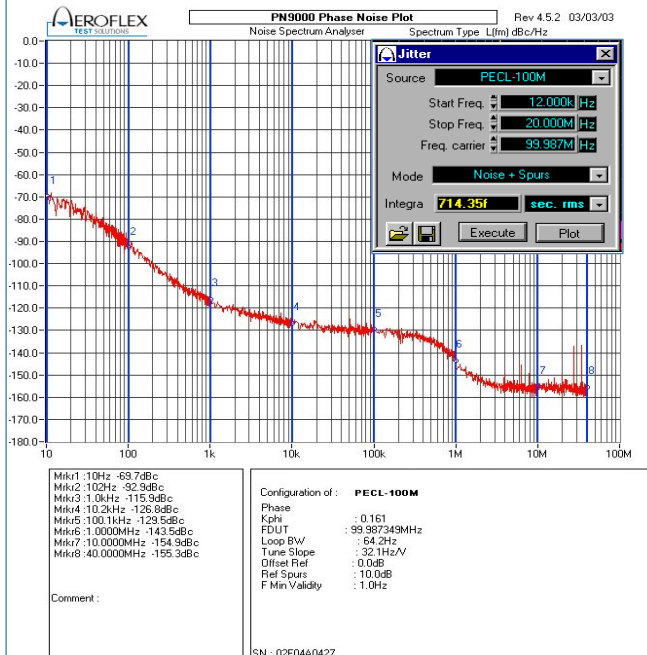

156.25MHz, LVPECL, $V_{CC} = 3.3V$, $T_A = +25^\circ C$

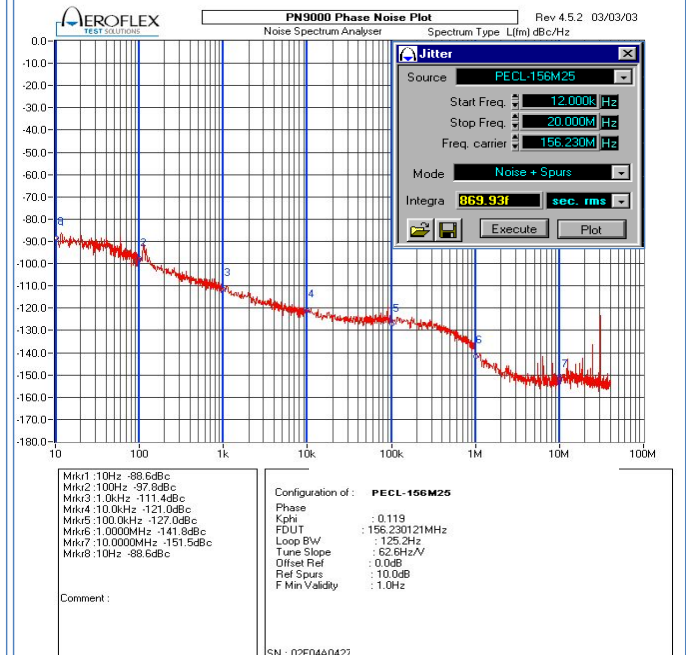

312.50MHz, LVPECL, $V_{CC} = 3.3V$, $T_A = +25^\circ C$

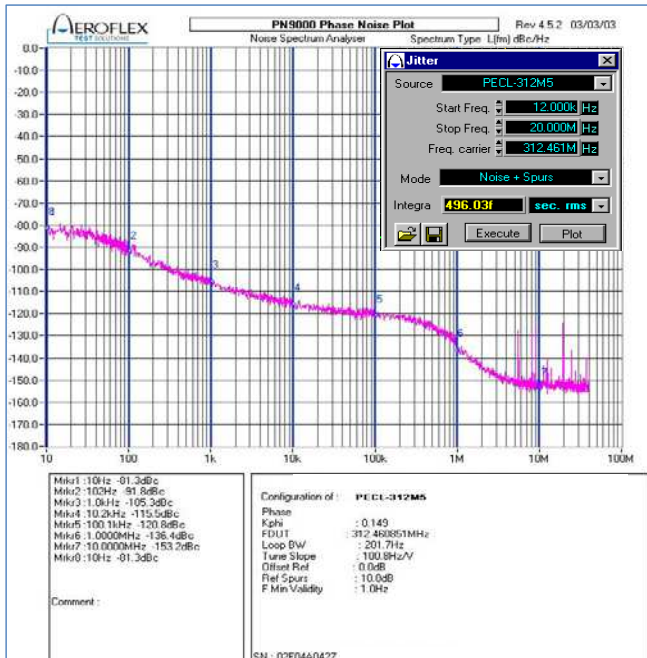

800.00MHz, LVPECL, $V_{CC} = 3.3V$, $T_A = +25^\circ C$

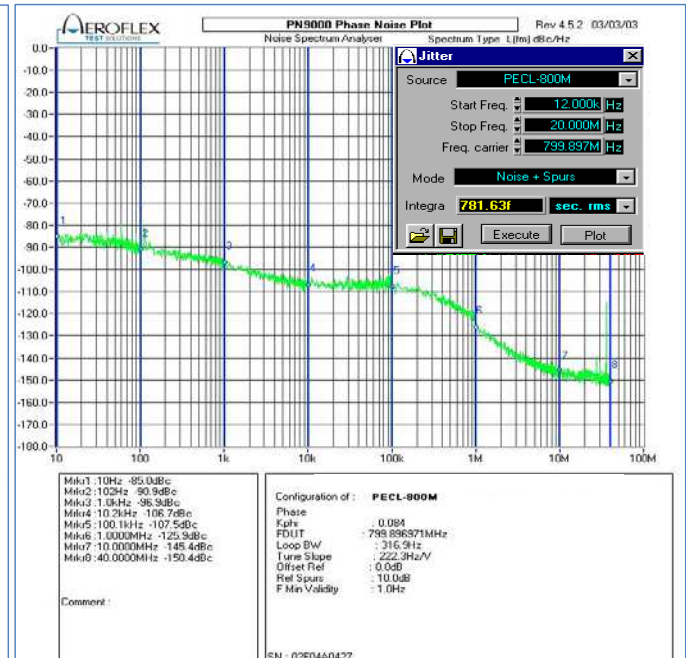



Electrical Specifications

Performance Data

Phase Noise Tabulated

Typical, HCMOS, $V_{CC} = 3.3V$, $T_A = +25^\circ C$

PARAMETER	SYMBOL	CONDITIONS	TYP	UNIT
LVPECL @ 100.00MHz				
Phase Noise		Single Side Band		
		@ 10Hz	-69.70	
		@ 100Hz	-92.90	
		@ 1kHz	-115.90	
	-	@ 10kHz	-126.80	dBc/Hz
		@ 100kHz	-129.50	
		@ 1MHz	-143.50	
		@ 10MHz	-154.90	
		@ 40MHz	-155.30	
Phase Jitter, RMS	tjrms	Integration Bandwidth 12kHz - 20MHz	714.35	fs

PARAMETER	SYMBOL	CONDITIONS	TYP	UNIT
LVPECL @ 312.50MHz				
Phase Noise		Single Side Band		
		@ 10Hz	-81.30	
		@ 100Hz	-91.80	
		@ 1kHz	-105.30	
	-	@ 10kHz	-115.50	dBc/Hz
		@ 100kHz	-120.80	
		@ 1MHz	-136.40	
		@ 10MHz	-153.20	
		@ 40MHz	-153.20	
Phase Jitter, RMS	tjrms	Integration Bandwidth 12kHz - 20MHz	496.03	fs

PARAMETER	SYMBOL	CONDITIONS	TYP	UNIT
LVPECL @ 156.25MHz				
Phase Noise		Single Side Band		
		@ 10Hz	-88.60	
		@ 100Hz	-97.80	
		@ 1kHz	-111.40	
	-	@ 10kHz	-121.00	dBc/Hz
		@ 100kHz	-127.00	
		@ 1MHz	-141.80	
		@ 10MHz	-151.50	
		@ 40MHz	-153.30	
Phase Jitter, RMS	tjrms	Integration Bandwidth 12kHz - 20MHz	869.93	fs

PARAMETER	SYMBOL	CONDITIONS	TYP	UNIT
LVPECL @ 800.00MHz				
Phase Noise		Single Side Band		
		@ 10Hz	-85.00	
		@ 100Hz	-90.90	
		@ 1kHz	-96.90	
	-	@ 10kHz	-106.70	dBc/Hz
		@ 100kHz	-107.50	
		@ 1MHz	-125.90	
		@ 10MHz	-145.40	
		@ 40MHz	-150.40	
Phase Jitter, RMS	tjrms	Integration Bandwidth 12kHz - 20MHz	781.63	fs

Mechanical Specifications

Package Drawing

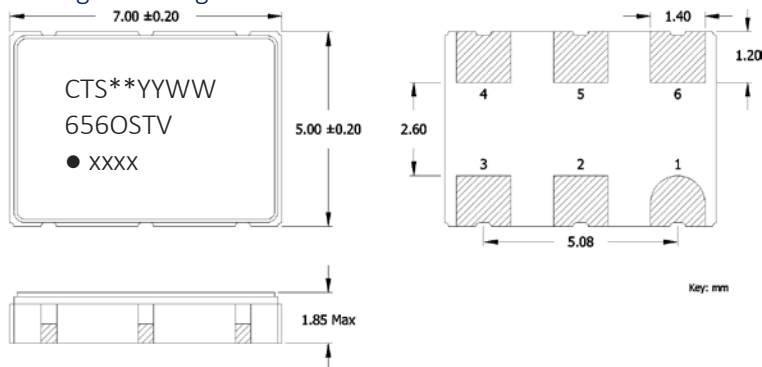

Marking Information

- ** - Manufacturing Site Code.
- YYWW – Date Code; YY – year, WW – week.
- O – Output Type; P = LVPECL, L = LVDS.
- ST – Frequency Stability/Temperature Code. [Refer to Ordering Information]
- V – Voltage Code; 3 = 3.3V, 2 = 2.5V.
- xxxx – Frequency Code.
3-digits, frequencies below 100MHz
4-digits, frequencies 100MHz or greater
[See document 016-1454-0, Frequency Code Tables.]

Recommended Pad Layout

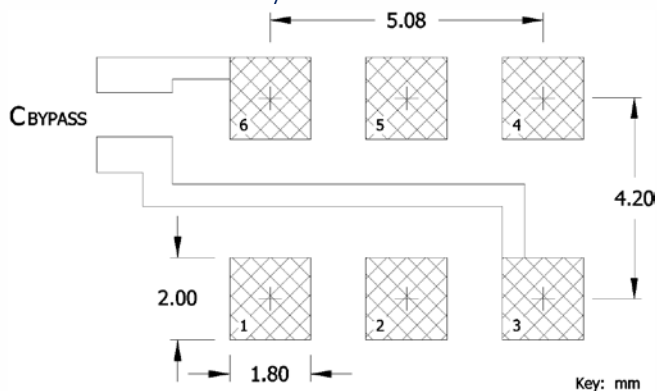

Notes

- JEDEC termination code (e4). Barrier-plating is nickel [Ni] with gold [Au] flash plate.
- Reflow conditions per JEDEC J-STD-020; +260°C maximum, 20 seconds.
- MSL = 1.

Pin Assignments

Pin	Symbol	Function
1	EOH or N.C.	Enable [std] or No Connect
2	N.C. or EOH	No Connect or Enable [opt]
3	GND	Circuit & Package Ground
4	Output	RF Output
5	Output	Complimentary RF Output
6	V _{CC}	Supply Voltage

Packaging - Tape and Reel

Tape Drawing

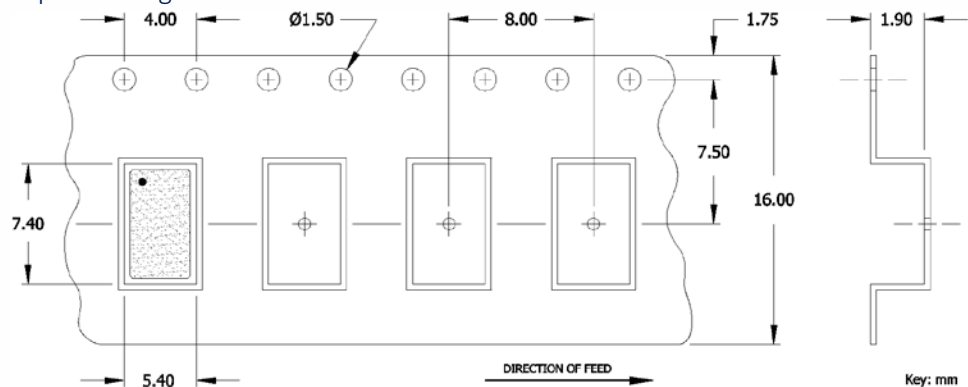

Reel Drawing

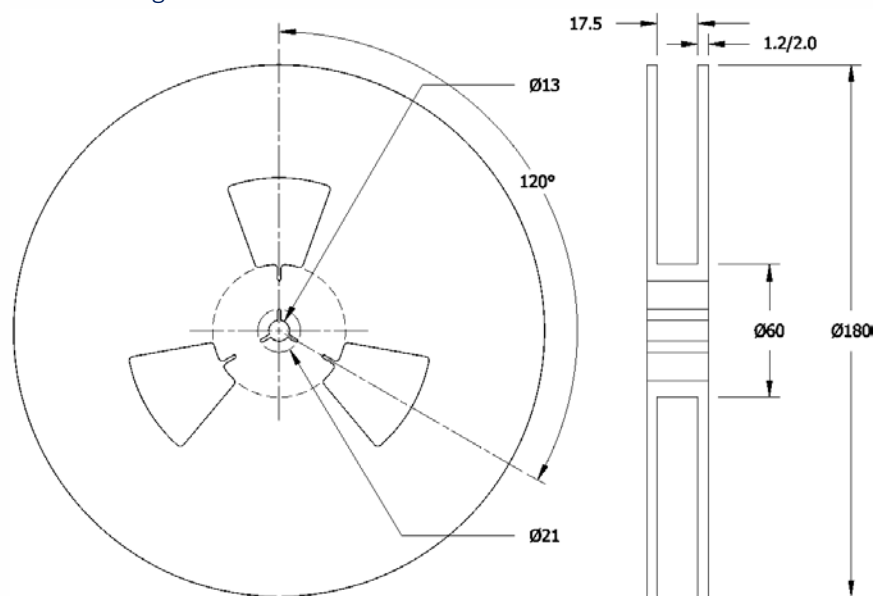

Notes

1. Device quantity is 1k pieces maximum per 180mm reel.
2. Complete CTS part number, frequency value and date code information must appear on reel and carton labels.



Addendum

Additional Developed Frequencies – MHz

FREQUENCY	FREQUENCY CODE	FREQUENCY	FREQUENCY CODE	FREQUENCY	FREQUENCY CODE	FREQUENCY	FREQUENCY CODE
38.840000	38D	87.351542	873	150.000000	1500	644.531250	6445
38.880000	388	92.160000	921	156.253906	156A	669.326500	6693
43.350000	433	96.000000	960	160.000000	1600	693.483000	6934
45.000000	450	104.000000	1040	161.132800	1611	983.040000	9830
54.000000	540	122.880000	1228	184.320000	1843		
62.500000	625	132.000000	1320	204.800000	2048		
74.175800	74A	135.000000	1350	233.000000	2330		
76.800000	768	144.500000	1445	245.760000	2457		
77.760000	777	148.351600	148A	300.000000	3000		
86.700000	867	148.351648	148B	349.400000	3494		

Frequency Codes for Cover Page Table – MHz

FREQUENCY	FREQUENCY CODE	FREQUENCY	FREQUENCY CODE	FREQUENCY	FREQUENCY CODE	FREQUENCY	FREQUENCY CODE
25.000000	250	106.250000	1062	156.250000	1562	400.000000	4000
27.000000	270	125.000000	1250	200.000000	2000	622.080000	6220
50.000000	500	148.500000	1485	250.000000	2500		
74.250000	742	153.600000	1536	312.500000	3125		
100.000000	1000	155.520000	1555	322.265625	322A		