

Chipsmall Limited consists of a professional team with an average of over 10 year of expertise in the distribution of electronic components. Based in Hongkong, we have already established firm and mutual-benefit business relationships with customers from,Europe,America and south Asia,supplying obsolete and hard-to-find components to meet their specific needs.

With the principle of “Quality Parts,Customers Priority,Honest Operation,and Considerate Service”,our business mainly focus on the distribution of electronic components. Line cards we deal with include Microchip,ALPS,ROHM,Xilinx,Pulse,ON,Everlight and Freescale. Main products comprise IC,Modules,Potentiometer,IC Socket,Relay,Connector.Our parts cover such applications as commercial,industrial, and automotives areas.

We are looking forward to setting up business relationship with you and hope to provide you with the best service and solution. Let us make a better world for our industry!



Contact us

Tel: +86-755-8981 8866 Fax: +86-755-8427 6832

Email & Skype: info@chipsmall.com Web: www.chipsmall.com

Address: A1208, Overseas Decoration Building, #122 Zhenhua RD., Futian, Shenzhen, China

THIS DRAWING AND THE SUBJECT MATTER SHOWN THEREON ARE CONFIDENTIAL AND THE PROPERTY OF BEL/STEWART/TRP CONNECTOR AND SHALL NOT BE REPRODUCED, COPIED, OR USED IN ANY MANNER WITHOUT THE WRITTEN CONSENT OF TRP CONNECTOR.

PRODUCT MAY BE PROTECTED BY ONE OR MORE OF THE FOLLOWING US PATENTS:
 5736910 5939955 6425781 6428361 6554638 6840817 7123117
 7429195 7717749 7808751 6217391 6149050 7924130

REVISIONS				
REV	DATE	DESCRIPTION	BY	APP
F		EC-1411035 COMPANY LOGO CHANGE	30DEC2014	ST TL

MECHANICAL:

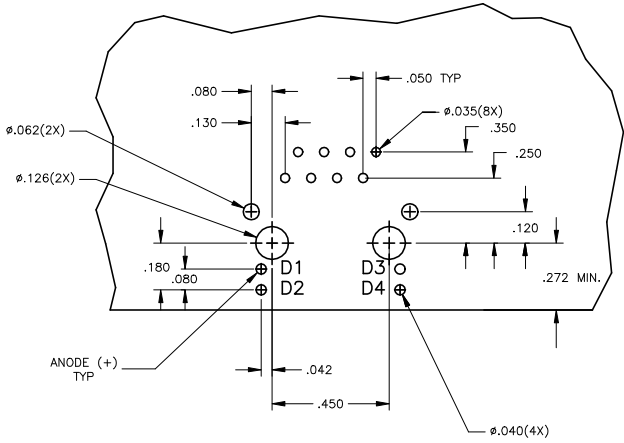
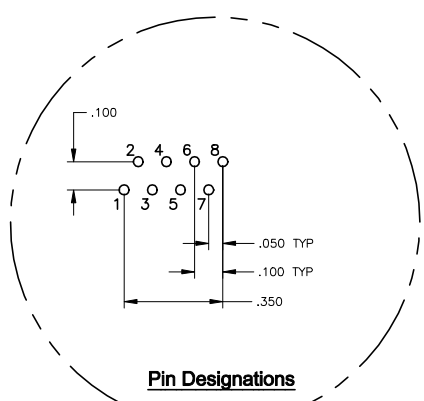
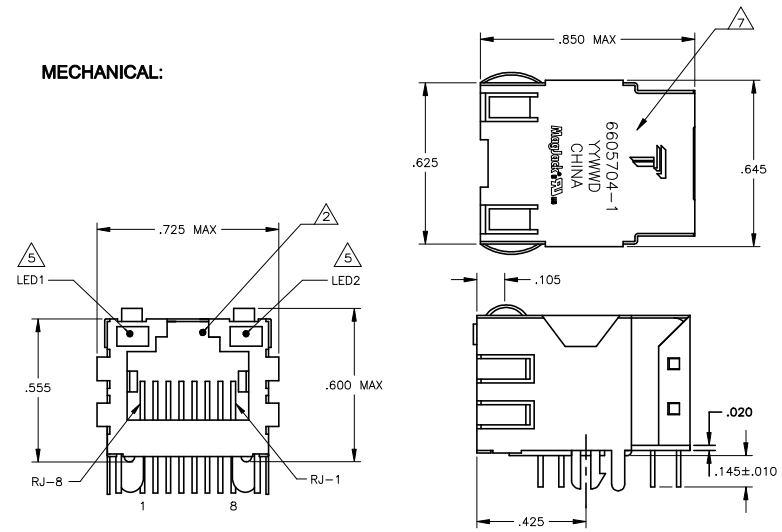

**ELECTRICAL:
706ET MAGNETIC CIRCUIT**

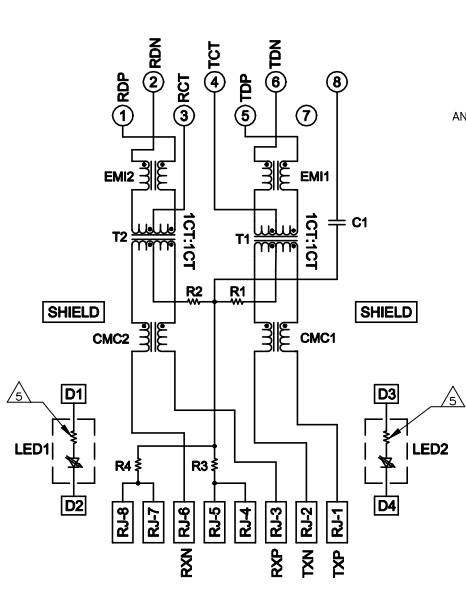

C1=1000PF, 2kV CAPACITOR
 R1-R4 = 75 OHMS, 1/16 W RESISTORS

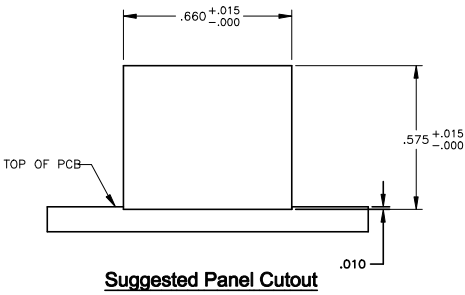

- 1 MATERIALS:
 HOUSING - THERMOPLASTIC PET POLYESTER FLAMMABILITY RATING UL 94V-0.
 SHIELD - .010" THICK, C26800 BRASS PREPLATED WITH 30µINCH MIN SEMI-BRIGHT NICKEL. SOLDER TABS POST DIPPED WITH 100µINCH MIN SAC SOLDER.
 MOD JACK CONTACTS - 0.0157 X 0.018" PHOSPHOR BRONZE, 50µINCH MIN OVERALL NICKEL UNDERPLATE WITH SELECT 50µINCH MIN HARD GOLD FINISH PLATE.
 SOLDER TAILS WITH 100µINCH MIN MATTE TIN AND/OR SAC SOLDER DIP.
 LIGHT EMITTING DIODE(LED) - DIFFUSED EPOXY LENS, .020" X .020" CARBON STEEL WIREFRAME LEADS PRE-PLATED WITH 80µINCH SILVER OVER 40µINCH NICKEL UNDERPLATE OVER 40µINCH COPPER UNDERPLATE. POST-PLATED WITH 100µINCH MIN MATTE TIN AND/OR SAC SOLDER DIP OR PURE TIN SOLDER DIP.

- △ RJ45 JACK CAVITY CONFORMS TO FCC RULES AND REGULATIONS PART 68, SUB PART F.
 △ MAGNETICS
 -IMPEDANCE: 100 OHMS
 -TURNS RATIO (CHIP-CABLE): TX = 1:1, RX = 1:1
 -OPEN CIRCUIT INDUCTANCE (OCL): 350µH MIN @100kHz, 0.1VRMS, 8mADC BIAS FROM -40°C TO +85°C, TX AND RX
 -PERFORMANCE @ 25°C:
 INSERTION LOSS (IL): 1.1dB MAX FROM 0.5MHz TO 100MHz
 RETURN LOSS (RL): 18dB MIN FROM 0.5MHz TO 30MHz
 18-20LOG(f/30)dB MIN FROM 30.1MHz TO 60MHz
 12dB MIN FROM 60.1MHz TO 80MHz
 CROSSTALK ATTENUATION: 35dB MIN FROM 0.5MHz TO 40MHz
 33-20LOG(f/50)dB MIN FROM 40.1MHz TO 100MHz
 COMMON MODE REJECTION RATIO (CMRR): 30dB MIN FROM 0.5MHz TO 100MHz
 -ISOLATION VOLTAGE:2250VDC (MAX) FOR 60 SECONDS WITH A RISE TIME OF 500V/SEC.

4. OPERATING TEMPERATURE: FROM -40°C TO +85°C INDUSTRIAL TEMPERATURE RATED.

- △ THE 250 OHM LED RESISTORS ARE OPTIONAL, PLEASE SEE CHART FOR PRESENCE OR ABSENCE OF LED RESISTORS. IF THE LED WITHOUT 250 OHM RESISTORS, LED IS DRIVEN WITH CONSTANT CURRENT AT APPROX 20mA.
 LED COLOR: DOMINANT WAVELENGTH (λD): GREEN 568 nm TYP @ IF=20mA
 FORWARD VOLTAGE (VF): GREEN 2.2V TYP @ IF=20mA
 DOMINANT WAVELENGTH (λD): YELLOW 588 nm TYP @ IF=20mA
 FORWARD VOLTAGE (VF): YELLOW 2.1V TYP @ IF=20mA.
 IF THE LED WITH 250 OHM RESISTORS,LED IS DRIVEN WITH 5V VOLTAGE AND THE MAX OPERATING CURRENT IS 20mA.
 LED COLOR: DOMINANT WAVELENGTH (λD): GREEN 568 nm TYP @ VF=5V
 FORWARD CURRENT (IF): GREEN 12 mA TYP @ VF=5V
 DOMINANT WAVELENGTH (λD): YELLOW 588 nm TYP @ VF=5V
 FORWARD CURRENT (IF): YELLOW 13 mA TYP @ VF=5V

△ INDICATED CONNECTIONS ARE FOR NIC CONFIGURATION. THE MAGNETICS ARE SYMMETRIC, AND SUPPORT AUTO-MDI/MDIX.

△ TRP CONNECTOR LOGO, PART NUMBER, DATE CODE, COUNTRY OF ORIGIN AND AGENCY APPROVAL MARKING IN APPROXIMATE LOCATION SHOWN.

8. THESE PARTS ARE RECOMMENDED FOR WAVE SOLDERING PROCESS, PREHEAT TEMPERATURE IS 120°C TO 160°C, 120 SECONDS TO 180 SECONDS, PEAK SOLDERING TEMPERATURE IS 260 °C MAX, 10 SECONDS MAX.

YES	YELLOW	NO	GREEN	NO	5-6605704-9
NO	GREEN	YES	YELLOW	YES	6605704-1
2KV DECOUPLING CAPACITOR	LED1 △	250 OHMS RESISTOR △	LED2	250 OHMS RESISTOR △	PART NUMBER

THIS DRAWING IS A CONTROLLED DOCUMENT:		T. VARELA - DESIGN ENGINEER		DONGGUAN CHINA	
DIMENSIONS: INCHES		D. FARELO - DRAWING		DATE: 1X1 406ET 10/100 TAB UP W/ LED	
DIMENSIONS: MILLIMETERS		D. FARELO - DRAWING		SCALE: NTS	
DIMENSIONS: MILLIMETERS		MAGJACK		SHEET NO: 1	
DIMENSIONS: MILLIMETERS		SINGLE NON-POE		DRAWING NO: C-6605704	
DIMENSIONS: MILLIMETERS		APPLICATION SPEC:		RESTRICTED TO: -	
PRODUCT SPEC: 108-2100		CUSTOMER DRAWING		REV: F	