



Chipsmall Limited consists of a professional team with an average of over 10 year of expertise in the distribution of electronic components. Based in Hongkong, we have already established firm and mutual-benefit business relationships with customers from,Europe,America and south Asia,supplying obsolete and hard-to-find components to meet their specific needs.

With the principle of “Quality Parts,Customers Priority,Honest Operation,and Considerate Service”,our business mainly focus on the distribution of electronic components. Line cards we deal with include Microchip,ALPS,ROHM,Xilinx,Pulse,ON,Everlight and Freescale. Main products comprise IC,Modules,Potentiometer,IC Socket,Relay,Connector.Our parts cover such applications as commercial,industrial, and automotives areas.

We are looking forward to setting up business relationship with you and hope to provide you with the best service and solution. Let us make a better world for our industry!



Contact us

Tel: +86-755-8981 8866 Fax: +86-755-8427 6832

Email & Skype: info@chipsmall.com Web: www.chipsmall.com

Address: A1208, Overseas Decoration Building, #122 Zhenhua RD., Futian, Shenzhen, China



THIS DRAWING AND THE SUBJECT MATTER SHOWN THEREON ARE CONFIDENTIAL AND THE PROPERTY OF BEL/STEWART/TRP CONNECTOR AND SHALL NOT BE REPRODUCED, COPIED, OR USED IN ANY MANNER WITHOUT THE WRITTEN CONSENT OF TRP CONNECTOR.

PRODUCT MAY BE PROTECTED BY ONE OR MORE OF THE FOLLOWING US PATENTS:
 5736910 5939955 6425781 6428361 6554638 6840817 7123117
 7429195 7717749 7808751 6217391 6149050 7924130

REVISIONS				
P	REV	DESCRIPTION	DATE	APVD
G		EC-1411035 COMPANY LOGO CHANGE	05JAN2015	HY KZ

MECHANICAL:

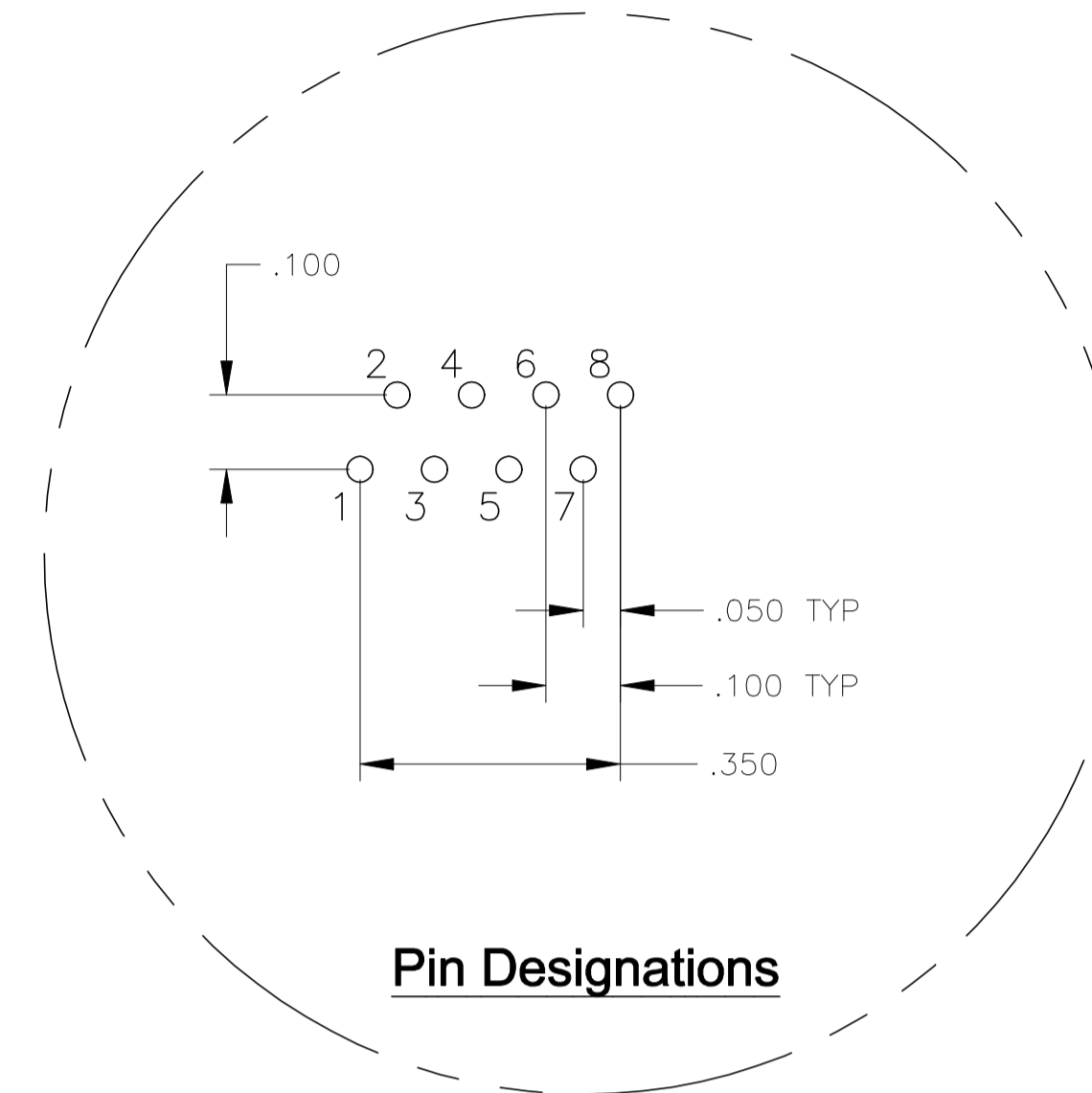
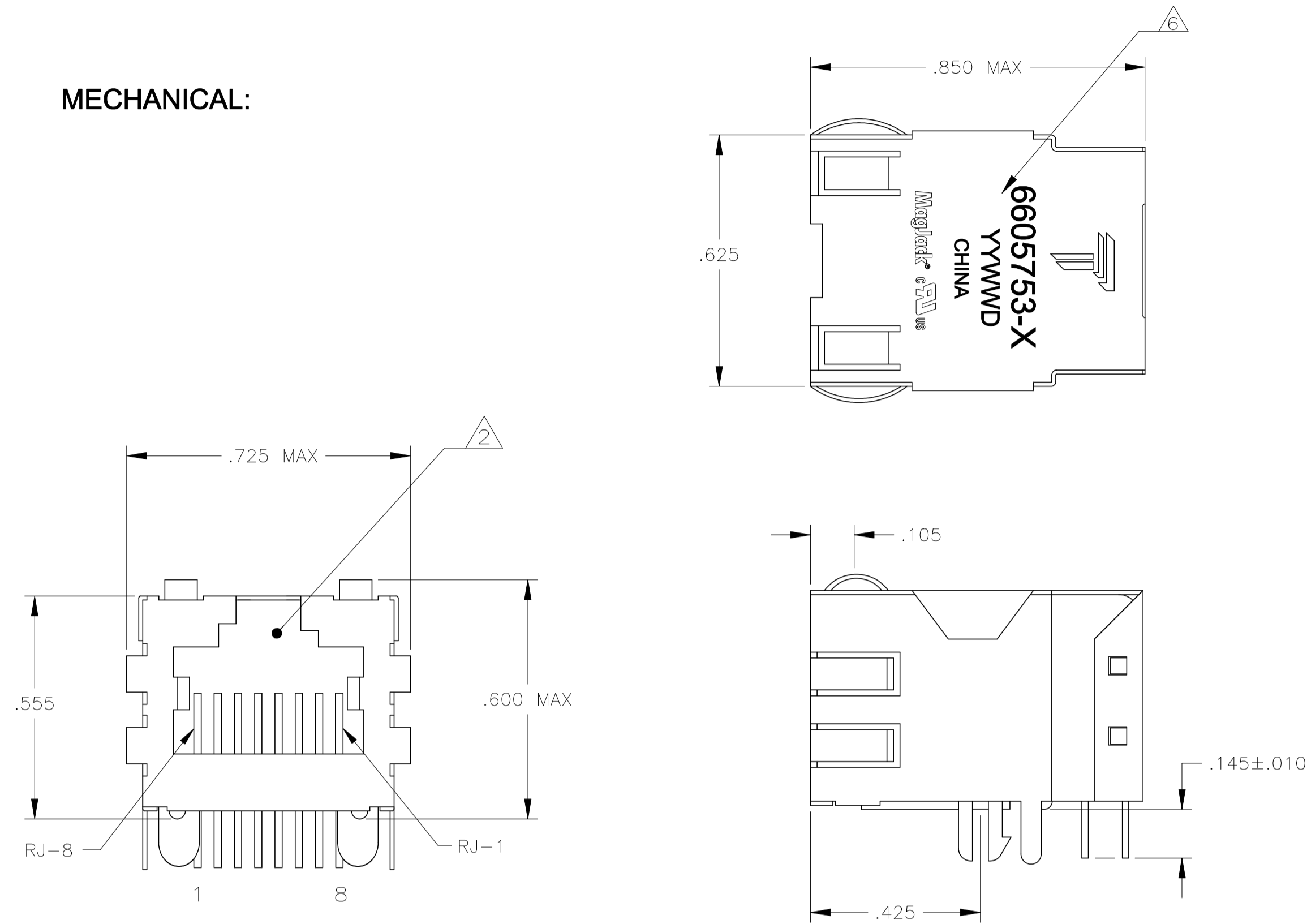

- MATERIALS:**
- HOUSING - THERMOPLASTIC PET POLYESTER FLAMMABILITY RATING UL 94V-0.
 - SHIELD - .010" THICK, C26800 BRASS PREPLATED WITH 30μINCH MIN SEMI-BRIGHT NICKEL, SOLDER TABS POST DIPPED WITH 100μINCH MIN SAC SOLDER.
 - MOD JACK CONTACTS - 0.0157" x 0.018" PHOSPHOR BRONZE, 50μINCH MIN OVERALL NICKEL UNDERPLATE, WITH SELECT 50μINCH MIN HARD GOLD FINISH PLATE. SOLDER TAILS WITH 100μINCH MIN MATTE TIN AND/OR SAC SOLDER DIP.
- MAGNETICS**
- APPLICATION: 10 BASE-T
 - IMPEDANCE: 100 OHMS
 - TURNS RATIO (CHIP:CABLE): TX = 1:2.5 RX = 1:1
 - TRANSMIT OPEN CIRCUIT INDUCTANCE (OCL): 14.0μH MIN @ 100kHz, 0.1VRMS
 - LEAKAGE INDUCTANCE (LL): 0.30μH MAX @ 100kHz, 0.1VRMS
 - INTERWINDING CAPACITANCE (CwW): 15pF MAX @ 100kHz, 0.1VRMS
 - ISOLATION VOLTAGE: 2250VDC (MAX) FOR 60 SECONDS WITH A RISE TIME OF 500V/SEC.
4. OPERATING TEMPERATURE: FROM 0°C TO +70°C.
- INDICATED CONNECTIONS ARE FOR NIC CONFIGURATION.
- TRP CONNECTOR LOGO, PART NUMBER, DATE CODE, COUNTRY OF ORIGIN AND AGENCY APPROVAL MARKING IN APPROXIMATE LOCATION SHOWN.
7. THE PART IS RECOMMENDED FOR WAVE SOLDERING PROCESS, PREHEAT TEMPERATURE IS 120°C TO 160°C, 120 SECONDS TO 180 SECONDS, PEAK WAVE SOLDERING TEMPERATURE IS 260°C MAX, 10 SECONDS MAX.

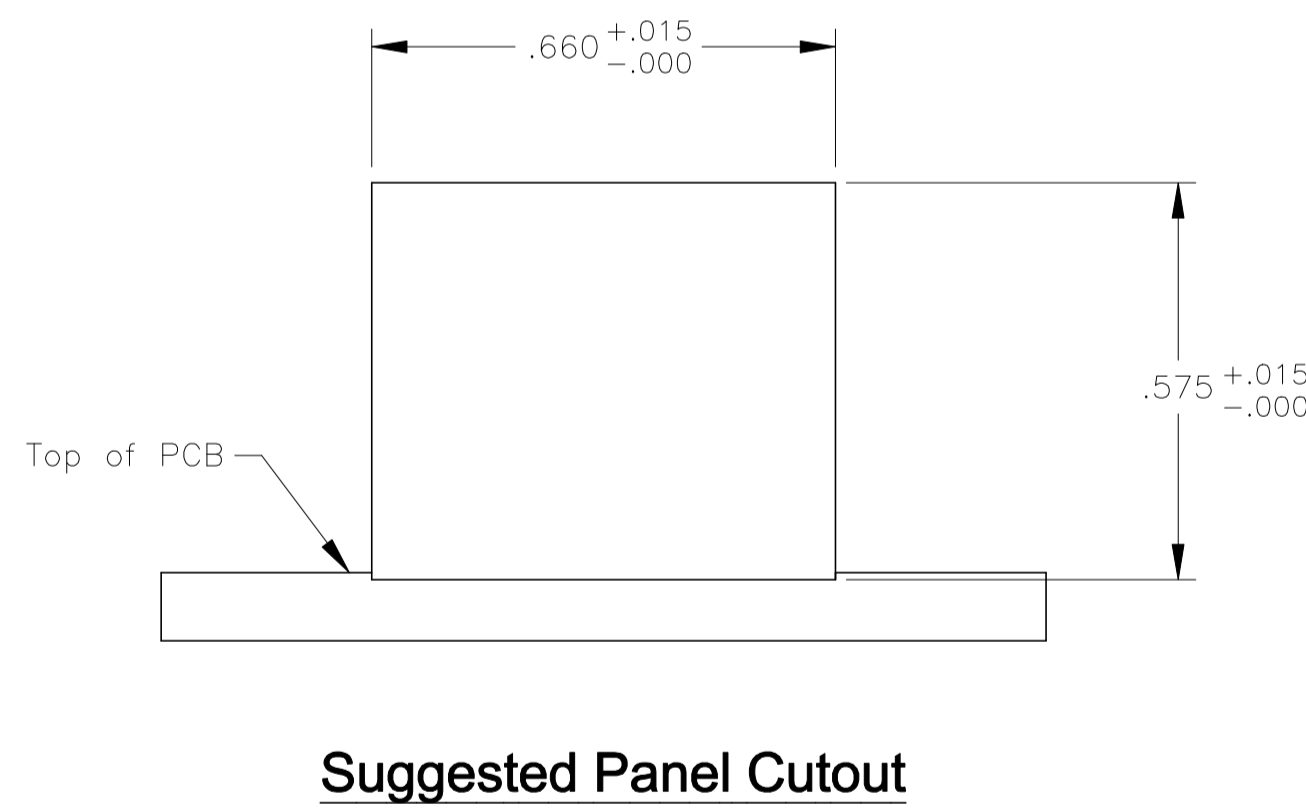

ELECTRICAL:

724 SERIES MAGNETIC CIRCUIT

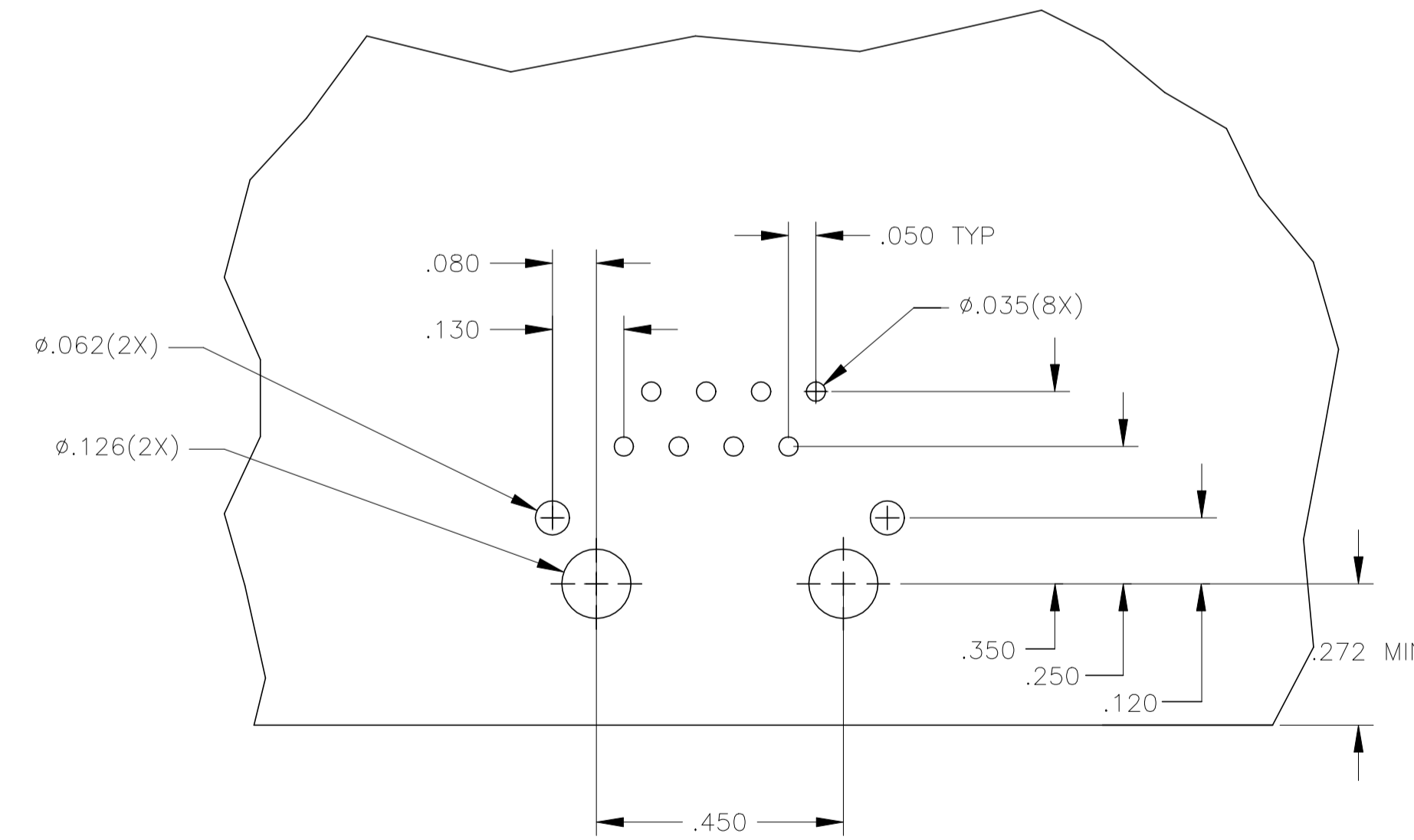
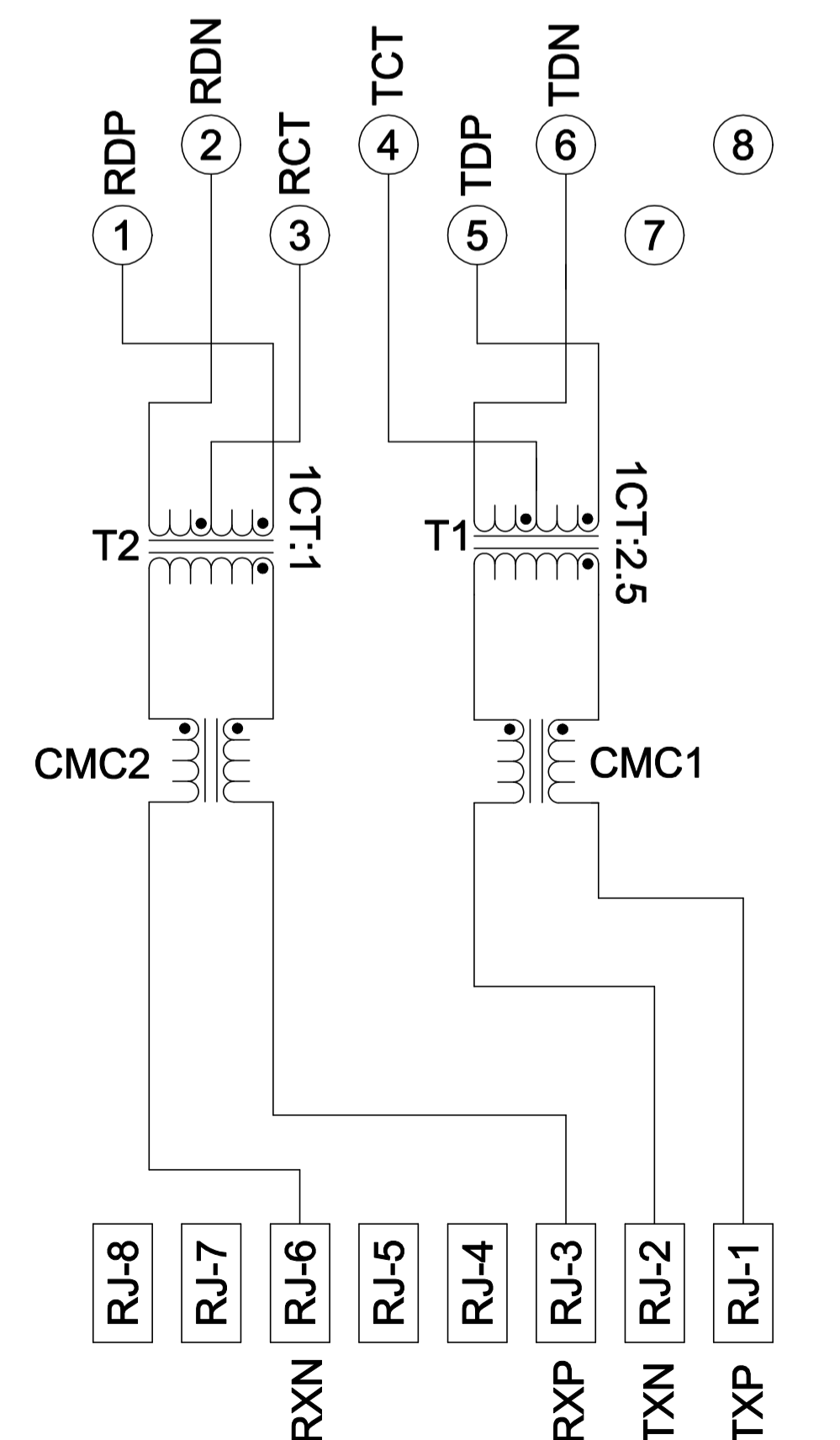

**Suggested PCB Layout
(Component Side)**

6605753-2
PART NUMBER

THIS DRAWING IS A CONTROLLED DOCUMENT.		DWN L. VARELA - DOCK5 28FEB2005	 trp CONNECTOR DONGGUAN CHINA
DIMENSIONS: INCHES		CHK D. FAROLE 28FEB2005	
0 PLC ± - 1 PLC ± - 2 PLC ± .010 3 PLC ± .005 4 PLC ± - ANGLES ± -		APVD D. FAROLE 28FEB2005	MODEL NAME DESC 1X1 724 10BASE-T TAB UP W/O LED
PRODUCT SPEC 108-2100	APPLICATION SPEC -		MAGJACK SINGLE NON-POE SIZE: A1 CAGE CODE: - DRAWING NO: C-6605753 RESTRICTED TO: - CUSTOMER DRAWING
		SCALE NTS	SHEET 1 OF 1 REV G