



Chipsmall Limited consists of a professional team with an average of over 10 year of expertise in the distribution of electronic components. Based in Hongkong, we have already established firm and mutual-benefit business relationships with customers from,Europe,America and south Asia,supplying obsolete and hard-to-find components to meet their specific needs.

With the principle of “Quality Parts,Customers Priority,Honest Operation,and Considerate Service”,our business mainly focus on the distribution of electronic components. Line cards we deal with include Microchip,ALPS,ROHM,Xilinx,Pulse,ON,Everlight and Freescale. Main products comprise IC,Modules,Potentiometer,IC Socket,Relay,Connector.Our parts cover such applications as commercial,industrial, and automotives areas.

We are looking forward to setting up business relationship with you and hope to provide you with the best service and solution. Let us make a better world for our industry!



Contact us

Tel: +86-755-8981 8866 Fax: +86-755-8427 6832

Email & Skype: info@chipsmall.com Web: www.chipsmall.com

Address: A1208, Overseas Decoration Building, #122 Zhenhua RD., Futian, Shenzhen, China



THIS DRAWING AND THE SUBJECT MATTER SHOWN THEREON ARE CONFIDENTIAL AND THE PROPERTY OF BEL/STEWART/TRP CONNECTOR AND SHALL NOT BE REPRODUCED, COPIED, OR USED IN ANY MANNER WITHOUT THE WRITTEN CONSENT OF TRP CONNECTOR.

PRODUCT MAY BE PROTECTED BY ONE OR MORE OF THE FOLLOWING US PATENTS:
 5736910 5939955 6425781 6428361 6554638 6840817 7123117
 7429195 7717749 7808751 6217391 6149050 7924130

REVISIONS				
P	LYR	DESCRIPTION	DATE	APVD
E		EC-1411035 COMPANY LOGO CHANGE	09JAN2015	HY KZ

MECHANICAL:

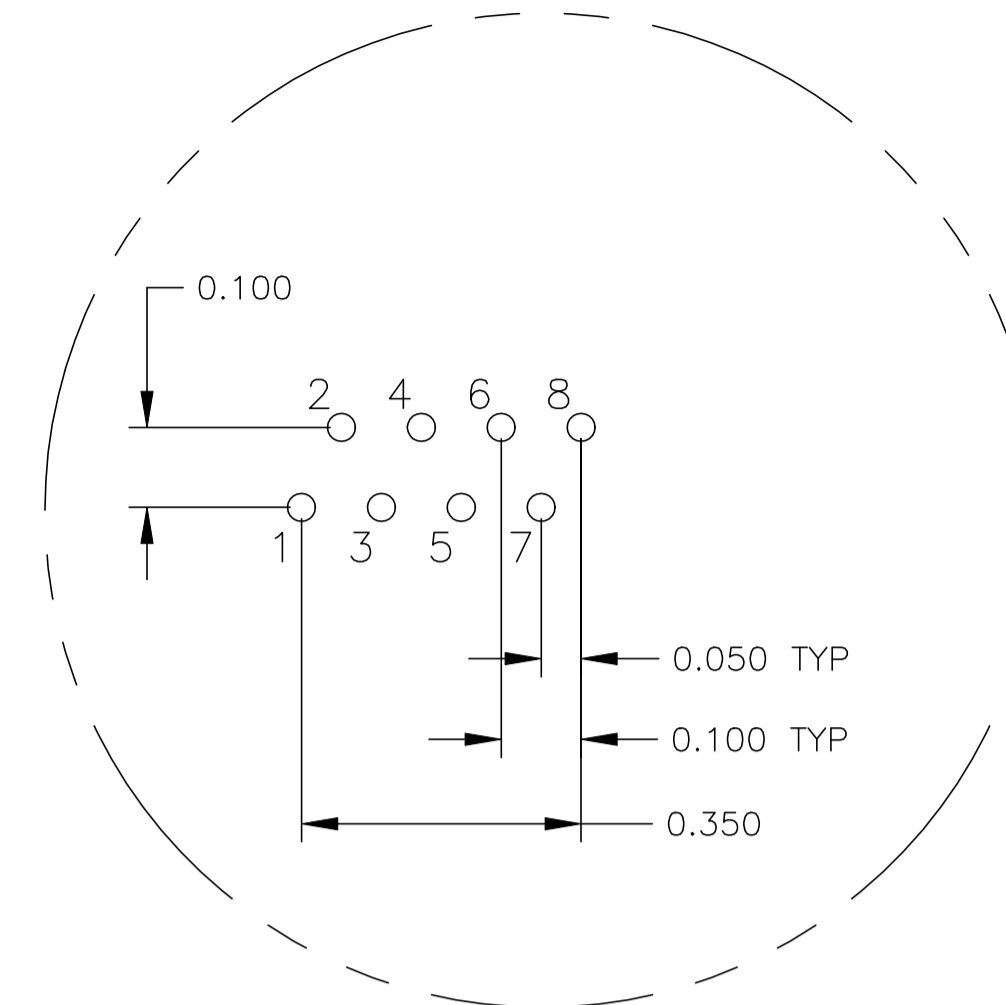
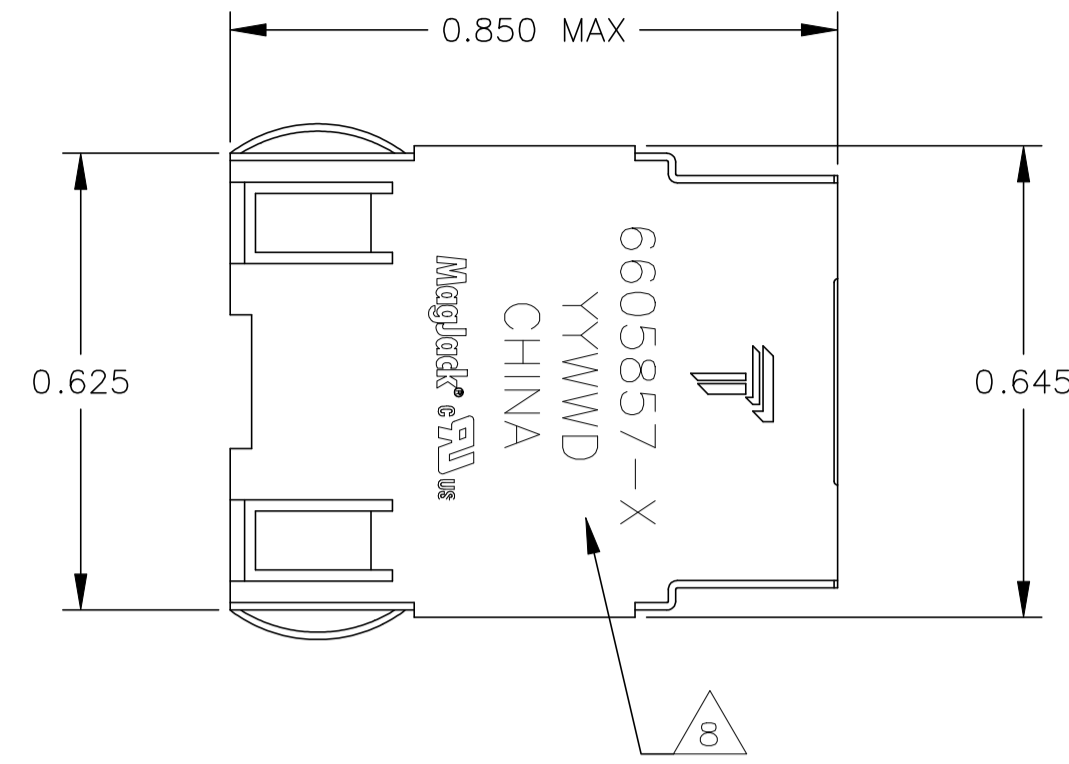

Pin Designations

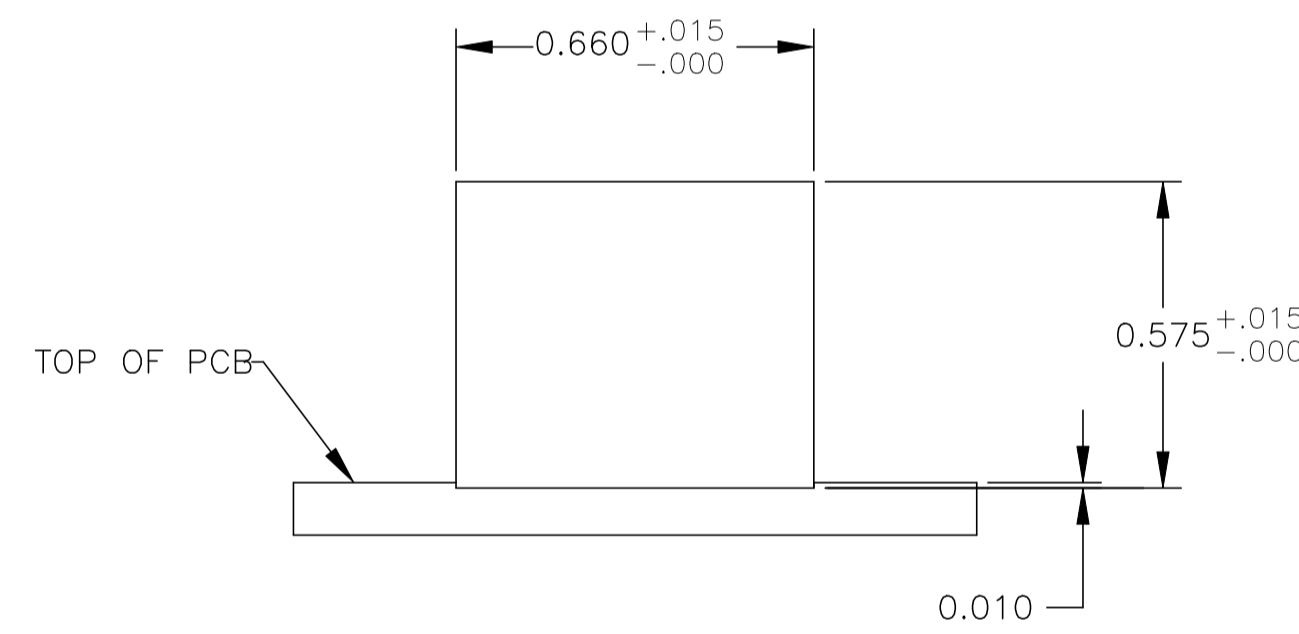
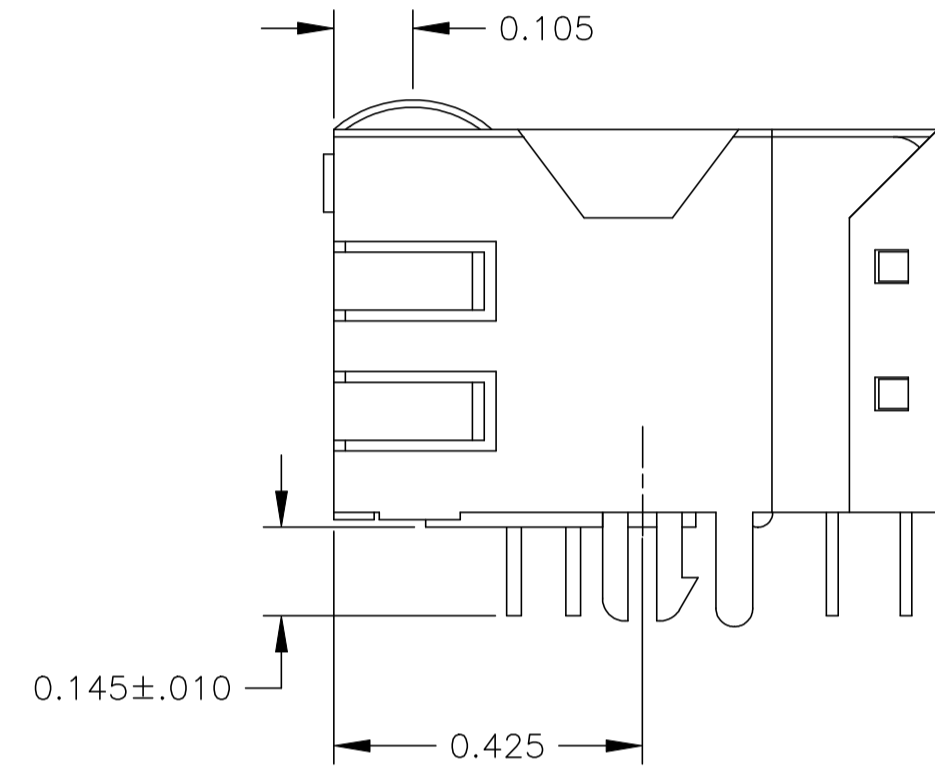
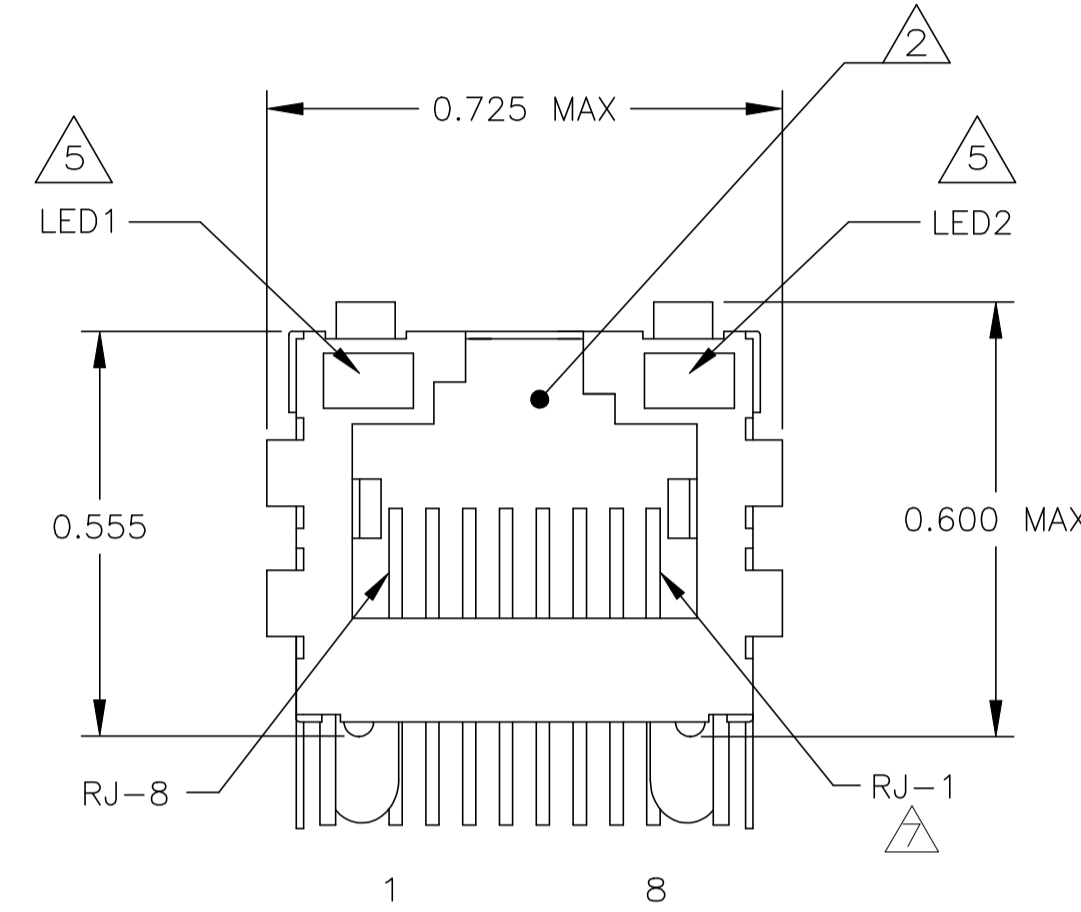

Suggested Panel Cutout

720 SERIES MAGNETIC CIRCUIT

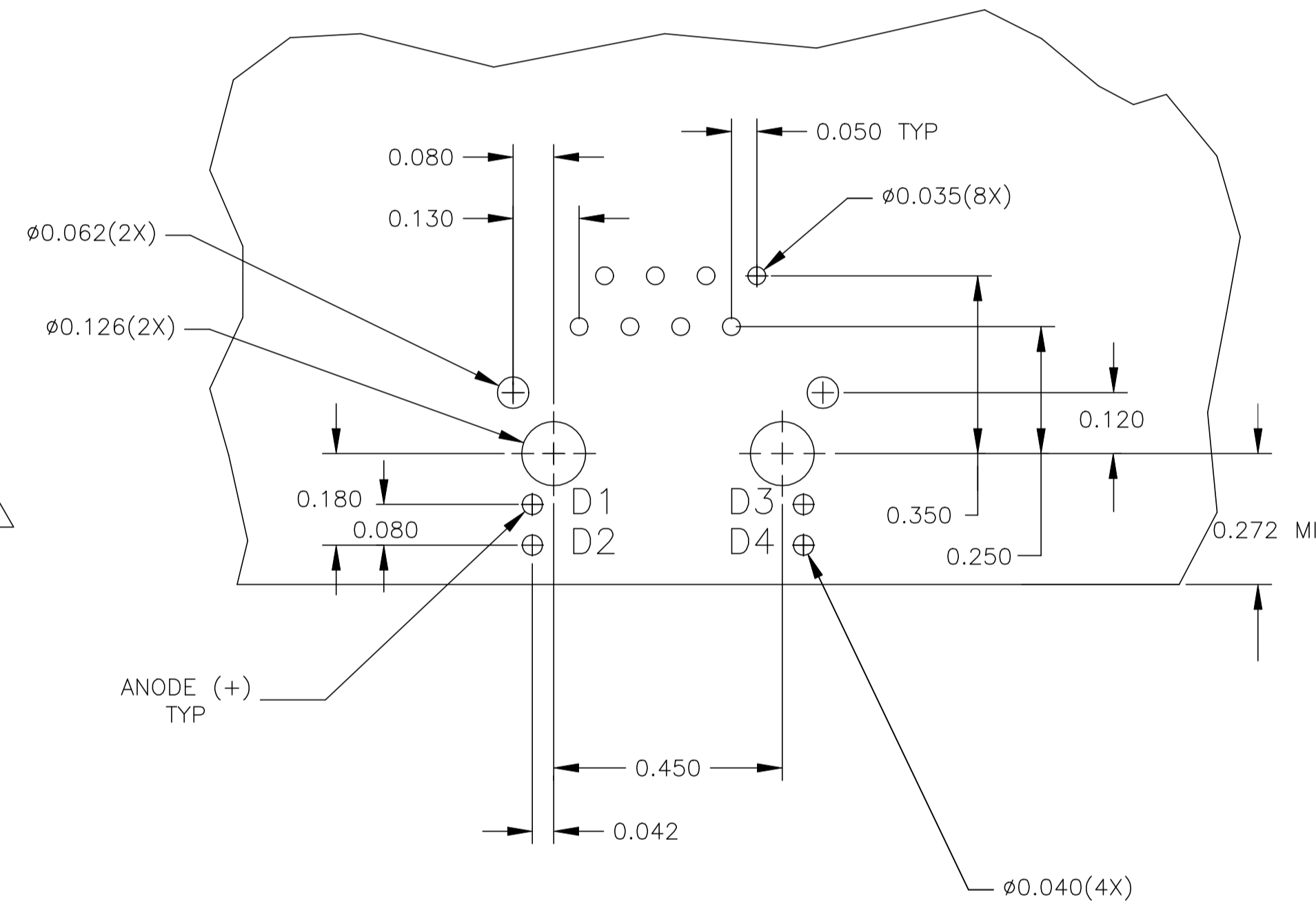
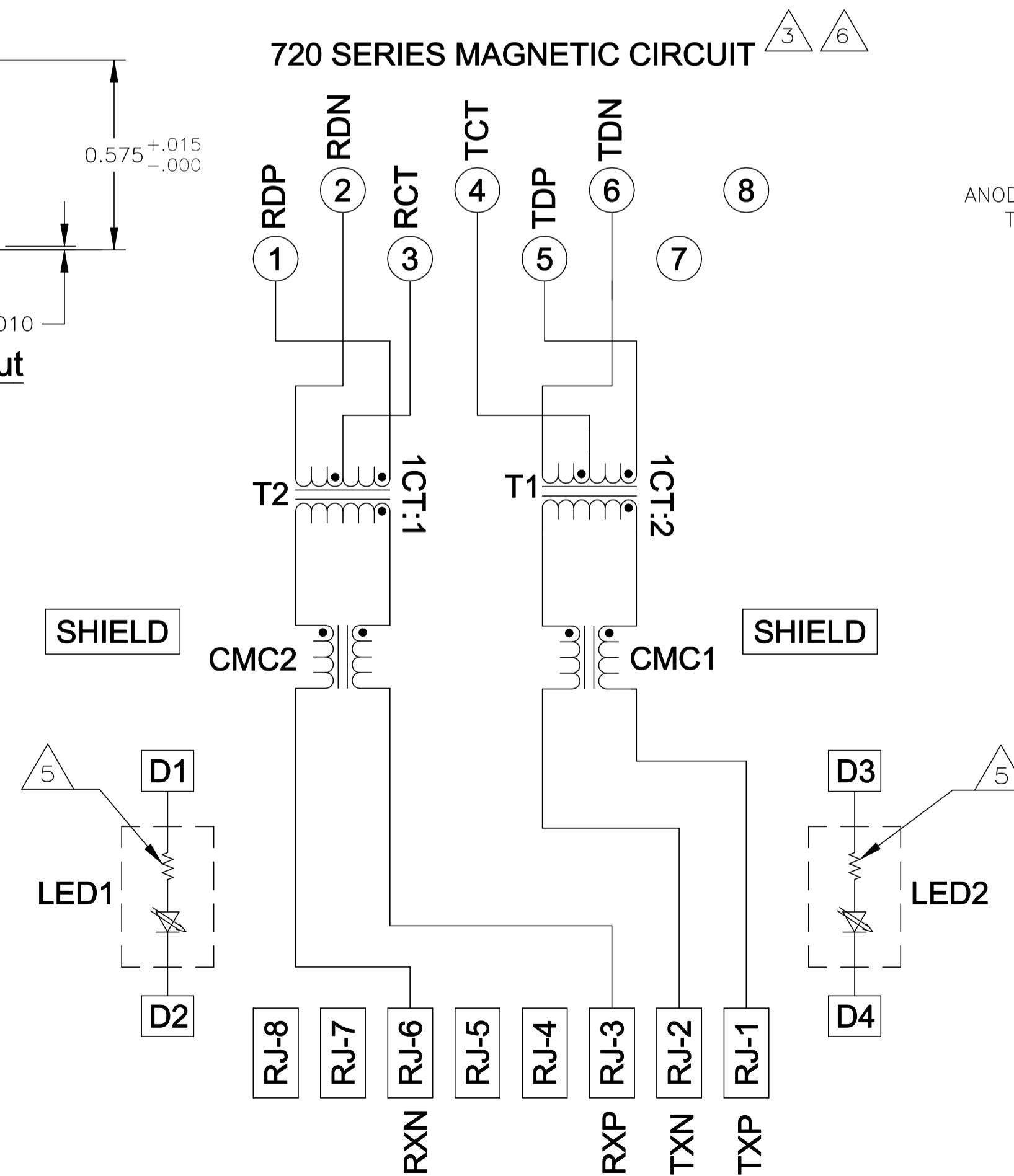

Suggested PCB Layout (Component Side)

- △ MATERIALS:
 - HOUSING - THERMOPLASTIC PET POLYESTER FLAMMABILITY RATING UL 94V-0.
 - SHIELD - .010" THICK, C26800 BRASS PREPLATED WITH 30μINCH MIN SEMI-BRIGHT NICKEL, SOLDER TABS POST DIPPED WITH 100μINCH MIN SAC SOLDER.
 - MOD JACK CONTACTS - 0.0157" x 0.018" PHOSPHOR BRONZE, 50μINCH MIN OVERALL NICKEL UNDERPLATE, WITH SELECT 50μINCH MIN HARD GOLD FINISH PLATE.
 - SOLDERTAILS WITH 100μINCH MIN MATTE TIN AND/OR SAC SOLDER DIP.
 - LIGHT EMITTING DIODE(LED) - DIFFUSED EPOXY LENS, .020" x .020" CARBON STEEL.
 - WIREFRAME LEADS PRE-PLATED WITH 80μINCH SILVER OVER 40μINCH NICKEL UNDERPLATE OVER 40μINCH COPPER UNDERPLATE, POST-PLATED WITH 100μINCH MIN MATTE TIN AND/OR SAC SOLDER DIP OR PURE TIN SOLDER DIP.

- △ RJ45 JACK CAVITY CONFORMS TO FCC RULES AND REGULATIONS PART 68, SUB PART F.

- △ MAGNETICS
 - APPLICATION: 10 BASE-T
 - IMPEDANCE: 100 OHMS
 - TURNS RATIO (CHIP:CABLE): TX = 1:2 RX = 1:1
 - TRANSMIT OPEN CIRCUIT INDUCTANCE (OCL): 140μH MIN @ 100kHz, 0.1VRMS
 - LEAKAGE INDUCTANCE (LL): 0.40μH MAX @ 100kHz, 0.1VRMS
 - INTERWINDING CAPACITANCE (CWW): 12pF MAX @ 100kHz, 0.1VRMS
 - ISOLATION VOLTAGE:2250VDC (MAX) FOR 60 SECONDS WITH A RISE TIME OF 500V/SEC.

- 4. OPERATING TEMPERATURE: FROM 0°C TO +70°C

- △ THE LED WITH 250 OHM RESISTORS,LED IS DRIVEN WITH 5V VOLTAGE AND THE MAX OPERATING CURRENT IS 20mA.
 LED COLOR:
 DOMINANT WAVELENGTH (λD): GREEN 568 nm TYP. At VF=5V
 FORWARD CURRENT (IF): GREEN 12 mA TYP. at VF=5V
 DOMINANT WAVELENGTH(λD):YELLOW 588nmTYP. At VF=5V
 FORWARD CURRENT (IF):YELLOW 13 mA TYP. at VF=5V

- △ INDICATED CONNECTIONS ARE FOR NIC CONFIGURATION.

- △ CONTACT LUBRICANT APPLIED IN MATING AREA.

- △ TRP CONNECTOR LOGO, PART NUMBER, DATE CODE, COUNTRY OF ORIGIN AND AGENCY APPROVAL MARKING IN APPROXIMATE LOCATION SHOWN.

- 9. THESE PARTS ARE RECOMMENDED FOR WAVE SOLDERING PROCESS, PREHEAT TEMPERATURE IS 120°C TO 160°C, 120 SECONDS TO 180 SECONDS, PEAK WAVE SOLDERING TEMPERATURE IS 260°C MAX, 10 SECONDS MAX.

GREEN	YELLOW	6605857-1
LED1	LED2	PART NUMBER

THIS DRAWING IS A CONTROLLED DOCUMENT.		DWN L. VARELA - DOCK5 CHK D. FAROLE APVD D. FAROLE		07MAR2005 07MAR2005 07MAR2005	
DIMENSIONS: INCHES		TOLERANCES UNLESS OTHERWISE SPECIFIED:		DONGGUAN CHINA	
0 PLC ± - 1 PLC ± - 2 PLC ± .010 3 PLC ± .005 4 PLC ± - ANGLES ± -		MODEL NAME MAGJACK SINGLE NON-POE		DESC 1X1 720 10/100 TAB UP W/ LED SIZE CAGE CODE DRAWING NO A1 C=6605857	
PRODUCT SPEC 108-2100		APPLICATION SPEC -		RESTRICTED TO CUSTOMER DRAWING SCALE NTS SHEET 1 OF 1 REV E	