



Chipsmall Limited consists of a professional team with an average of over 10 year of expertise in the distribution of electronic components. Based in Hongkong, we have already established firm and mutual-benefit business relationships with customers from,Europe,America and south Asia,supplying obsolete and hard-to-find components to meet their specific needs.

With the principle of “Quality Parts,Customers Priority,Honest Operation,and Considerate Service”,our business mainly focus on the distribution of electronic components. Line cards we deal with include Microchip,ALPS,ROHM,Xilinx,Pulse,ON,Everlight and Freescale. Main products comprise IC,Modules,Potentiometer,IC Socket,Relay,Connector.Our parts cover such applications as commercial,industrial, and automotives areas.

We are looking forward to setting up business relationship with you and hope to provide you with the best service and solution. Let us make a better world for our industry!



Contact us

Tel: +86-755-8981 8866 Fax: +86-755-8427 6832

Email & Skype: info@chipsmall.com Web: www.chipsmall.com

Address: A1208, Overseas Decoration Building, #122 Zhenhua RD., Futian, Shenzhen, China



THIS DRAWING AND THE SUBJECT MATTER SHOWN THEREON ARE CONFIDENTIAL AND THE PROPERTY OF BEL/STEWART/TRP CONNECTOR AND SHALL NOT BE REPRODUCED, COPIED, OR USED IN ANY MANNER WITHOUT THE WRITTEN CONSENT OF TRP CONNECTOR.

PRODUCT MAY BE PROTECTED BY ONE OR MORE OF THE FOLLOWING US PATENTS:
 5736910 5939955 6425781 6428361 6554638 6840817 7123117
 7429195 7717749 7808751 6217391 6149050 7924130

REVISIONS				
P	LYR	DESCRIPTION	DATE	APVD
E		EC-1411035 COMPANY LOGO CHANGE	07JAN2015	DZ TL

MECHANICAL:

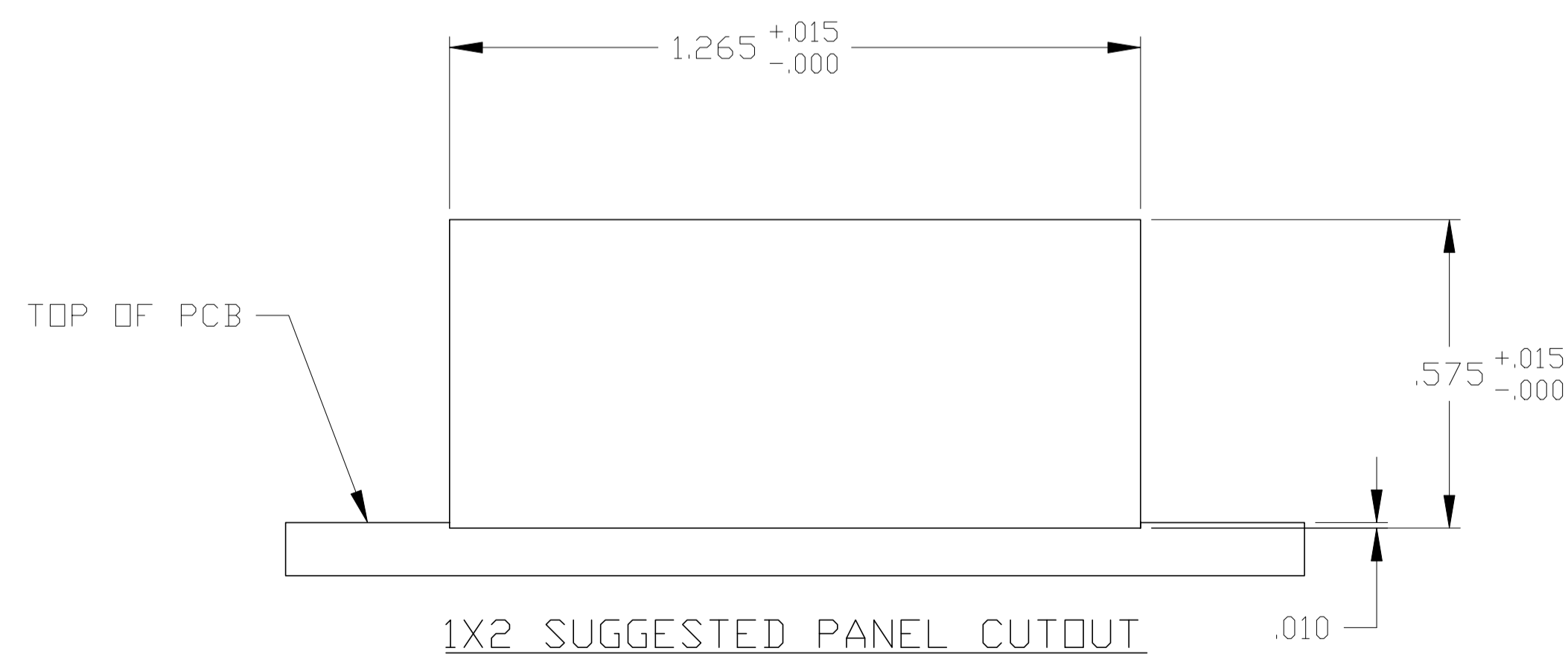
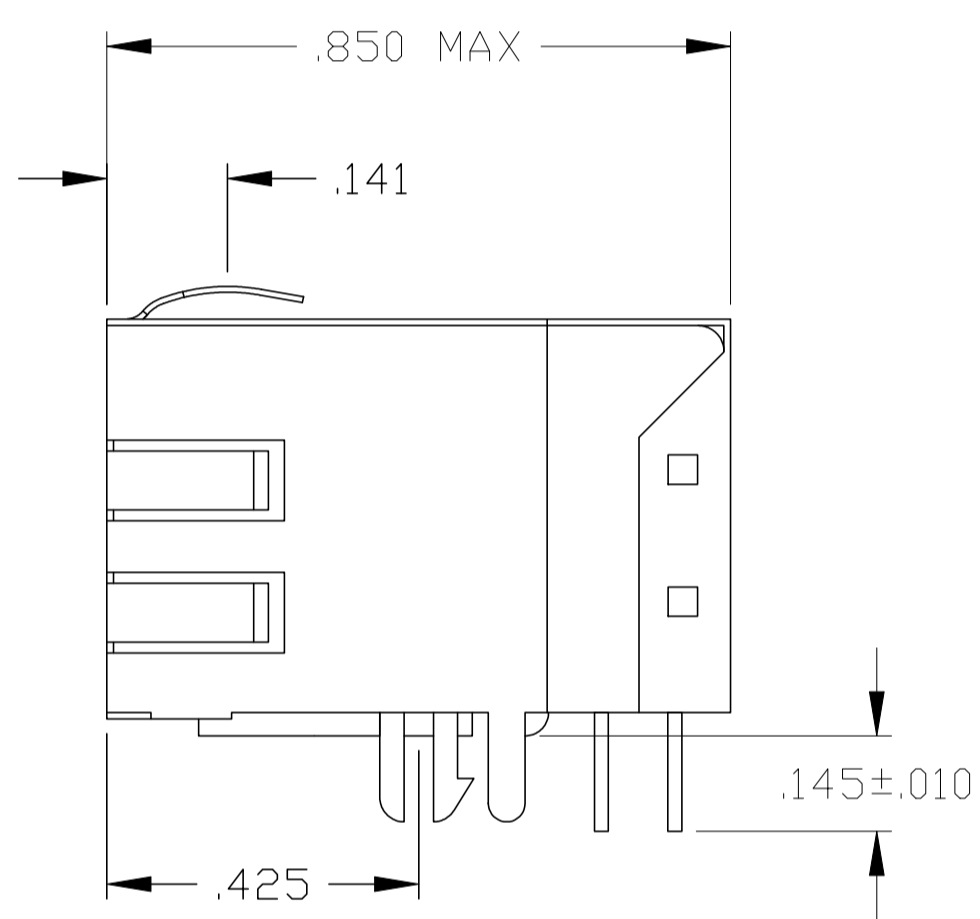
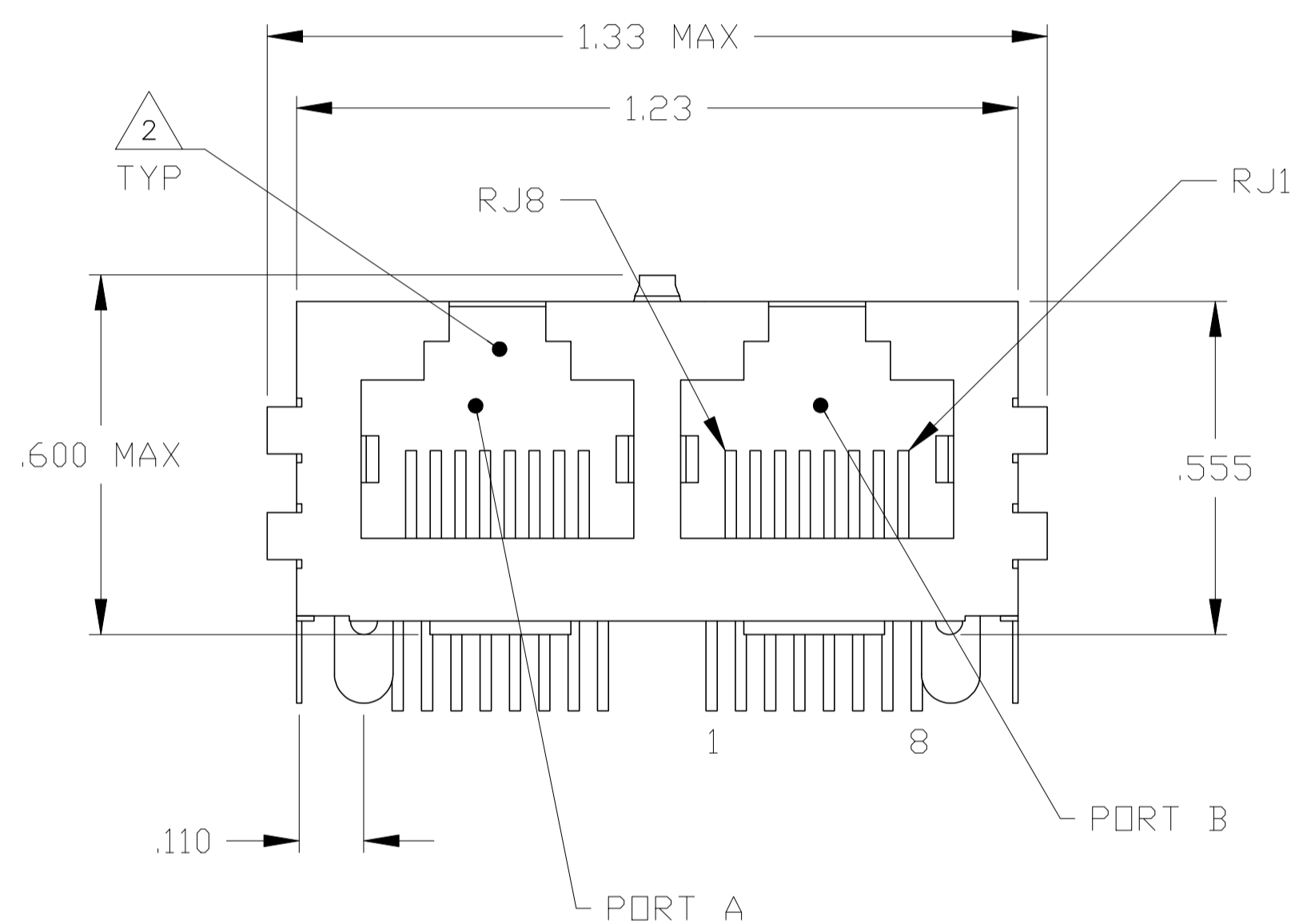
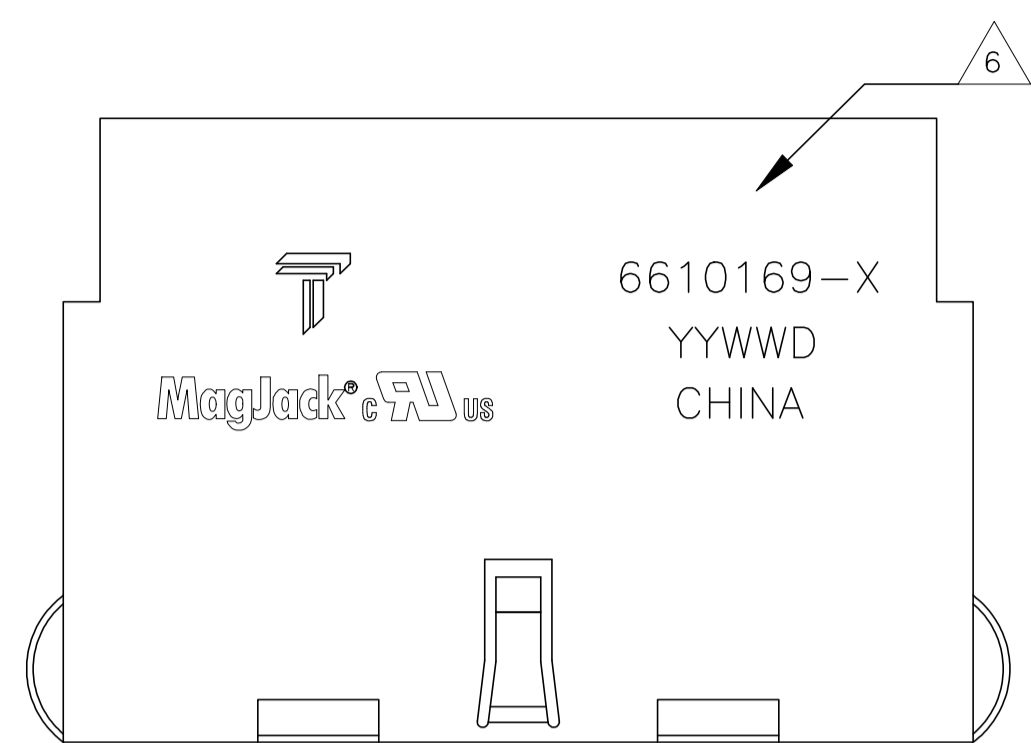

- 1 MATERIALS:
 -HOUSING - THERMOPLASTIC PET POLYESTER FLAMMABILITY RATING UL 94 V-0.
 -SHIELD - .010" THICK, C26800 BRASS PREPLATED WITH 30μINCH MIN SEMI-BRIGHT NICKEL. SOLDER TABS POST DIPPED WITH 100μINCH MIN SAC SOLDER.
 -MOD JACK CONTACTS - 0.0157 X 0.018" PHOSPHOR BRONZE, 50μINCH MIN OVERALL NICKEL UNDERPLATE WITH SELECT 50μINCH MIN HARD GOLD FINISH PLATE. SOLDER TAILS WITH 100μINCH MIN MATTE TIN AND/OR SAC SOLDER DIP.
- 2 RJ45 JACK CAVITY CONFORMS TO FCC RULES AND REGULATIONS PART 68, SUB PART F.
- 3 MAGNETICS
 -IMPEDANCE: 100 OHMS
 -TURNS RATIO (CHIP:CABLE): TX = 1:1, RX = 1:1
 -OPEN CIRCUIT INDUCTANCE (OCL): 350μH MIN @100kHz, 0.1VRMS, 8mADC BIAS FROM 0°C TO 70°C, TX AND RX
 -PERFORMANCE @ 25°C:
 INSERTION LOSS (IL): 1.1dB MAX FROM 0.5MHz TO 100MHz
 RETURN LOSS (RL): 18dB MIN FROM 0.5MHz TO 30MHz
 18-20LOG(f/30)dB MIN FROM 30.1MHz TO 60MHz
 12dB MIN FROM 60.1MHz TO 80MHz
 CROSSTALK ATTENUATION: 35dB MIN FROM 0.5MHz TO 40MHz
 33-20*LOG(f/50)dB MIN FROM 40.1MHz TO 100MHz
 COMMON MODE REJECTION RATIO (CMRR): 30dB MIN FROM 0.5MHz TO 100MHz
 -ISOLATION VOLTAGE: COMPLIES WITH IEEE802.3 2002, PARA 23.5.1.1, ITEM b.
- 4 OPERATING TEMPERATURE: FROM 0°C TO +70°C.
- 5 INDICATED CONNECTIONS ARE FOR HUB CONFIGURATION. THE MAGNETICS ARE SYMMETRICAL AND ACCOMODATE AUTO-MDI/MDIX.
- 6 TRP CONNECTOR LOGO, PART NUMBER, DATE CODE, COUNTRY OF ORIGIN AND AGENCY APPROVAL MARKING IN APPROXIMATE LOCATION SHOWN.
- 7 THESE PARTS ARE RECOMMENDED FOR WAVE SOLDERING PROCESS, PREHEAT TEMPERATURE IS 120°C TO 160°C, 120 SECONDS TO 180 SECONDS, PEAK WAVE SOLDERING TEMPERATURE IS 260°C MAX, 10 SECONDS MAX.

6610169-1
PART NUMBER

THIS DRAWING IS A CONTROLLED DOCUMENT.		DWN G. ATTADIA - DOCK5 16MAR2005	16MAR2005		DONGGUAN CHINA
DIMENSIONS: INCHES		CHK D. FAROLE 16MAR2005	16MAR2005		
TOLERANCES UNLESS OTHERWISE SPECIFIED: 0 PLC ± - 1 PLC ± - 2 PLC ± .010 3 PLC ± .005 4 PLC ± - ANGLES ± -		APVD D. FAROLE 16MAR2005	16MAR2005	MODEL NAME MAGJACK GANG NON-POE	
PRODUCT SPEC 108-2100	APPLICATION SPEC -	DESC 1X2 746 10/100 TAB UP W/O LED		SIZE A1	CAGE CODE DRAWING NO C-6610169
CUSTOMER DRAWING				SCALE NTS	SHEET 1 OF 2 REV E

746 SERIES MAGNETIC CIRCUIT 

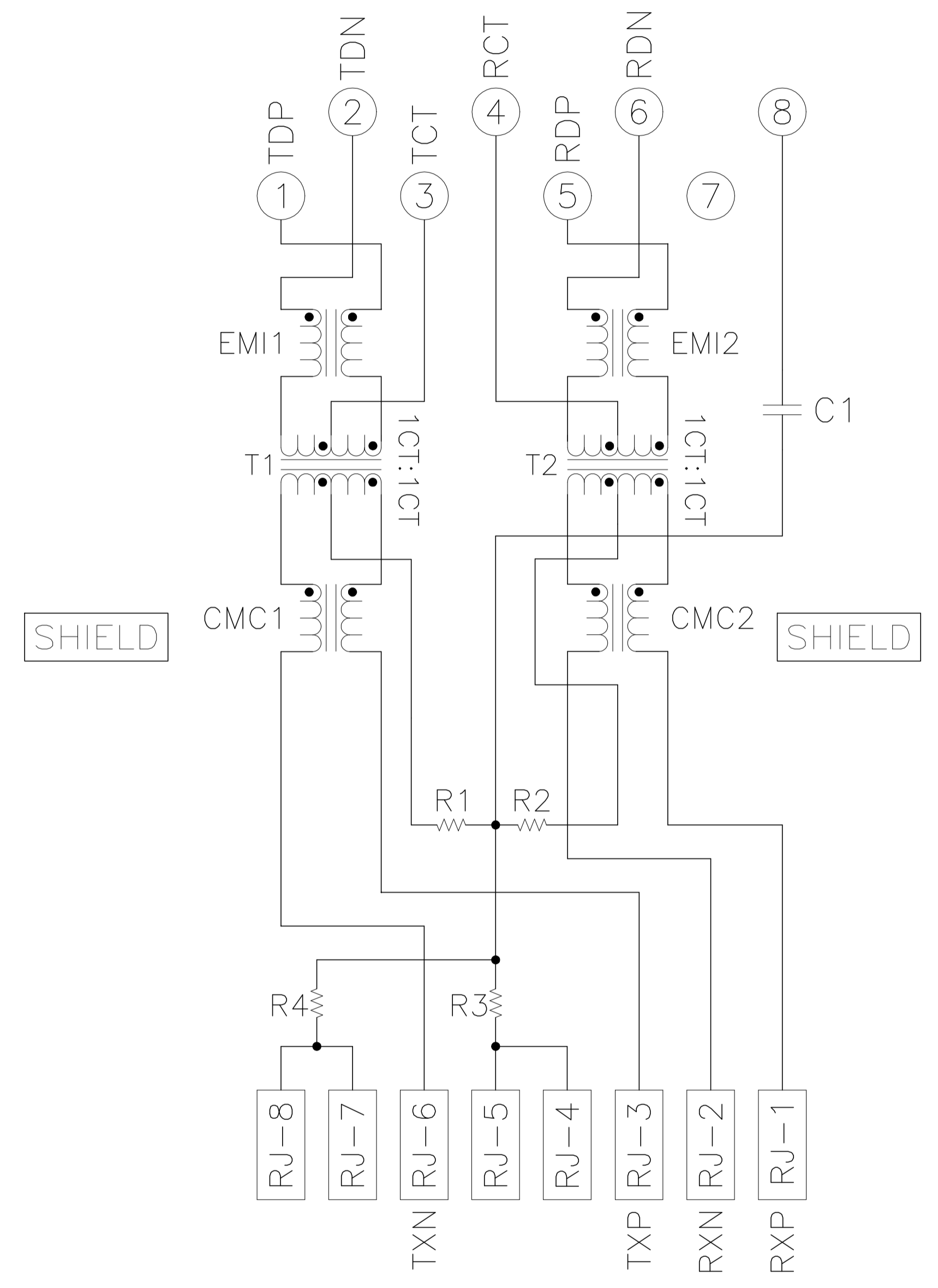

C1 = 1000pF, 2kV DECOUPLING CAPACITOR
 R1-R4 = 75 OHMS, 1/16W RESISTORS

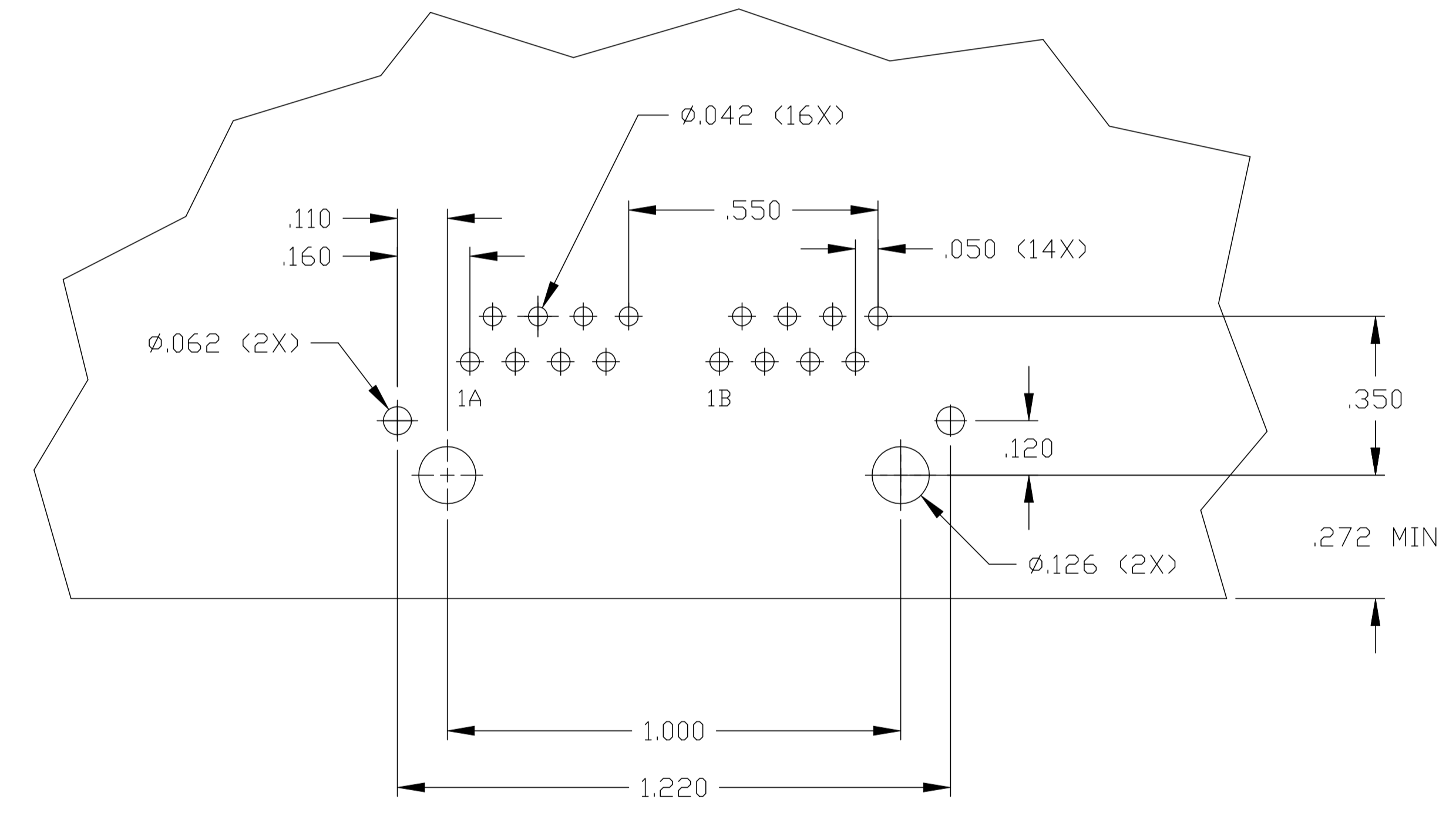
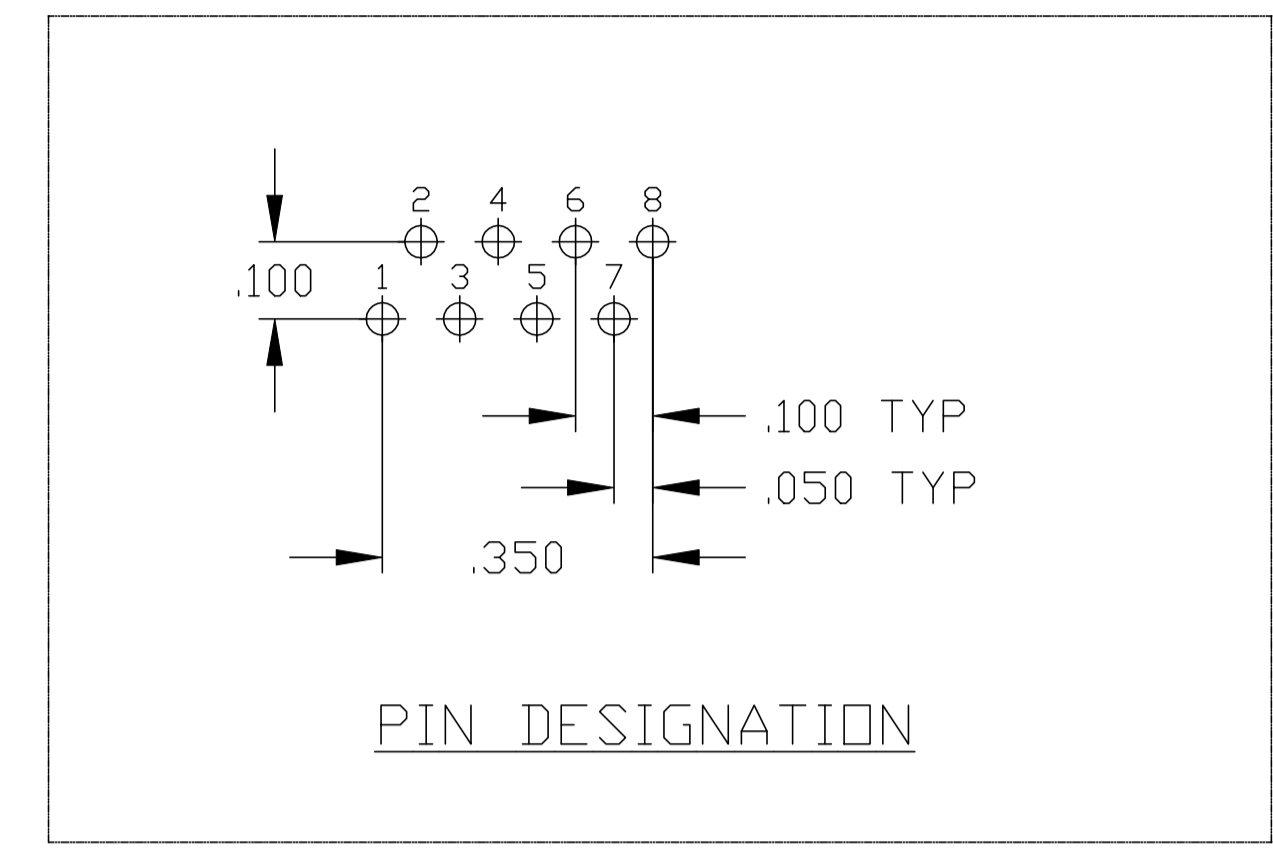

SUGGESTED PCB LAYOUT
 (Component Side)

THIS DRAWING IS A CONTROLLED DOCUMENT.		DWN G. ATTADIA - DOCK5 CHK D. FAROLE APVD D. FAROLE 16MAR2005 16MAR2005		 DONGGUAN CHINA	
DIMENSIONS: INCHES 0 PLC ± - 1 PLC ± - 2 PLC ± .010 3 PLC ± .005 4 PLC ± - ANGLES ± - APPLICATION SPEC -		MODEL NAME MAGJACK GANG NON-POE		DESC 1X2 746 10/100 TAB UP W/O LED	
PRODUCT SPEC 108-2100		SIZE A1		CAGE CODE C-6610169	
CUSTOMER DRAWING		SCALE NTS		SHEET 2 OF 2	
				REV E	