



Chipsmall Limited consists of a professional team with an average of over 10 year of expertise in the distribution of electronic components. Based in Hongkong, we have already established firm and mutual-benefit business relationships with customers from,Europe,America and south Asia,supplying obsolete and hard-to-find components to meet their specific needs.

With the principle of “Quality Parts,Customers Priority,Honest Operation,and Considerate Service”,our business mainly focus on the distribution of electronic components. Line cards we deal with include Microchip,ALPS,ROHM,Xilinx,Pulse,ON,Everlight and Freescale. Main products comprise IC,Modules,Potentiometer,IC Socket,Relay,Connector.Our parts cover such applications as commercial,industrial, and automotives areas.

We are looking forward to setting up business relationship with you and hope to provide you with the best service and solution. Let us make a better world for our industry!



Contact us

Tel: +86-755-8981 8866 Fax: +86-755-8427 6832

Email & Skype: info@chipsmall.com Web: www.chipsmall.com

Address: A1208, Overseas Decoration Building, #122 Zhenhua RD., Futian, Shenzhen, China



LOC		DIST		REVISIONS					
AD	00	REV	PER	EC	DATE	BY	CHK		
		0	REV	PER	EC	0512-0309-04	19MAY05	BC	GS
		A	ECR	-10-	019054		15SEP10	DP	MQW

CONNECTOR ASSEMBLY EXAMPLARY LOADED

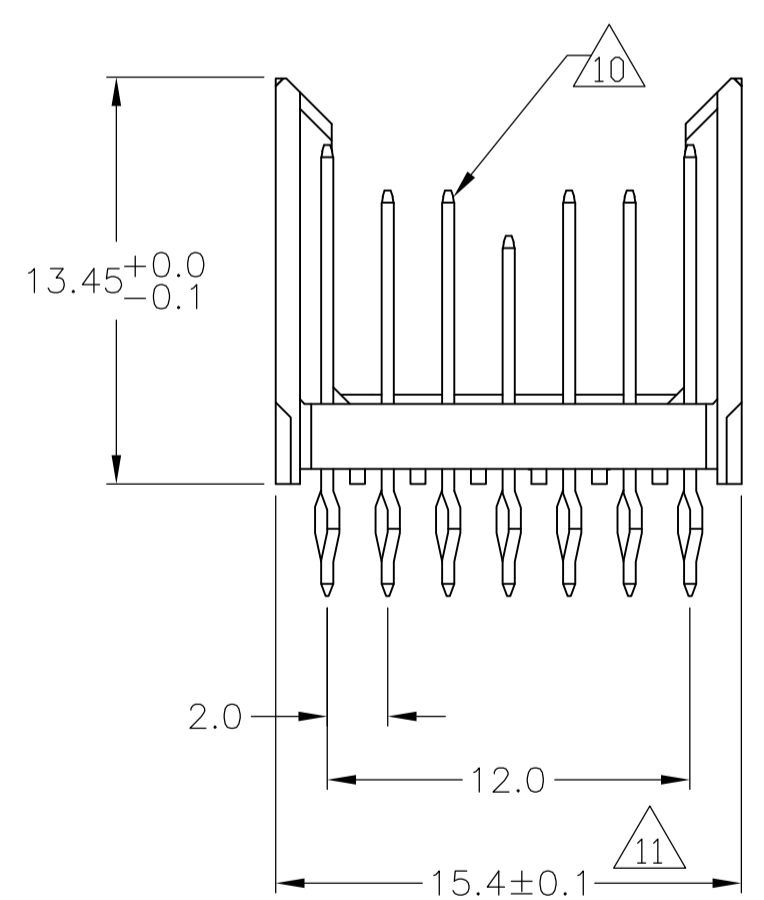
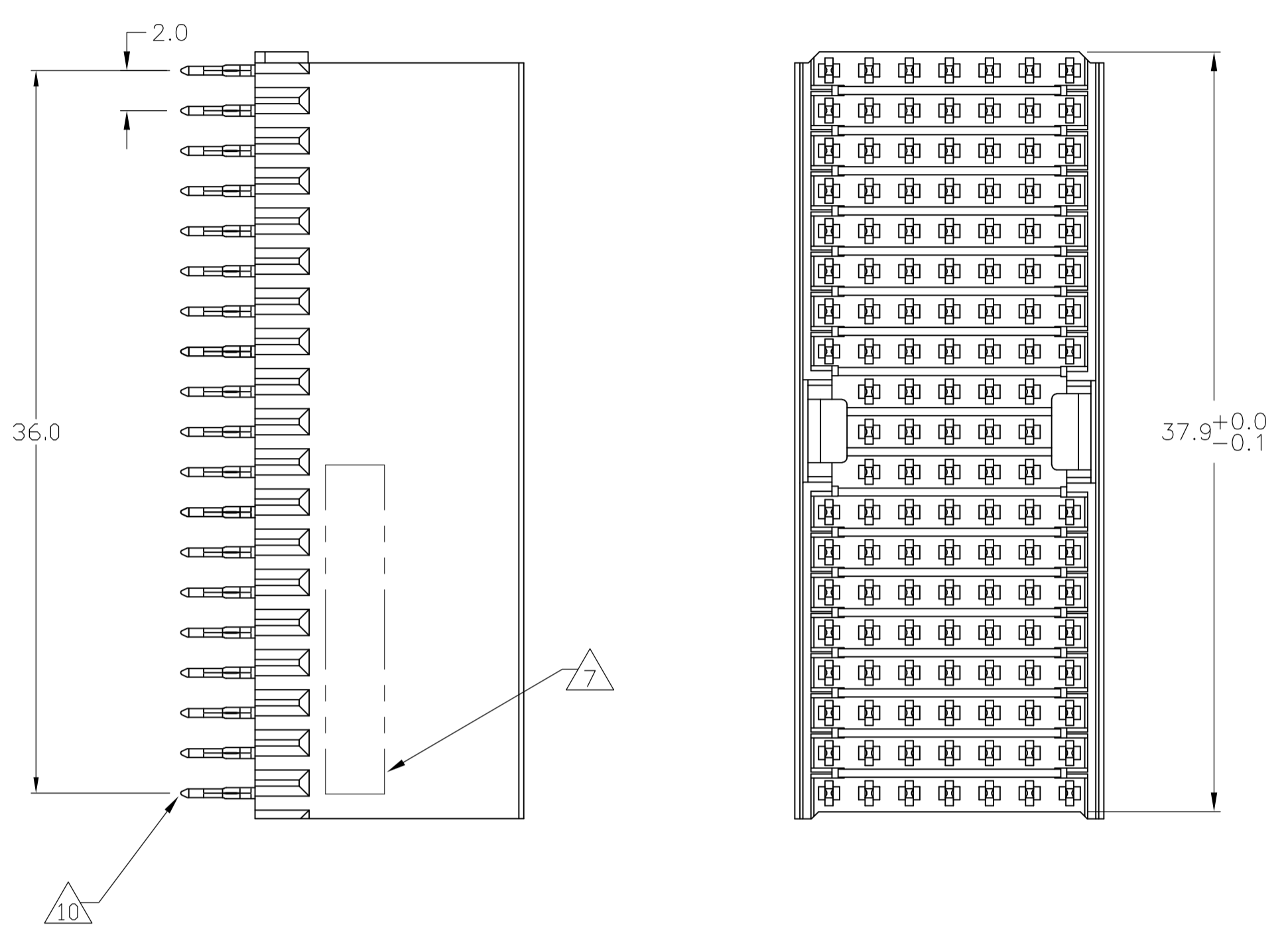

CONTACT DIMENSIONS SCALE 5:1

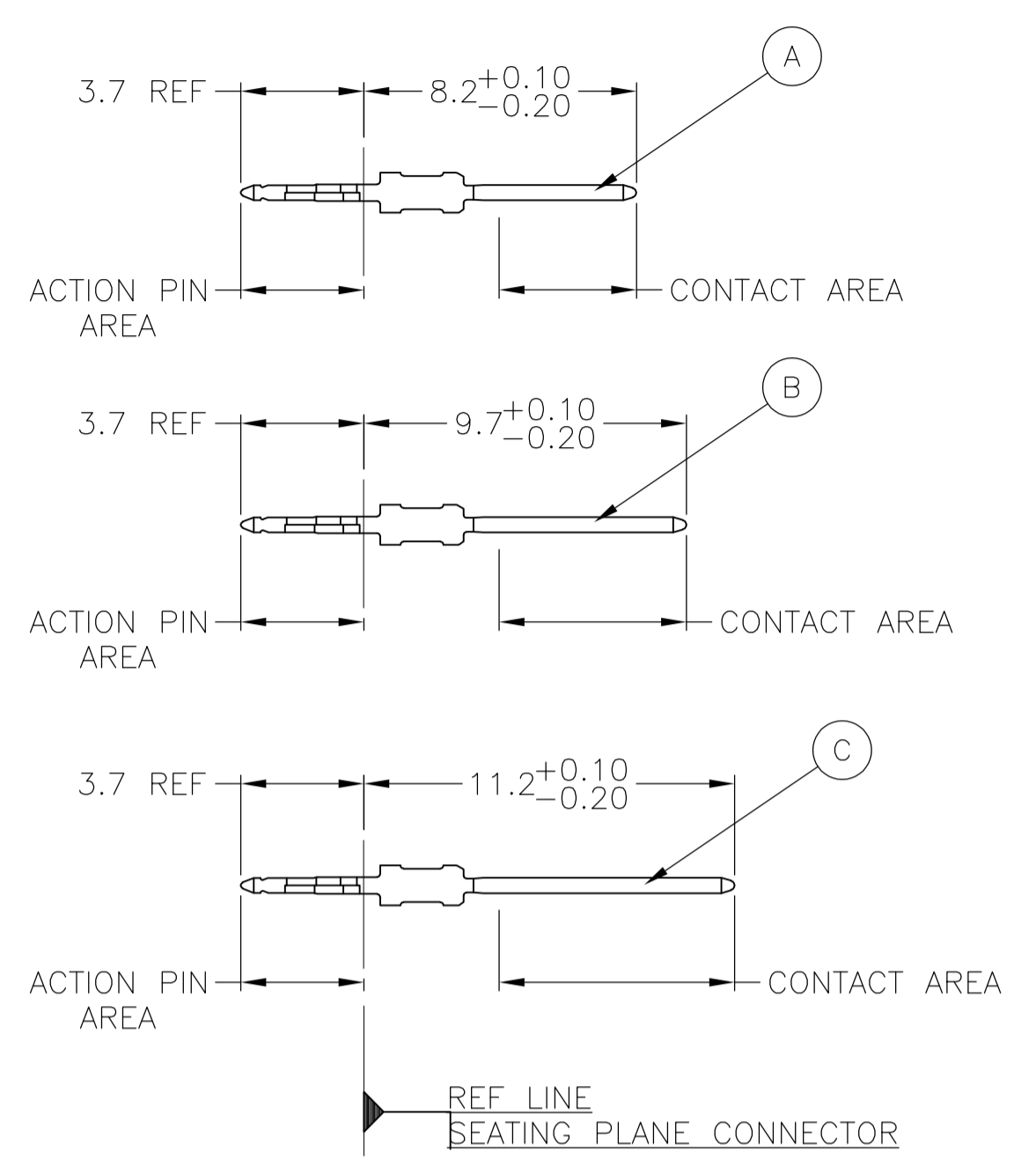

CONTACT LAYOUT

	z	a	b	c	d	e	f
1	C	B	B	A	B	B	C
2	C	B	B	A	B	B	C
3	C	B	B	A	B	B	C
4	C	B	B	A	B	B	C
5	C	B	B	A	B	B	C
6	C	B	B	A	B	B	C
7	C	B	B	A	B	B	C
8	C	B	B	A	B	B	C
9		B	B	A	B	B	
10		B	B	A	B	B	
11		B	B	A	B	B	
12	C	B	B	A	B	B	C
13	C	B	B	A	B	B	C
14	C	B	B	A	B	B	C
15	C	B	B	A	B	B	C
16	C	B	B	A	B	B	C
17	C	B	B	A	B	B	C
18	C	B	B	A	B	B	C
19	C	B	B	A	B	B	C

RECOMMENDED PCB-HOLE LAYOUT COMPONENT SIDE SHOWN

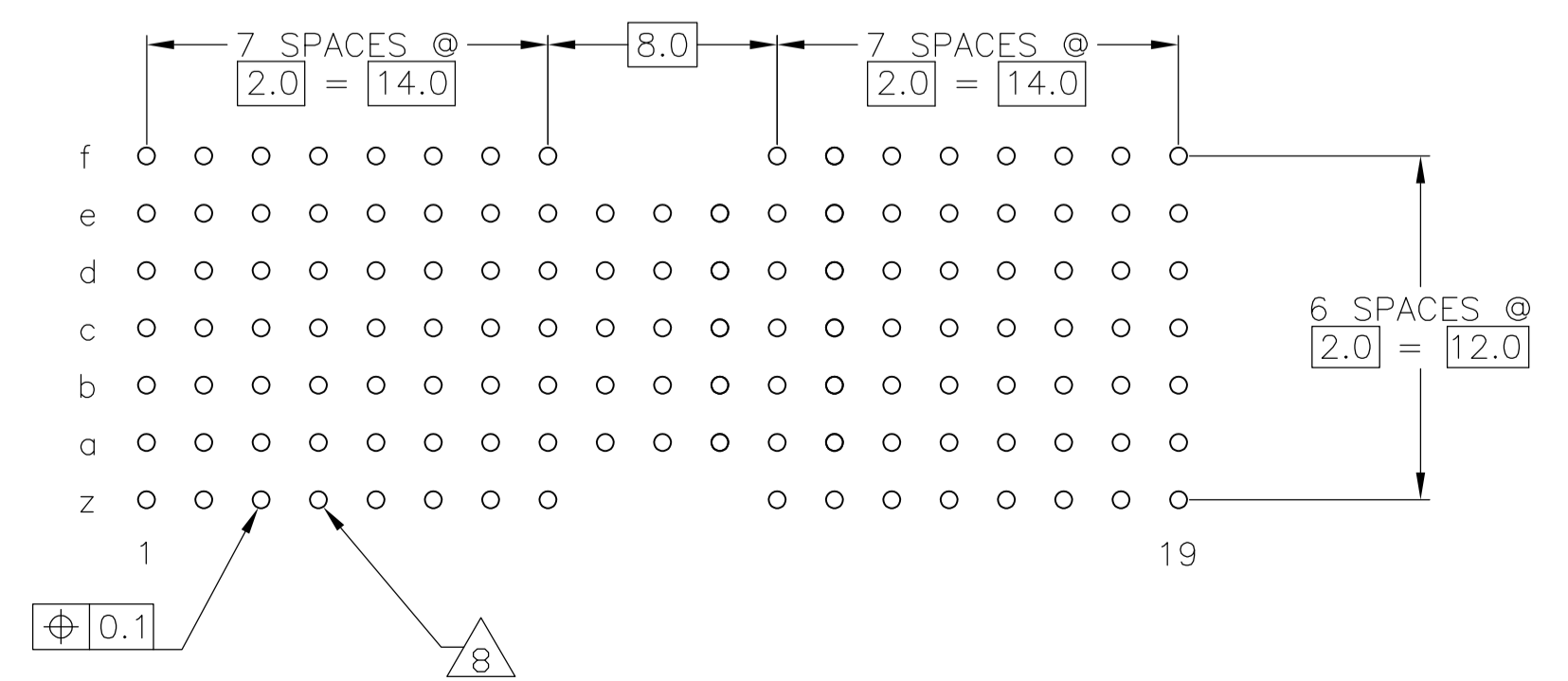

PLATED THRU HOLES PARAMETERS REFERENCE APPLICATION SPECIFICATION

2	6	12	1-6645156-9
2	5	12	6645156-9
2	4		6645156-4
2	3		6645156-1
FINISH			PART NUMBER

THIS DRAWING IS A CONTROLLED DOCUMENT.

DIMENSIONS: mm	TOLERANCES UNLESS OTHERWISE SPECIFIED:	DIN B CARBO 19MAY05	GSKIPPER 19MAY05	Tyco Electronics Corporation Harrisburg, Pa 17105-3608
0-PLC ±	1-PLC ±0.1	APVD GSKIPPER 19MAY05	NAME	MALE ASSEMBLY, Z-PACK 2mm HM, TYPE A/B
2-PLC ±	3-PLC ±	PRODUCT SPEC	108-19082	APPLICATION SPEC
4-PLC ±	ANGLES	114-19029	SIZE	CAGE CODE
1	SEE TABLE	WEIGHT	A100779	DRAWING NO
			C=6645156	RESTRICTED TO
			CUSTOMER DRAWING	SCALE 4:1 SHEET 1 OF 2 REV A

LOC		DIST		REVISIONS			
P	LTR	DESCRIPTION	DATE	DN	APVD		
AD	00	SEE SHEET 1					

- 1 MATERIAL:
CONTACT: PHOSPHOR BRONZE.
HOUSING: GLASS-FILLED POLYESTER.
- 2 GENERAL PLATING SPECIFICATION: UNDERPLATING
(ENTIRE CONTACT): 1.27µm MIN NICKEL AND ACTION
PIN: 0.5µm MIN TIN.
FOR PLATING OF MATING SURFACES SEE APPLICABLE
SPECIFICATION REFERENCE FOR EACH DASH NUMBER.
- 3 CONFORMS TO ALL TESTING ACCORDING TO IEC 61076-4-101
PERFORMANCE LEVEL 2.
- 4 CONFORMS TO ALL TESTING ACCORDING TO IEC 61076-4-101
PERFORMANCE LEVEL 1.
- 5 CONNECTOR TESTED AND QUALIFIED AGAINST TELCORDIA GR-1217-CORE QUALITY LEVEL 3,
CENTRAL OFFICE APPLICATIONS.
- 6 CONNECTOR TESTED AND QUALIFIED AGAINST TELCORDIA GR-1217-CORE QUALITY LEVEL 3,
UNCONTROLLED ENVIROMENT APPLICATIONS.
- 7 CONNECTOR MARKED WITH PART NUMBER AND DATE CODE.
ADDITIONAL CHARACTERS OR MARKINGS, AS WELL AS THE LOCATION OF THE MARKINGS,
MAY BE ADDED FOR TRACEABILITY BASED UPON MANUFACTURERS DISCRETION.
- 8 PLATED-THROUGH HOLES AT 2x2mm SQUARE GRID
PATTERN DEFINED BY CONTACT LAYOUT.
- 9 FOR ACTUAL PIN LOADING SEE "CONTACT LAYOUT".
- 10 FOR ACTUAL PIN DIMENSIONS SEE "CONTACT DIMENSIONS".
- 11 TO BE MEASURED AT BOTTOM OF SHROUD.
- 12 CONNECTOR LUBRICATED WITH BELCORE APPROVED LUBRICANT,
TECHNICAL REFERENCE: TR-NWT-001217 ISSUE 1, SEP 1992.

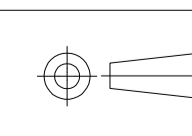
THIS DRAWING IS A CONTROLLED DOCUMENT.		DIN B CARBO 19MAY05		Tyco Electronics Corporation Harrisburg, Pa 17105-3608	
DIMENSIONS: mm		TOLERANCES UNLESS OTHERWISE SPECIFIED: ±0.2		Tyco Electronics	
		0-PLC ± 1-PLC ±0.1 2-PLC ± 3-PLC ± 4-PLC ± ANGLES ±		G.SKIPPER 19MAY05 G.SKIPPER 19MAY05 NAME: MALE ASSEMBLY, Z-PACK 2mm HM, TYPE A/B	
MATERIAL SEE SHEET 1		FINISH SEE SHEET 1		PRODUCT SPEC: 108-19082 APPLICATION SPEC: 114-19029 WEIGHT: - SIZE: A1 CAGE CODE: 00779 DRAWING NO: C=6645156 RESTRICTED TO: -	
CUSTOMER DRAWING				SCALE: 4:1 SHEET 2 OF 2 REV A	