



Chipsmall Limited consists of a professional team with an average of over 10 year of expertise in the distribution of electronic components. Based in Hongkong, we have already established firm and mutual-benefit business relationships with customers from,Europe,America and south Asia,supplying obsolete and hard-to-find components to meet their specific needs.

With the principle of "Quality Parts,Customers Priority,Honest Operation,and Considerate Service",our business mainly focus on the distribution of electronic components. Line cards we deal with include Microchip,ALPS,ROHM,Xilinx,Pulse,ON,Everlight and Freescale. Main products comprise IC,Modules,Potentiometer,IC Socket,Relay,Connector.Our parts cover such applications as commercial,industrial, and automotives areas.

We are looking forward to setting up business relationship with you and hope to provide you with the best service and solution. Let us make a better world for our industry!



## Contact us

Tel: +86-755-8981 8866 Fax: +86-755-8427 6832

Email & Skype: info@chipsmall.com Web: www.chipsmall.com

Address: A1208, Overseas Decoration Building, #122 Zhenhua RD., Futian, Shenzhen, China



### CONNECTOR ASSEMBLY EXAMPLARY LOADED 4

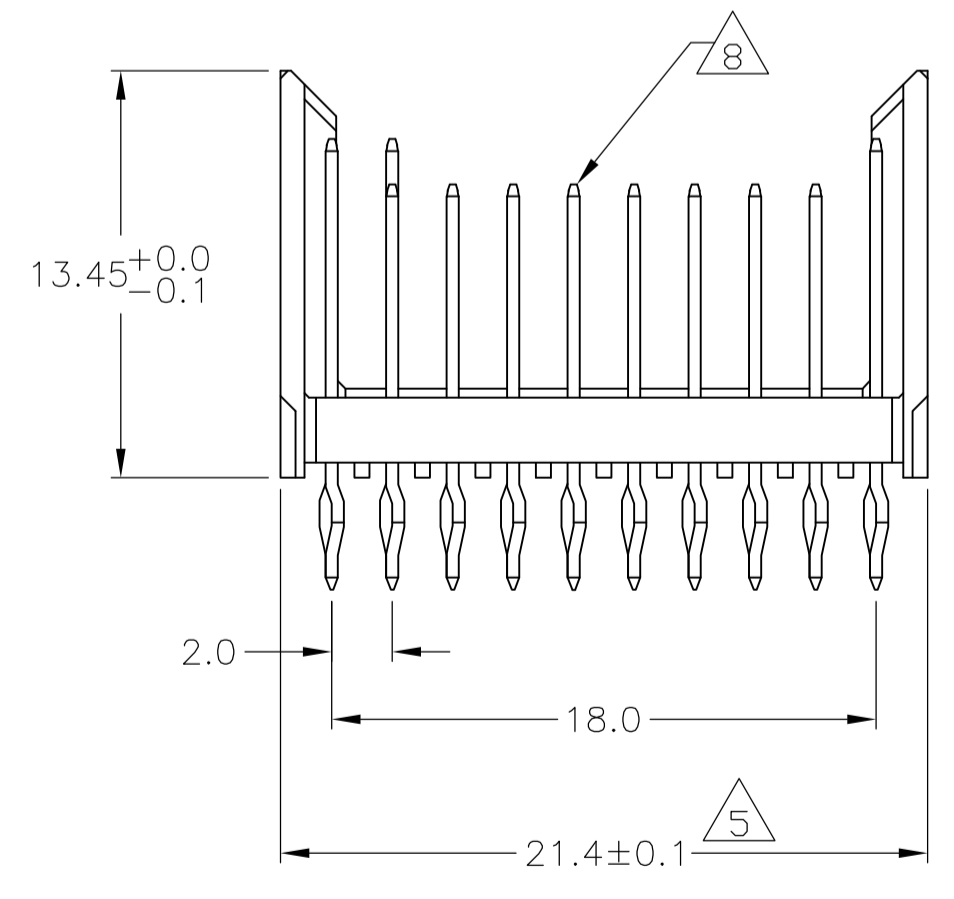
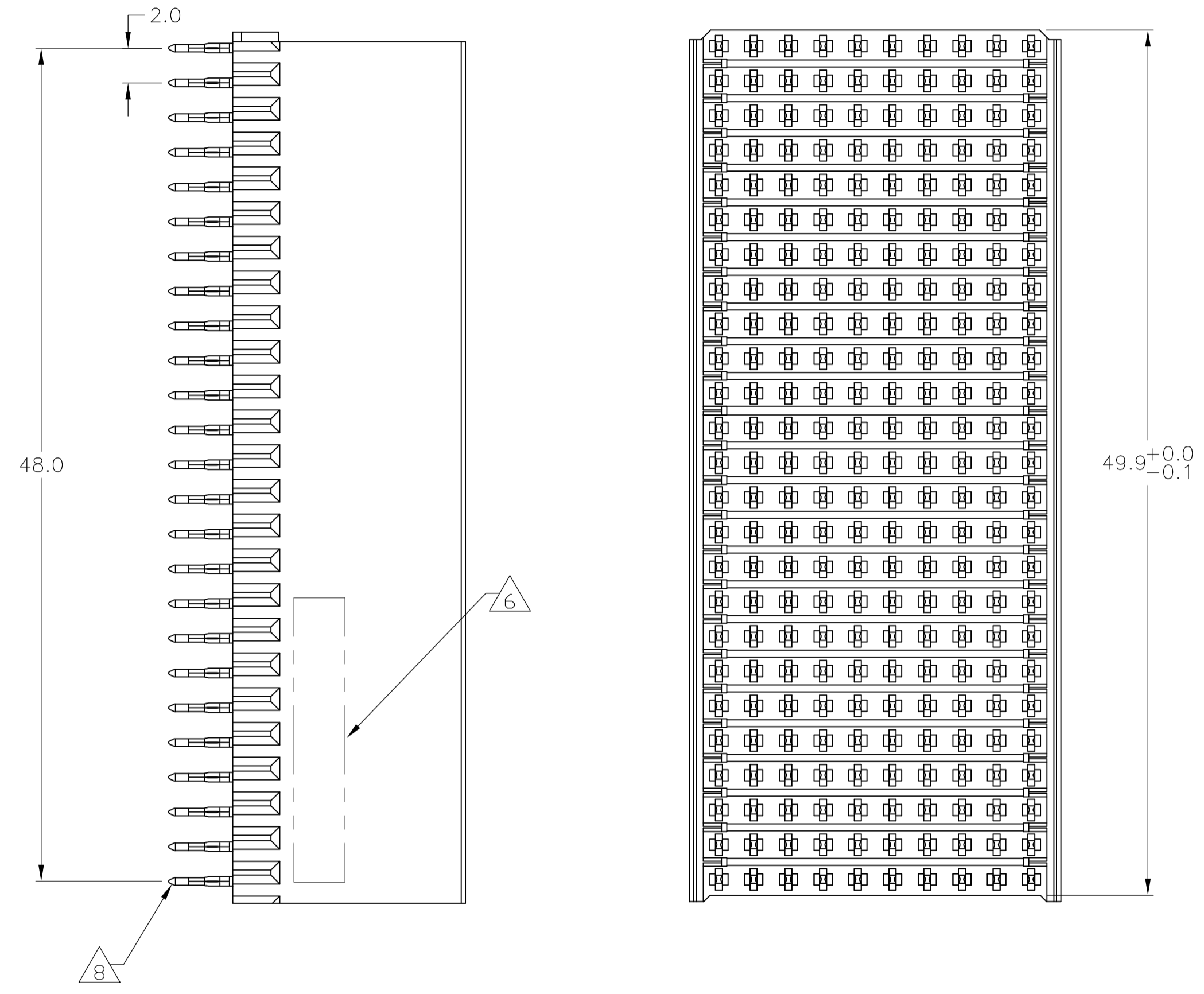

### CONTACT DIMENSIONS SCALE 5:1

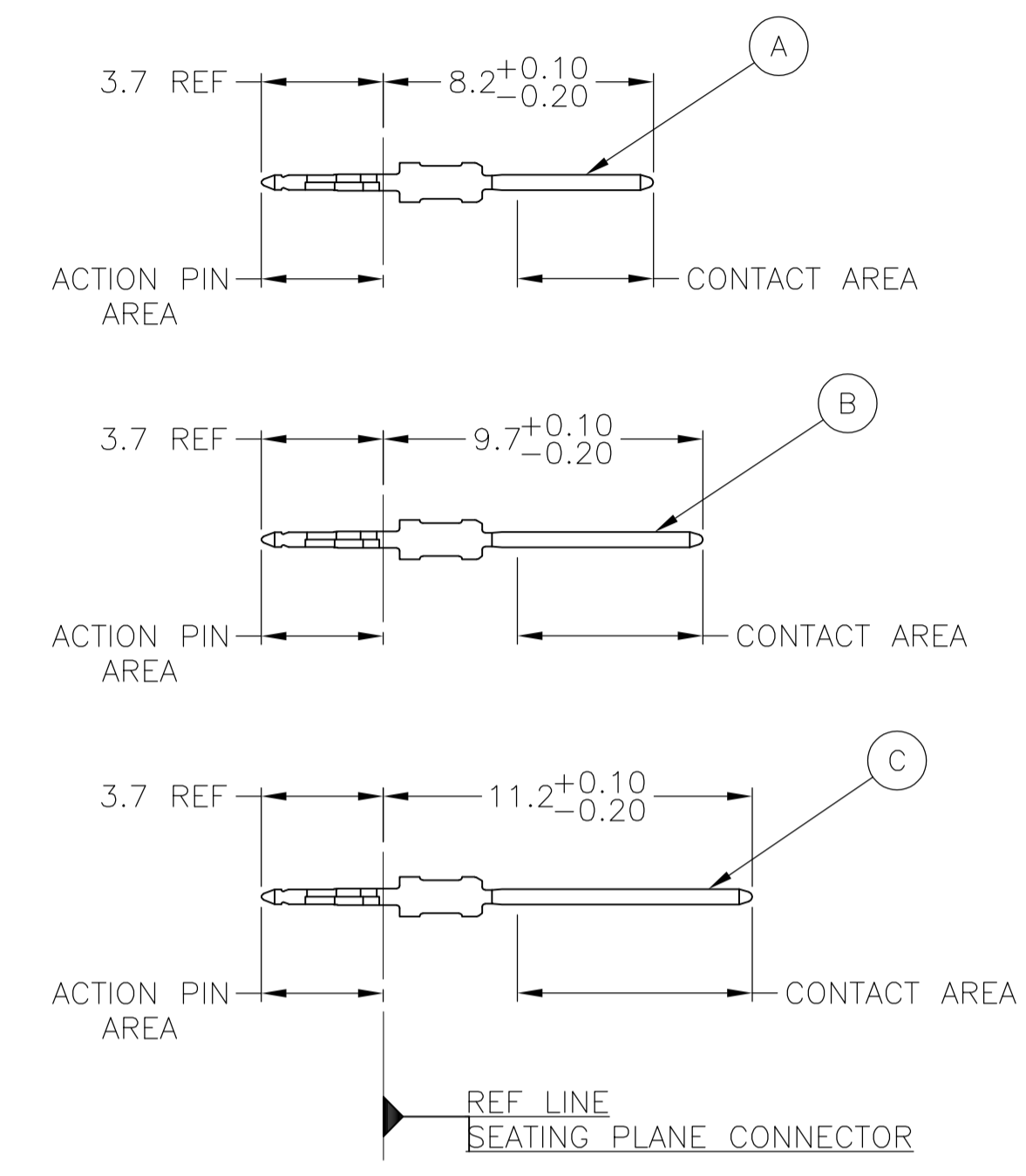

### CONTACT LAYOUT

	z	a	b	c	d	e	f	g	h	i
1	C	B	B	B	B	B	B	B	B	C
2	C	B	B	B	B	B	B	B	B	C
3	C	B	B	B	B	B	B	B	B	C
4	C	C	B	B	B	B	B	B	B	C
5	C	B	B	B	B	B	B	B	B	C
6	C	B	B	B	B	B	B	B	B	C
7	C	B	B	B	B	B	B	B	B	C
8	C	C	B	B	B	B	B	B	B	C
9	C	B	B	B	B	B	B	B	B	C
10	C	B	B	B	B	B	B	B	B	C
11	C	A	B	B	B	B	B	B	B	C
12	C	C	B	B	B	B	B	B	B	C
13	C	B	B	B	B	B	B	B	B	C
14	C	B	B	B	B	B	B	B	B	C
15	C	A	B	B	B	B	B	B	B	C
16	C	C	B	B	B	B	B	B	B	C
17	C	B	B	B	B	B	B	B	B	C
18	C	B	B	B	B	B	B	B	B	C
19	C	B	B	B	B	B	B	B	B	C
20	C	B	B	B	B	B	B	B	B	C
21	C	B	B	B	B	B	B	B	B	C
22	C	B	B	B	B	B	B	B	B	C
23	C	B	B	B	B	B	B	B	B	C
24	C	B	B	B	B	B	B	B	B	C
25	C	B	B	B	B	B	B	B	B	C

### RECOMMENDED PCB-HOLE LAYOUT COMPONENT SIDE SHOWN

### PLATED THRU HOLES PARAMETERS REFERENCE APPLICATION SPECIFICATION

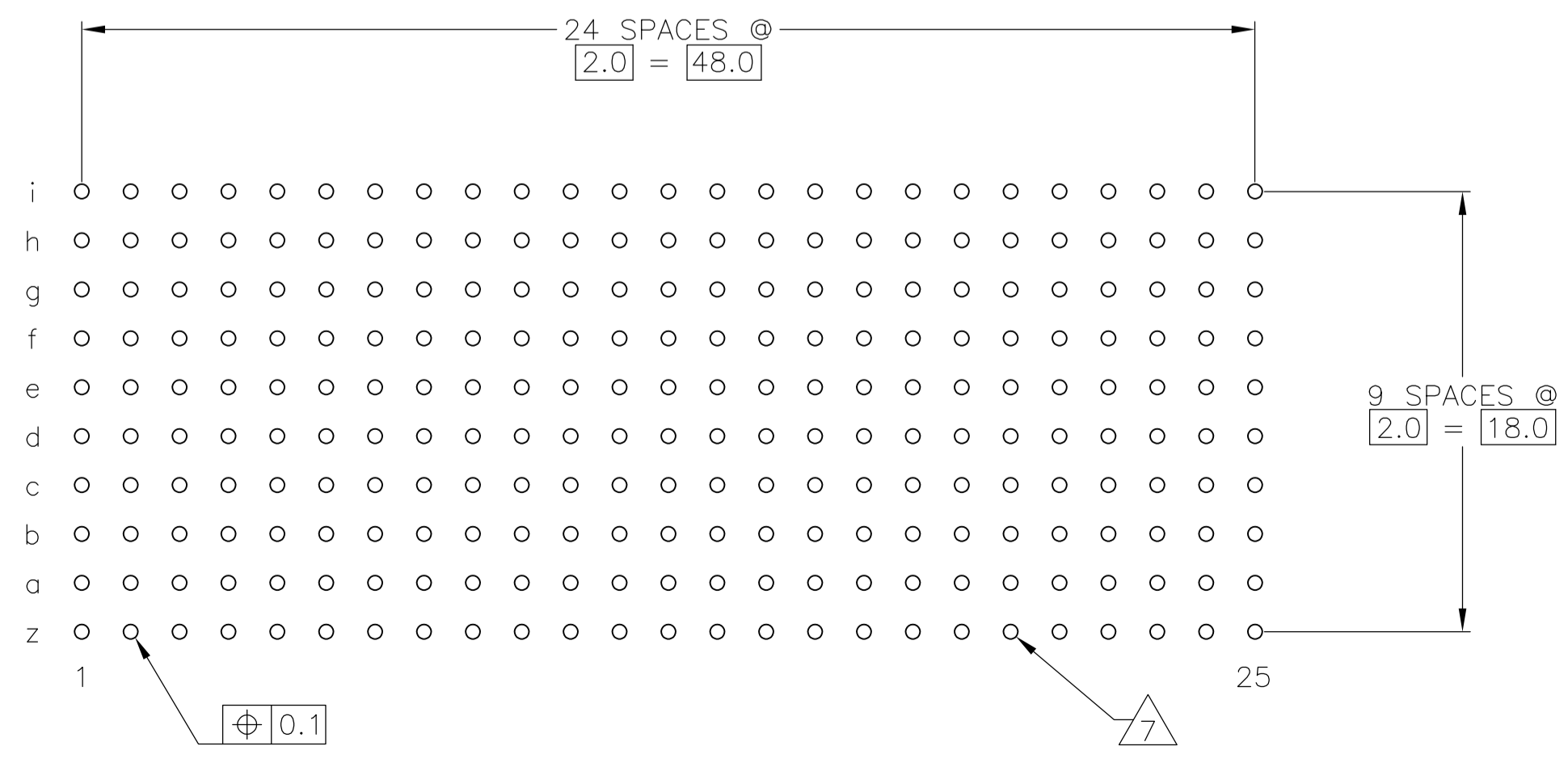

THIS DRAWING IS A CONTROLLED DOCUMENT.		DIN MAN_YI 15MAY2012		6645343-1	
TOLERANCES UNLESS OTHERWISE SPECIFIED:		CHK SANDERS_YAN 15MAY2012		FINISH PART NUMBER	
0-PLC ±		NAME ALEX_CAL 15MAY2012		STE TE Connectivity	
1-PLC ±0.1		PRODUCT SPEC 108-19082		MALE ASSEMBLY, Z-PACK 2mm HM, TYPE E, 250 POSITION	
2-PLC ±		APPLICATION SPEC 114-19029		SIZE CAGE CODE DRAWING NO. RESTRICTED TO	
3-PLC ±		WEIGHT		A1 00779 C=6645343	
4-PLC ±		MATERIAL		CUSTOMER DRAWING SCALE 4:1 SHEET 1 OF 2 REV B	
ANGLES ±		FINISH SEE TABLE			

LOC		DIST		REVISIONS				
P	LTR	DESCRIPTION	DATE	DN	APVD			
-	-	SEE SHEET 1	-	-	-			

- 1 MATERIAL:  
CONTACT: COPPER ALLOY.  
HOUSING: GLASS-FILLED POLYESTER.
- 2 GENERAL PLATING SPECIFICATION: UNDERPLATING  
(ENTIRE CONTACT): 1.27µm MIN NICKEL AND ACTION  
PIN: 0.5µm MIN TIN.  
FOR PLATING OF MATING SURFACES SEE APPLICABLE  
SPECIFICATION REFERENCE FOR EACH DASH NUMBER.
- 3 CONFORMS TO ALL TESTING ACCORDING TO IEC 61076-4-101  
PERFORMANCE LEVEL 2.
- 4 FOR ACTUAL PIN LOADING, SEE "CONTACT LAYOUT"
- 5 TO BE MEASURED AT BOTTOM OF SHROUD.
- 6 CONNECTOR MARKED WITH PART NUMBER AND DATE CODE.  
ADDITIONAL CHARACTERS OR MARKINGS, AS WELL AS THE LOCATION OF THE MARKINGS,  
MAY BE ADDED FOR TRACEABILITY BASED UPON MANUFACTURERS DISCRETION.
- 7 PLATED-THROUGH HOLES AT 2x2mm SQUARE GRID  
PATTERN DEFINED BY CONTACT LAYOUT.
- 8 FOR ACTUAL PIN DIMENSIONS SEE "CONTACT DIMENSIONS".

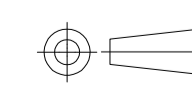
THIS DRAWING IS A CONTROLLED DOCUMENT.		DIN MAN. YI 15MAY2012		 TE Connectivity	
		CHK SANDERS, YAN 15MAY2012			
DIMENSIONS: mm		TOLERANCES UNLESS OTHERWISE SPECIFIED: ±0.2		NAME ALEX, CAL 15MAY2012	
		0-PLC ±		PRODUCT SPEC 108-19082	
		1-PLC ±0.1		APPLICATION SPEC 114-19029	
MATERIAL SEE SHEET 1		FINISH SEE SHEET 1		RESTRICTED TO —	
		WEIGHT —		SIZE A1	
		CUSTOMER DRAWING		SCALE 4:1 SHEET 2 OF 2 REV B	