



Chipsmall Limited consists of a professional team with an average of over 10 year of expertise in the distribution of electronic components. Based in Hongkong, we have already established firm and mutual-benefit business relationships with customers from,Europe,America and south Asia,supplying obsolete and hard-to-find components to meet their specific needs.

With the principle of “Quality Parts,Customers Priority,Honest Operation,and Considerate Service”,our business mainly focus on the distribution of electronic components. Line cards we deal with include Microchip,ALPS,ROHM,Xilinx,Pulse,ON,Everlight and Freescale. Main products comprise IC,Modules,Potentiometer,IC Socket,Relay,Connector.Our parts cover such applications as commercial,industrial, and automotives areas.

We are looking forward to setting up business relationship with you and hope to provide you with the best service and solution. Let us make a better world for our industry!



## Contact us

Tel: +86-755-8981 8866 Fax: +86-755-8427 6832

Email & Skype: info@chipsmall.com Web: www.chipsmall.com

Address: A1208, Overseas Decoration Building, #122 Zhenhua RD., Futian, Shenzhen, China



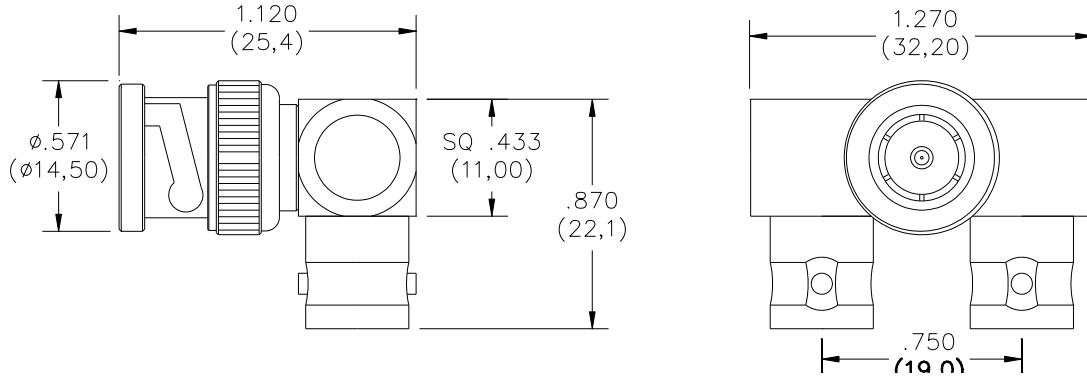

### Features:

- ✓ The modified “ T ” adapter maximizes space by allowing a right-angle connection of BNC cables into the body instead of the side as with conventional “ T “ adapters.
- ✓ Ideal for cross-connect panels requiring multiple BNC connections.
- ✓ Adapter is precision machined (not die-cast) from brass.

### Materials:

Connector Body	Nickel plated brass
Center Contact Pin	Gold plated brass
Center Contact Socket	Gold plated phosphor bronze
Insulator	Polybutylene Terephthalate
Rubber Gasket	Silicone rubber

### Ratings:

Impedance:	50 Ohms
Frequency:	0 to 4 GHz
VSWR:	1.30 max
Contact Resistance:	3 Milliohms max.
Voltage	* 500 V
Insulation Resistance:	5,000 Megohms min.
Insertions:	500
Temperature:	-40 to +85 C

\* *Hands free testing* in controlled voltage environment: *For CE compliance:* not intended for hand held use at voltages above 33 Vrms / 70 Vdc.

All dimensions are in inches. Tolerances (except noted): .xx = ±.02" (.51 mm), .xxx = ±.005" (.127 mm).

All specifications are to the latest revisions. Specifications are subject to change without notice.

Registered trademarks are the property of their respective companies. Made in USA

Sales: 800-490-2361 Fax: 888-403-3360 Technical Assistance: 800-241-2060  
For “Where to Buy” information, visit the Pomona web site at [www.pomonaelectronics.com](http://www.pomonaelectronics.com)