



Chipsmall Limited consists of a professional team with an average of over 10 year of expertise in the distribution of electronic components. Based in Hongkong, we have already established firm and mutual-benefit business relationships with customers from,Europe,America and south Asia,supplying obsolete and hard-to-find components to meet their specific needs.

With the principle of “Quality Parts,Customers Priority,Honest Operation,and Considerate Service”,our business mainly focus on the distribution of electronic components. Line cards we deal with include Microchip,ALPS,ROHM,Xilinx,Pulse,ON,Everlight and Freescale. Main products comprise IC,Modules,Potentiometer,IC Socket,Relay,Connector.Our parts cover such applications as commercial,industrial, and automotives areas.

We are looking forward to setting up business relationship with you and hope to provide you with the best service and solution. Let us make a better world for our industry!



## Contact us

Tel: +86-755-8981 8866 Fax: +86-755-8427 6832

Email & Skype: info@chipsmall.com Web: www.chipsmall.com

Address: A1208, Overseas Decoration Building, #122 Zhenhua RD., Futian, Shenzhen, China



**Model 6713**  
**Adapter Push-on Plug Jack (F/M)**

**Features:**

- The adapter attaches to cables with male F style connector, which then allows the cable to simply slip on and off, quickly and reliably to female F connectors.
- The “push-on” adapter is ideal for testing and manufacturing environments.
- Adapter is precision machined (not die-cast) from brass.

**Materials:**

Connector Body: Nickel plated brass  
Center Contact: Nickel plated brass  
Insulator (F): Polystyrene  
Insulator (M): Polybutylene Terephthalate

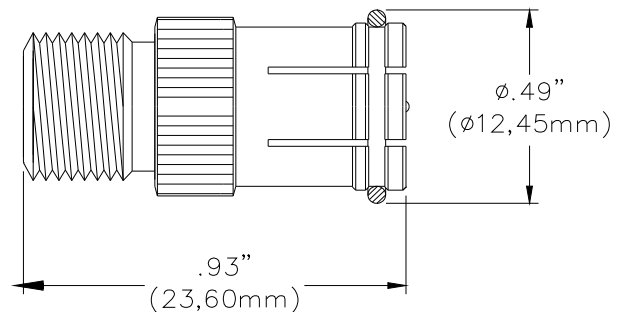

**Ratings:**

Impedance:	75 Ohms	
Frequency:	0 to 500 MHz	
VSWR:	1.5 max	
Contact Resistance:	3 Milliohms max.	
Max Voltage	* 500 V	
Insulation Resistance:	5,000 Megohms min.	
Insertions:	500	
Temperature:	-40 to +65 C	
* Hands free testing in controlled voltage environment: For CE compliance: not intended for hand held use at voltages above 33 Vrms / 70 Vdc.		

USA: Sales: 800-490-2361 Technical Support: 800-241-2060 Fax: 888-403-3360

Europe: 31-(0) 40 2675 150 International: 425-446-5500  
e-mail: [technicalsupport@pomonatest.com](mailto:technicalsupport@pomonatest.com)

Where to Buy: [www.pomonaelectronics.com](http://www.pomonaelectronics.com)

All dimensions are in inches. Tolerances (except noted): .xx = ±.02" (.51 mm), .xxx = ±.005" (.127 mm). All specifications are to the latest revisions. Specifications are subject to change without notice. Registered trademarks are the property of their respective companies.