



Chipsmall Limited consists of a professional team with an average of over 10 year of expertise in the distribution of electronic components. Based in Hongkong, we have already established firm and mutual-benefit business relationships with customers from,Europe,America and south Asia,supplying obsolete and hard-to-find components to meet their specific needs.

With the principle of “Quality Parts,Customers Priority,Honest Operation,and Considerate Service”,our business mainly focus on the distribution of electronic components. Line cards we deal with include Microchip,ALPS,ROHM,Xilinx,Pulse,ON,Everlight and Freescale. Main products comprise IC,Modules,Potentiometer,IC Socket,Relay,Connector.Our parts cover such applications as commercial,industrial, and automotives areas.

We are looking forward to setting up business relationship with you and hope to provide you with the best service and solution. Let us make a better world for our industry!



Contact us

Tel: +86-755-8981 8866 Fax: +86-755-8427 6832

Email & Skype: info@chipsmall.com Web: www.chipsmall.com

Address: A1208, Overseas Decoration Building, #122 Zhenhua RD., Futian, Shenzhen, China



PRODUCT NUMBER

SEE TABLE

68046 - XXX - LF

- LEAD FREE OPTION
- PACKAGING OPTION NOTE 6. OMIT IF NOT REQUIRED
- NO OF POSITIONS PER ROW
- PLATING CODE
- BASE PART NUMBER

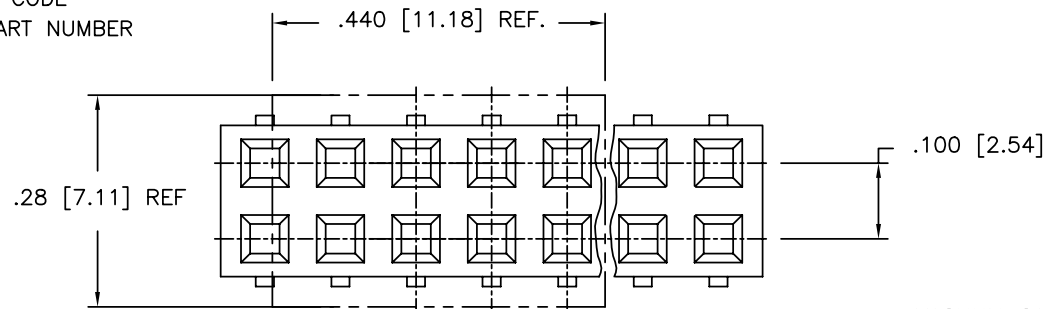

VACUUM CAP FOR TAPE & REEL PACKAGING OPTION. NOTE 8

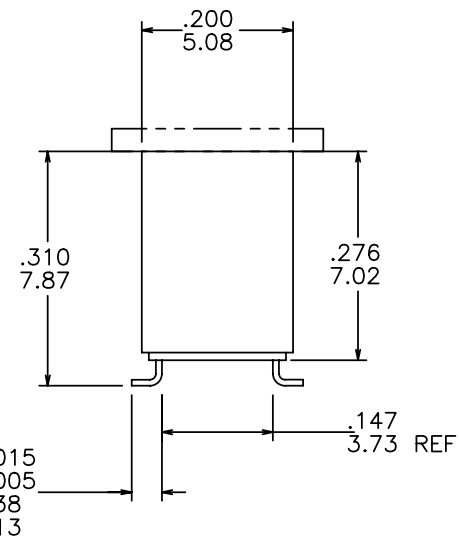
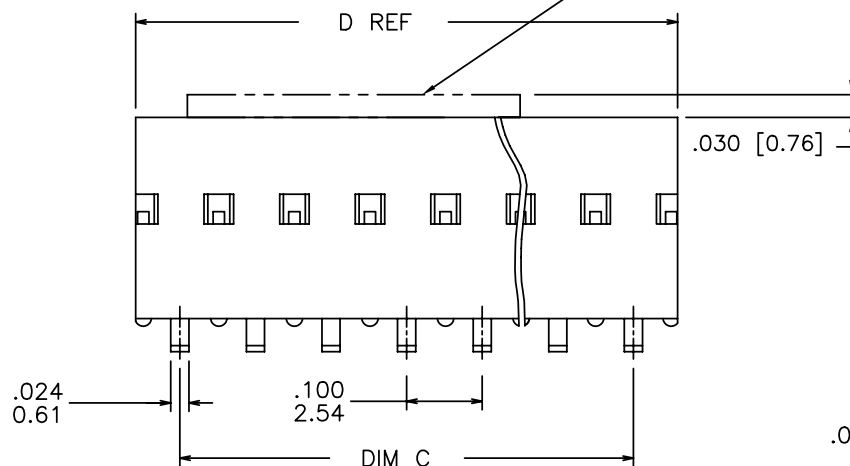

mat'l. code		surface ISO 1302 ✓		tolerance ISO 406 ISO 1101		projection INCH/MM		product family DUBOX	
ltr ecn no dr date		tolerances unless otherwise specified		title		scale 1:1		SMT DOUBLE ROW VCC ASSEMBLY	
AV	N-005264	SH	2011-8-25	angles	XXX±.01/XX±.3			dwg no	
AN	V04-0986	DAI	10/13/04	linea	XXX±.005/XX±.13			sheet # of 5	
AP	V04-1003	DAI	10/25/04	0°±2'	XXX±.0020/XXX±.05			size	
AR	V05-0463	DPU	06/28/05	chr	J. SHREINER	11/07/90		68046	
AS	M07-0143	ERE	03/03/07	engr	M. HAHN	11/07/90		A3	
AT	M07-0203	AGS	5/02/07	chr	M. HAHN	11/07/90		type	
AU	M08-0065	MHT	3/04/05	appd	M. HAHN	11/07/90		Product Customer Drawing	
sheet	revisio	AV	AV	AV	AV	AV			
index	sheet	1	2	3	4	5			



Copyright FCI

PRODUCT NUMBER NOTE 15	PLATING CONTACT AREA	PLATING SOLDER TAIL	MATERIAL REF
68046-2XX	15μ"/.38μ Au OR GXT MIN OVER 50μ"/1.27μ Ni MIN	100μ"/160μ" 2.54μ"/4.06μ" SN	NOTE 3&4
68046-3XX	30μ"/.76μ Au OR GXT MIN OVER 50μ"/1.27μ Ni MIN	100μ"/160μ" 2.54μ"/4.06μ" SN	NOTE 3&4
68046-4XX	100μ"/2.54 SN MIN OVER 50μ"/1.27μ Ni MIN	100μ"/160μ" 2.54μ"/4.06μ" SN	NOTE 3,4&17
68046-6XX	30μ"/.76μ Au OR GXT MIN OVER 50μ"/1.27μ Ni MIN	100μ"/160μ" 2.54μ"/4.06μ" SN	NOTE 3&4
68046-8XX	30μ"/.76μ Au MIN OVER 50μ"/1.27μ Ni MIN	200μ"/5.08μ SL MIN	NOTE 3&4

OBSOLETE

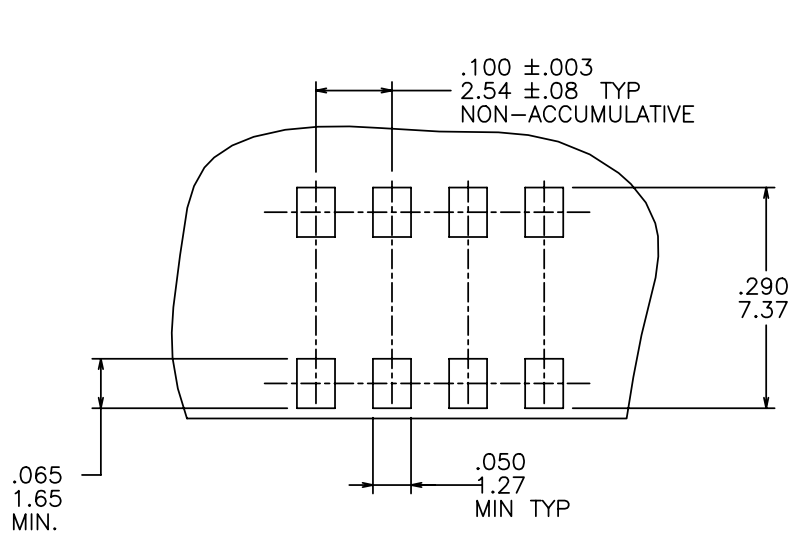

FIGURE A
TOP ENTRY
.025/.64 SQ PIN

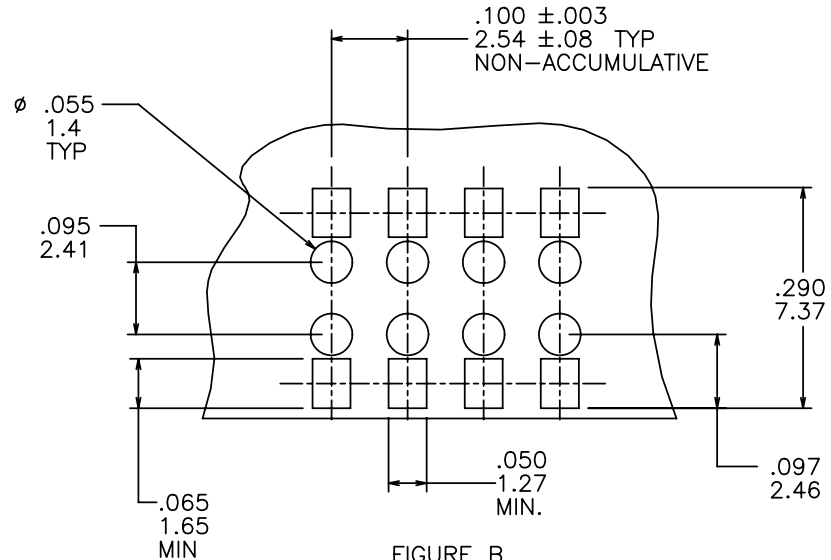
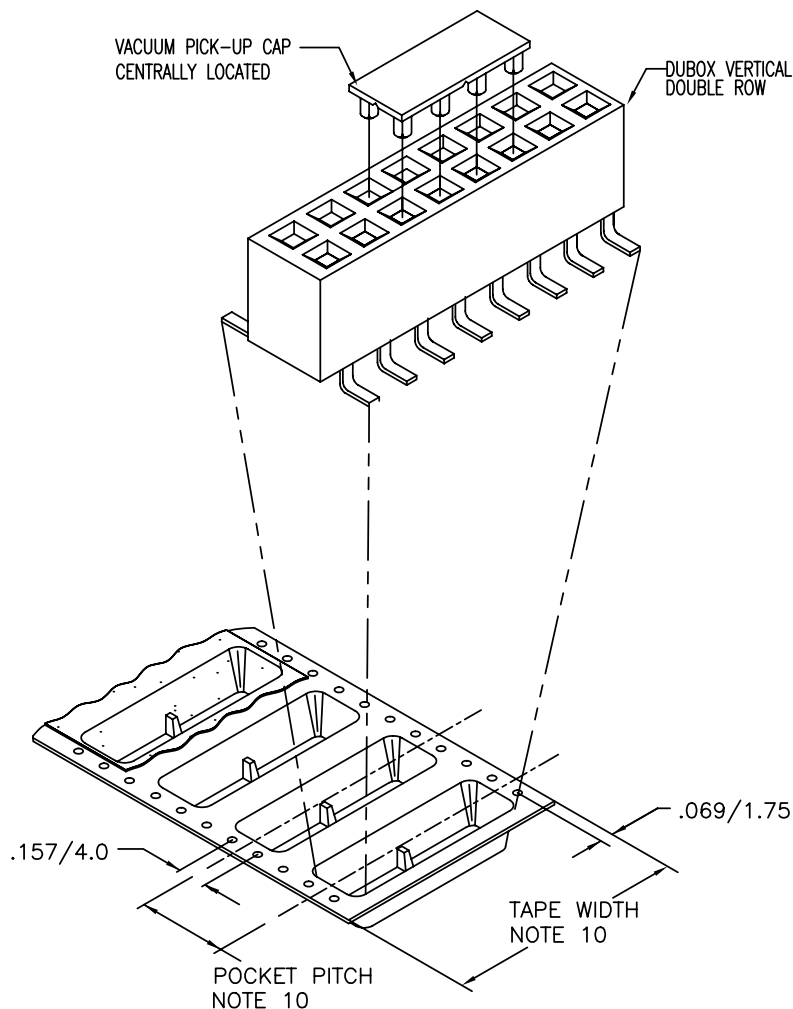

FIGURE B
BOTTOM ENTRY (THROUGH PWB)
.025/.64 SQ PIN

mat'l. code	surface ISO 1302 ✓	tolerance ISO 406 ISO 1101	projection INCH/MM	product family DUBOX
tr.ecn nodr date	tolerances unless otherwise specified		title SMT DOUBLE ROW VCC ASSEMBLY	dwg no 68046
AV	angles 0°±2'	line XXX±.01/XX±.3 XXX±.005/XX±.13 XXX±.0020/XXX±.05	scale 1:1	sheet 2 of 5 size A3
	dr J. SHREINER	11/07/90	FCI	type Product Customer Drawing
	enr M. HAHN	11/07/90		
	chr M. HAHN	11/07/90		
	app M. HAHN	11/07/90		
sheet index	revision sheet			

VACUUM PICK-UP CAP
CENTRALLY LOCATED

DUBOX VERTICAL RECEPTACLE
DOUBLE ROW



TAPE AND REEL PACKAGING

SEE NOTE 7

NOTES:

- ①. TERMINAL MATERIAL: PHOSPHOR BRONZE.
EXTRA HARD
2. RECOMMENDED APPLICATION SOLDER DATA:
A. RECOMMENDED SOLDER PAD PATTERN IS SHOWN IN FIGURE A & B.
B. ALL MATING PINS TO BE .025/.64 SQUARE ON TRUE CENTER OF
ON GIVEN TERMINAL SPACING WITHIN .015/.38 DIA.
C. SUGGESTED MATING PIN LENGTH .210±.010 [5.33±.51]
- ③. HOUSING MATERIAL: P.P.S. FILLED.
FLAME RETARDANT PER UL-94-V0.
COMPATIBLE WITH INFRA-RED SOLDERING.
COLOR: BLACK
PART WILL WITHSTAND EXPOSURE TO 260° C PEAK TEMPERATURE
FOR 20 SEONDS IN WAVE SOLDER,INFRA-RED OR
VAPOR PHASE SOLDER PROCESS.
- ④. PRESTAMPED POST PLATED TERMINAL.
5. FCI, FCI FINAL PART NUMBER AND DATE CODE
TO BE MARKED ON TUBE LABEL.
6. ADD SUFFIX 'P' TO DASH NUMBER AS FOURTH DIGIT FOR TAPE & REEL
PACKAGING.
- ⑦. TAPE AND REEL PACKAGING PER GES-14-334.
- ⑧. VACUUM CAP MATERIAL: L.C.P., FLAME RETARDANT UL 94 V-0.
COLOR : BLACK
CAP IS USED WITH TAPE AND REEL PACKAGING.
CAP IS TO BE CENTRALLY LOCATED ON PART.
9. TAPE AND REEL PACKAGING FOR 24mm WIDE AND BELOW HAVE PILOT HOLES ON
ONE SIDE OF TAPE ONLY. SIZES ABOVE 24mm HAVE PILOT HOLES ON BOTH
OF TAPE.
- ⑩. TAPE & REEL PACKAGING 24mm AND 32mm TAPE WIDTH, WITH 112mm POCKET
PITCH.
11. MAXIMUM LENGTH OF CONNECTOR FOR TAPE AND REEL PACKAGING IS 2.50
LONG /63.5mm
- ⑫. PART NUMBER WITH SUFFIX "U" IS FOR SAWING PURPOSES ONLY.
13. STANDARD TUBE PACKAGE PER BUS-14-097/3.
- ⑭. TAPE & REEL PACKAGING 72mm TAPE WIDTH WITH 16mm POCKET PITCH.
- ⑮. ADD LF SUFFIX AT THE END OF PART NUMBER FOR LEAD FREE OPTION
16. THESE PRODUCTS MEETS EUROPEAN UNION DIRECTIVES AND OTHER
COUNTRY REGULATION AS DESCRIBED IN GS-22-008.
- ⑰. "THIS PRODUCT HAS 100% TIN PLATING IN THE INTERFACE AND
HAS NOT BEEN TESTED FOR WHISKER GROWTH IN ALL INTERCONNECT
ENVIRONMENTS".

mat'l. code		surface ISO 1302 ✓		tolerance ISO 406 ISO 1101		projection ⊕		product family DUBOX	
ltr ecn nodr		date		tolerances unless otherwise specified		title		SMT DOUBLE ROW VCC ASSEMBLY	
AV				angles 0°±2'		linea XXX±.01/XX±.3 XXX±.0005/XX±.13 XXX±.0020/XXX±.05		INCH/MM scale 1:1	
dr		J. SHREINER		11/07/90		FCI		dwg no 68046	
engr		M. HAHN		11/07/90				sheet of 5 3	
chr		M. HAHN		11/07/90				size A3	
appd		M. HAHN		11/07/90				type Product Customer Drawing	
sheet		revision							
index		sheet							



FCIconnect.com

Copyright FCI

PRODUCT NUMBER	NO. OF POS.	C DIM	D DIM	TAPE & REEL PACKAGING	LF OPTION
68046-Y02	2 X 2	.100/2.540	.217/5.511	NO	NOTE 15
-Y03	2 X 3	.200/5.080	.317/8.051	NO	
-Y04	2 X 4	.300/7.620	.417/10.591	NO	
-Y05	2 X 5	.400/10.160	.517/13.131	NO	
-Y06	2 X 6	.500/12.700	.617/15.671	NO	
-Y07	2 X 7	.600/15.240	.717/18.211	NO	
-Y08	2 X 8	.700/17.780	.817/20.751	NO	
-Y09	2 X 9	.800/20.320	.917/23.291	NO	
-Y10	2 X 10	.900/22.860	1.017/25.831	NO	
-Y11	2 X 11	1.000/25.400	1.117/28.371	NO	
-Y12	2 X 12	1.100/27.940	1.217/30.911	NO	
-Y13	2 X 13	1.200/30.480	1.317/33.451	NO	
-Y14	2 X 14	1.300/33.020	1.417/35.991	NO	
-Y15	2 X 15	1.400/35.560	1.517/38.531	NO	
-Y16	2 X 16	1.500/38.100	1.617/41.071	NO	
-Y17	2 X 17	1.600/40.640	1.717/43.611	NO	
-Y18	2 X 18	1.700/43.180	1.817/46.151	NO	
-Y19	2 X 19	1.800/45.720	1.917/48.691	NO	
-Y20	2 X 20	1.900/48.260	2.017/51.231	NO	
-Y21	2 X 21	2.000/50.800	2.117/53.771	NO	
-Y22	2 X 22	2.100/53.340	2.217/56.311	NO	
-Y23	2 X 23	2.200/55.880	2.317/58.851	NO	
-Y24	2 X 24	2.300/58.420	2.417/61.391	NO	
68046-Y25	2 X 25	2.400/60.960	2.517/63.931	NO	

NOTE 15

mat'l. code	surface ISO 1302 ✓	tolerance ISO 406 ISO 1101	projection 	product family DUBOX
tr	ecn	nodr	date	title
AV				SMT DOUBLE ROW VCC ASSEMBLY
	angles	linea	tolerances unless otherwise specified	INCH/MM
	0°±2'	XXXX±.005/XXX±.13	XXXX±.0020/XXX±.05	scale 1:1
	dr	J. SHREINER	11/07/90	dwg no
	engr	M. HAHN	11/07/90	68046
	chr	M. HAHN	11/07/90	sheet # of 5
	appd	M. HAHN	11/07/90	A3
				type Product Customer Drawing
sheet index	revision sheet			





Copyright FCI

D

PROD. NUMBER	NO. POSI.	C DIM	D DIM	TAPE & REEL PACKAGING	LF OPTION
68046-Y26	2 X 26	2.500/63.500	2.617/66.471		NO
↑ -Y27	2 X 27	2.600/66.040	2.717/69.011		NO
-Y28	2 X 28	2.700/68.580	2.817/71.551		NO
-Y29	2 X 29	2.800/71.120	2.917/74.091		NO
-Y30	2 X 30	2.900/73.660	3.017/76.631		NO
-Y31	2 X 31	3.000/76.200	3.117/79.171		NO
-Y32	2 X 32	3.100/78.740	3.217/81.711		NO
-Y33	2 X 33	3.200/81.280	3.317/84.251		NO
-Y34	2 X 34	3.300/83.820	3.417/86.791		NO
-Y35	2 X 35	3.400/86.360	3.517/89.331		NO
-Y36	2 X 36	3.500/88.900	3.617/91.871		NO
-Y37	2 X 37	3.600/91.440	3.717/94.411		NO
-Y38	2 X 38	3.700/93.980	3.817/96.951		NO
-Y39	2 X 39	3.800/96.520	3.917/99.491		NO
-Y40	2 X 40	3.900/99.060	4.017/102.031		NO
-Y41	2 X 41	4.000/101.600	4.117/104.571		NO
-Y42	2 X 42	4.100/104.140	4.217/107.111		NO
-Y43	2 X 43	4.200/106.680	4.317/109.651		NO
-Y44	2 X 44	4.300/109.220	4.417/112.191		NO
-Y45	2 X 45	4.400/111.760	4.517/114.731		NO
-Y46	2 X 46	4.500/114.300	4.617/117.271		NO
-Y47	2 X 47	4.600/116.840	4.717/119.811		NO
-Y48	2 X 48	4.700/119.380	4.817/122.351		NO
-Y49	2 X 49	4.800/121.920	4.917/124.891		NO
-Y50	2 X 50	4.900/124.460	5.017/127.431		NO
-Y50U	2 X 50	4.900/124.460	5.017/127.431		NO
-Y03P	2 X 3	0.200/5.080	0.317/8.051	YES	
-Y04P	2 X 4	0.300/7.620	0.417/10.592	YES	
↓ -Y05P	2 X 5	0.400/10.160	0.517/13.131	YES	
68046-Y06P	2 X 6	0.500/12.700	0.617/15.671	YES	
68046-Y07P	2 X 7	0.600/15.240	0.717/18.211	YES	
-68046-Y12P	2 X 12	1.100/27.94	1.217/30.91	YES	
68046-Y13P	2 X 13	1.200/30.48	1.317/33.45	YES	
68046-Y20P	2 X 20	1.900/48.260	2.017/51.231	YES	

NOTE 15

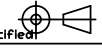
NOTE 12
 NOTE 6 & 9
 NOTE 6 & 10
 NOTE 6 & 10
 NOTE 6 & 10
 NOTE 6 & 10
 NOTE 6 & 9 — OBSOLETE
 NOTE 6 & 14
 NOTE 6 & 14

mat'l. code		surface ISO 1302 ✓	tolerance ISO 406 ISO 1101	projection 	product family DUBOX
ltr	ecn	no	date	tolerances unless otherwise specified	
AV				angles 0°±2'	line $XXX \pm 0.01 / XX \pm 3$ $XXXX \pm 0.005 / XXX \pm 13$ $XXXXX \pm 0.020 / XXX \pm 05$
				INCH/MM	title SMT DOUBLE ROW VCC ASSEMBLY
				scale 1:1	dwg no 68046
					shee 5 of 5 size A3
				dr J. SHREINER 11/07/90 engr M. HAHN 11/07/90 chr M. HAHN 11/07/90 appd M. HAHN 11/07/90	type Product Customer Drawing
sheet index	revision sheet				



Copyright FCI