



Chipsmall Limited consists of a professional team with an average of over 10 year of expertise in the distribution of electronic components. Based in Hongkong, we have already established firm and mutual-benefit business relationships with customers from,Europe,America and south Asia,supplying obsolete and hard-to-find components to meet their specific needs.

With the principle of “Quality Parts,Customers Priority,Honest Operation,and Considerate Service”,our business mainly focus on the distribution of electronic components. Line cards we deal with include Microchip,ALPS,ROHM,Xilinx,Pulse,ON,Everlight and Freescale. Main products comprise IC,Modules,Potentiometer,IC Socket,Relay,Connector.Our parts cover such applications as commercial,industrial, and automotives areas.

We are looking forward to setting up business relationship with you and hope to provide you with the best service and solution. Let us make a better world for our industry!



Contact us

Tel: +86-755-8981 8866 Fax: +86-755-8427 6832

Email & Skype: info@chipsmall.com Web: www.chipsmall.com

Address: A1208, Overseas Decoration Building, #122 Zhenhua RD., Futian, Shenzhen, China



PART NUMBER	REV	FIRST USED
680771-1	A	122500-1
680771-2	A	565435-5
680771-3	A	354500-1

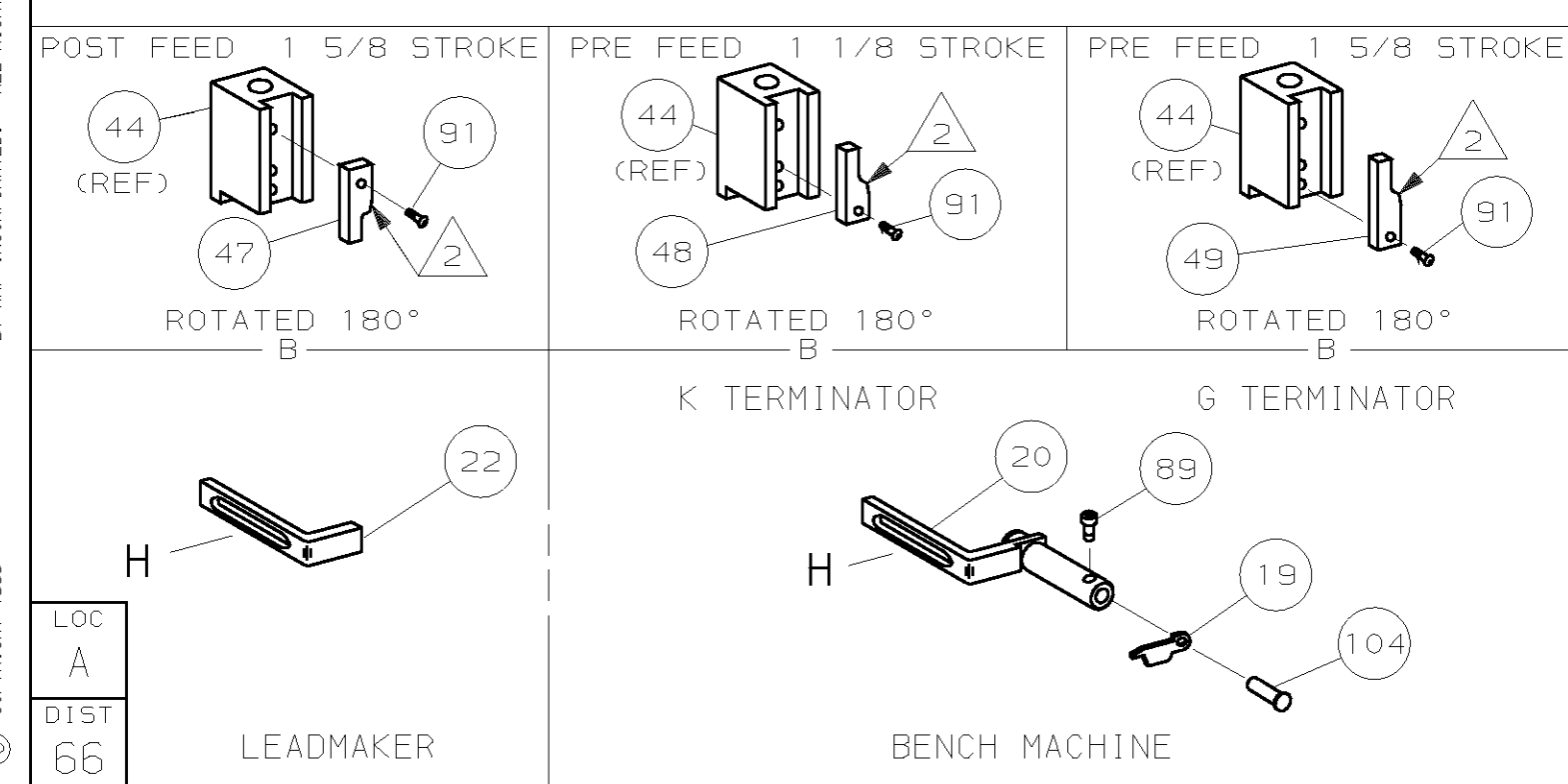
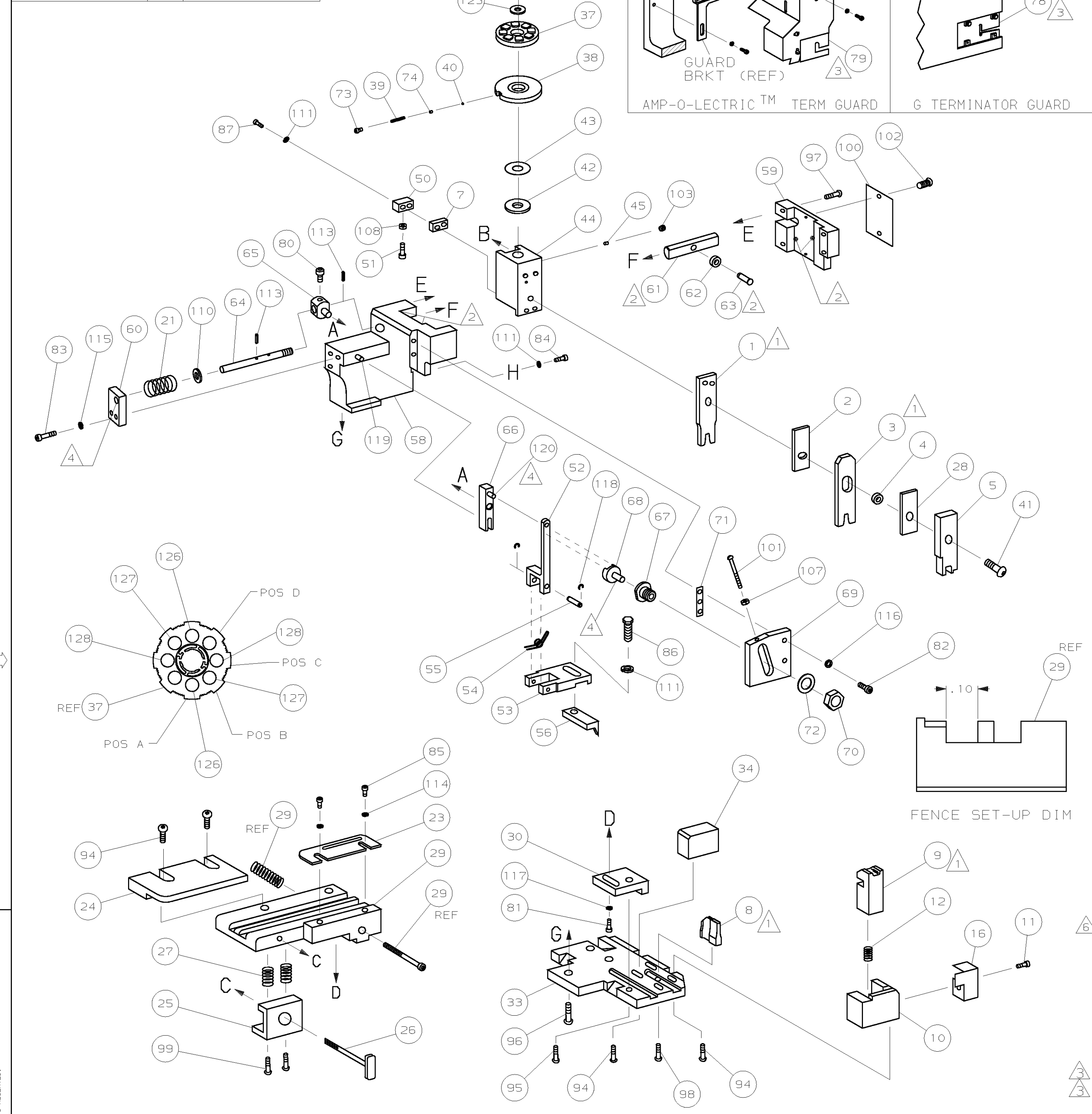

- 1 RECOMMENDED SPARE PARTS.
- 2 GREASE LIGHTLY.
- 3 GUARD MUST BE IN PLACE WHEN OPERATING APPLICATOR IN A BENCH MACHINE.
- 4 LUBRICATE DAILY USING NO. 20 MACHINE OIL.
- 5. ITEMS WITH QTY OF REF SPECIFIED (EXCEPT ITEMS 78 AND 79) ARE USED ON ITEM 46.
- 6 CUT TO LENGTH AT ASSY
- 7 FEED ADJUSTMENT REQUIRED WHEN SWITCHING TERMINALS. 962848 .511 FEED, 962854 .563 FEED

ST IFTKONTAKT		BUSHENKONTAKT		CRIMP DATA (AMP TERMINAL)		
962848		962854		PAD LTR	CRIMP HEIGHT	WIRE SIZE
				A	.040 ±.002 [1.02 ±0.05mm]	.35mm ²
				B	.038 ±.002 [.97 ±0.05mm]	.25mm ²
				C	.037 ±.002 [.95 ±0.05mm]	.20mm ²
				D	NOT	USED
				CRIMP	SIZE	TYPE
				WIRE	.062 [1.57mm]	F
				INSUL	.090 [2.29mm]	OV
						1.1 - 1.4 MM
WIRE STRIP LENGTH	TERM APPL	SPEC	FEED	APPL INSTRUCTION	SET UP GAGE	LAYOUT
.156-.188	NONE			408-8040	458637-1	L2195

QTY	REF	REF	REF	REF	REF	DESCRIPTION	ITEM NO
2	2	2	-	C	5-354779-0	PIN, WIRE DISC (.3240)C	129
2	2	2	-	C	4-354779-8	PIN, WIRE DISC (.3230)B	127
2	2	2	-	C	4-354779-3	PIN, WIRE DISC (.3205)A	126
1	1	1	-	A	986950-1	WASHER, FLAT PRECISION	125
1	1	1	-	A	217238-1	GENERAL INSTRUCTION PACKAGE	124
1	1	1	-	-	4088040	SF APPL INST 408-8040	123
							122
							121
REF	REF	REF	-	A	1-21030-1	PIN, DOWEL (Ø.187x.50) LEVER	120
REF	REF	REF	-	A	1-21030-6	PIN, DOWEL (Ø.187x1.25) HOUSING	119
REF	REF	REF	-	A	21045-3	RING, RET "C" (Ø.187) FD FING PIN	118
1	1	1	-	A	21024-5	WASHER, LOCK (#10) ADJ BLOCK	117
REF	REF	REF	-	A	21024-5	WASHER, LOCK (#10) ADJ PLATE	116
REF	REF	REF	-	A	21024-5	WASHER, LOCK (#10) FEED GDE ROD	115
2	2	2	-	A	21024-2	WASHER, LOCK (#4) FRONT STP GUIDE	114
REF	REF	REF	-	A	5-21028-1	PIN, SLT 5PR (Ø.125x.50) ADJ ROD	113
							112
4	4	4	-	A	21024-4	WASHER, LOCK (#8) STRIPPER	111
REF	REF	REF	-	A	21899-4	WASHER, FLAT (Ø5/16) SCREW ADJ	110
							109
1	1	1	-	A	21018-5	NUT, HEX (NO. 6) HOLDDOWN	108
REF	REF	REF	-	A	21068-5	NUT, HEX (6-32) FEED ADJ	107
							106
							105
1	1	-	-	A	992031-1	PIN, CLEVIS	104
1	1	1	-	A	21009-2	SCR, SKT 5ET (1/4-20x.25 LW) RAM	103
2	2	2	-	A	21017-2	SCR, DRIVE (#2x.19) ID PLATE	102
REF	REF	REF	-	A	6-23715-5	SCR, PAN HD (6-32x1.50) FEED ADJ	101
1	1	1	-	B	461264-1	PLATE, IDENTIFICATION	100
2	2	2	-	A	3-21002-0	SCR, BHC (10-32x.88) DRAG	99
1	1	1	-	A	22733-8	SCR, BHC (8-32x.38 LW) ANVIL	98
REF	REF	REF	-	A	2-21002-9	SCR, BHC (10-32x.75) CAP	97
REF	REF	REF	-	A	2-22733-8	SCR, BHC (1/4-20x.62) HOUSING	96
REF	REF	REF	-	A	2-21002-7	SCR, BHC (10-32x.50) 56 ADJ BLOCK	95
6	6	6	-	A	2-21002-2	SCR, BHC (8-32x.50) TERM H DWN	94
							93
							92
1	1	1	-	A	1-21002-7	SCR, BHC (6-32x.38) CAM	91
							90
1	1	-	-	A	7-21000-9	SCR, SHC (4-40x.19) STRIPPER	89
							88
2	2	2	-	A	2-21000-9	SCR, SHC (8-32x.68) DEP-HOLD	87
1	1	1	-	A	2-22603-0	SCR, HEX HD (8-32x.31) FEED FINGER	86
2	2	2	-	A	1-21000-3	SCR, SHC (4-40x.25) F ST GUIDE	85
1	1	1	-	A	2-21000-7	SCR, SHC (8-32x.50) STRIPPER	84
REF	REF	REF	-	A	3-21000-7	SCR, SHC (10-32x.75) FEED ROD 6D	83
REF	REF	REF	-	A	3-21000-6	SCR, SHC (10-32x.62) FD ADJ BLK	82
1	1	1	-	A	3-21000-4	SCR, SHC (10-32x.38) 56 ADJ BL	81
REF	REF	REF	-	A	3-21000-4	SCR, SHC (10-32x.38) PIVOT BLK	80
-	REF	-	-	B	455749-1	GUARD, WINDOW	79
REF	-	-	-	B	679532-1	INSERT, GUARD	78
							77
							76
							75
1	1	1	-	A	690603-1	SPRING, ASSIST	74
1	1	1	-	A	23030-1	SCR, SHC (6-32x.25 SL) INS DISC	73
REF	REF	REF	-	A	458109-1	WASHER, SPECIAL	72
REF	REF	REF	-	A	690517-1	SPACER	71
							70
							69
							68
							67
							66
							65
							64
							63
							62
							61
							60
							59
							58
							57
							56
							55
							54
							53
							52
							51
							50
							49
							48
							47
							46
							45
							44
							43
							42
							41
							40
							39
							38
							37
							36
							35
							34
REF	REF	REF	-	D	455675-1	PLATE, BASE	33
							32
							31
							30
1	1	1	-	C	318756-1	STRIP GUIDE PLATE ASSY	29
1	1	1	-	C	1-455888-6	SPACER, FRONT SHEAR DEP	28
2	2	2	-	A	1-22284-0	SPRING, DRAG	27
1	1	1	-	B	690546-1	LEVER, DRAG RELEASE	26
1	1	1	-	B	240792-1	DRAG, TERMINAL	25
1	1	1	-	D	1-90765-3	GUIDE, STRIP (REAR)	24
1	1	1	-	A	690438-1	GUIDE, STRIP (FRONT)	23
-	-	1	-	B	690472-2	STRIPPER	22
REF	REF	REF	-	A	4-22284-9	SPRING, FEED RETURN	21
1	1	-	-	A	679218-1	STRIPPER WIRE STOP ASSY	20
1	1	-	-	B	458949-1	STRIPPER	19
							18
							17
1	1	1	-	B	318563-1	GUARD, CHIP, FRONT	16
							15
							14
							13
1	1	1	-	A	5-22280-0	SPRING, SHEAR	12
1	1	1	-	B	690461-1	STOP, SHEAR	11
1	1	1	-	C	690459-1	HOLDER, SHEAR (FRONT)	10
1	1	1	-	C	462006-7	SHEAR, FLOAT (FRONT)	9
1	1	1	-	C	1-662184-2	ANVIL	8
1	1	1	-	C	2-240641-9	SPACER, DEPRESSOR (REAR)	7
							6
1	1	1	-	C	2-455889-0	DEPRESSOR, SHEAR (FRONT)	5
1	1	1	-	B	238011-4	SPACER, BLOCK CRIMPER	4
1	1	1	-	C	1-854830-4	CRIMPER, INSULATION	3
1	1	1	-	C	455888-6	SPACER, CRIMPER	2
1	1	1	-	C	1-456403-2	CRIMPER, WIRE	1

QTY	REF	REF	REF	REF	REF	DESCRIPTION	ITEM NO
-1						LEADMAKER	
-2						BENCH MODEL K	
-3						BENCH MODEL G	
REF	REF	REF	-	B	22594-8	NUT, HEX (1/2-20)	70
REF	REF	REF	-	B	240628-1	PLATE, ADJUSTMENT	69
REF	REF	REF	-	B	240626-1	SHAFT, PIVOT	68
REF	REF	REF	-	B	240633-1	BUSHING	67
REF	REF	REF	-	A	455680-1	LEVER, INTERMEDIATE	66
REF	REF	REF	-	B	240629-1	BLOCK, PIVOT	65
REF	REF	REF	-	A	240632-2	SCREW, ADJ FEED ROD	64
REF	REF	REF	-	B	240659-3	PIN, CAM ROLLER	63
REF	REF	REF	-	B	240658-1	ROLLER, CAM	62
REF	REF	REF	-	B	454398-2	ROD, FEED	61
REF	REF	REF	-	A	454178-1	GUIDE, FEED ROD	60
REF	REF	REF	-	C	454220-1	CAP, RAM	59
REF	REF	REF	-	D	454485-1	HOUSING	58
							57
1	1	1	-	B	1-694433-6	PAWL, FEED	56
REF	REF	REF	-	B	240624-1	PIN, FEED FINGER	55
REF	REF	REF	-	B	691499-1	SPRING, FEED FINGER	54
REF	REF	REF	-	B	690541-1	HOLDER, FEED FINGER	53
REF	REF	REF	-	A	455679-2	LEVER, TERMINAL FEED ARM	52
1	1	1	-	A	811242-2	BUMPER, HOLDDOWN	51
1	1	1	-	A	690753-1	SPACER, TONKER	50
1	-	-	-	B	690602-6	CAM, PRE-FEED 1 5/8 ST	49
-	1	-	-	B	690602-5	CAM, PRE-FEED 1 1/8 ST	48
-	-	1	-	B	690501-4	CAM, POST-FEED 1 5/8 ST	47
1	1	1	-	B	459456-2	APPLICATOR, BASIC (SUBASSY)	46
1	1	1	-	A	690191-1	PLUG, NYLON	45
1	1	1	-	C	455673-1	RAM	44
1	1	1	-	A	690125-1	WASHER, LAMINATED	43
1	1	1	-	A	690124-1	WASHER, RAM	42
1	1	1	-	A	7-21002-9	BOLT, CRIMPER (5/16x1.00)	41
1	1	1	-	A	23241-6	BALL, STEEL	40
1	1	1	-	A	690170-1	SPRING, COMPRESSION	39
1	1	1	-	C	690142-1	DISC, INSULATION	38
1	1	1	-	D	354777-1	WIRE DISC, PLASTIC	37
1	1	1	-	A	22480-5	WASHER, SPRING	36
1	1	1	-	B	690212-1	POST, RAM	35
1	1	1	-	B	2-690786-3	SUPPORT, TERMINAL	34
REF	REF	REF	-	D	455675-1	PLATE, BASE	33
							32
							31
REF	REF	REF	-	B	455689-1	BLOCK, STRIP GUIDE ADJ	30
1	1	1	-	C	318756-1	STRIP GUIDE PLATE ASSY	29
1	1	1	-	C	1-455888-6	SPACER, FRONT SHEAR DEP	28
2	2	2	-	A	1-22284-0	SPRING, DRAG	27
1	1	1	-	B	690546-1	LEVER, DRAG RELEASE	26
1	1	1	-	B	240792-1	DRAG, TERMINAL	25
1	1	1	-	D	1-90765-3	GUIDE, STRIP (REAR)	24
1	1	1	-	A	690438-1	GUIDE, STRIP (FRONT)	23
-	-	1	-	B	690472-2	STRIPPER	22
REF	REF	REF	-	A	4-22284-9	SPRING, FEED RETURN	21
1	1	-	-	A	679218-1	STRIPPER WIRE STOP ASSY	20
1	1	-	-	B	458949-		