



Chipsmall Limited consists of a professional team with an average of over 10 year of expertise in the distribution of electronic components. Based in Hongkong, we have already established firm and mutual-benefit business relationships with customers from,Europe,America and south Asia,supplying obsolete and hard-to-find components to meet their specific needs.

With the principle of “Quality Parts,Customers Priority,Honest Operation,and Considerate Service”,our business mainly focus on the distribution of electronic components. Line cards we deal with include Microchip,ALPS,ROHM,Xilinx,Pulse,ON,Everlight and Freescale. Main products comprise IC,Modules,Potentiometer,IC Socket,Relay,Connector.Our parts cover such applications as commercial,industrial, and automotives areas.

We are looking forward to setting up business relationship with you and hope to provide you with the best service and solution. Let us make a better world for our industry!



Contact us

Tel: +86-755-8981 8866 Fax: +86-755-8427 6832

Email & Skype: info@chipsmall.com Web: www.chipsmall.com

Address: A1208, Overseas Decoration Building, #122 Zhenhua RD., Futian, Shenzhen, China



PRODUCT NUMBER

SEE TABLE

68402-XXX-LF

- LEAD FREE OPTION
- PACKAGING OPTION NOTE 6. OMIT IF NOT REQUIRED
- NO OF POSITIONS PER ROW
- PLATING CODE
- BASE PART NUMBER

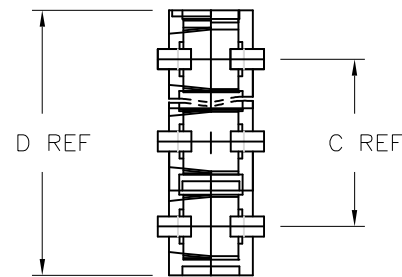
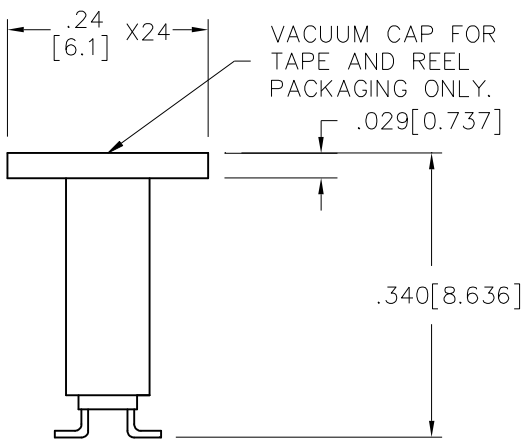
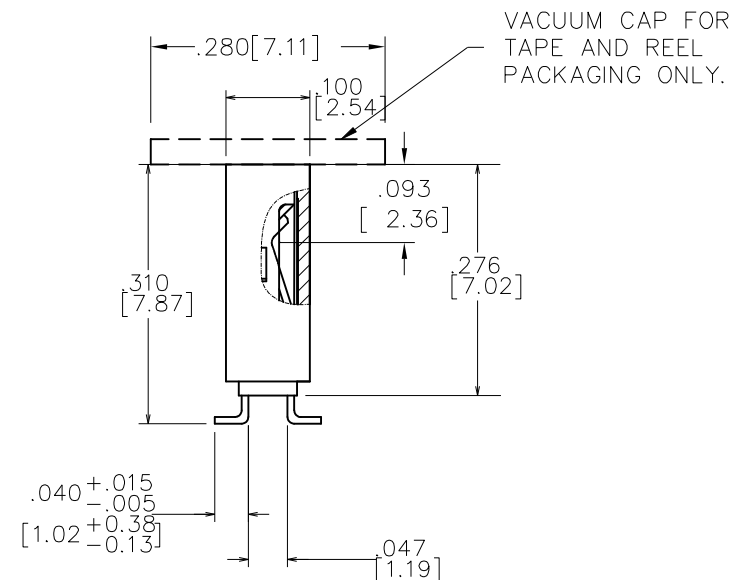
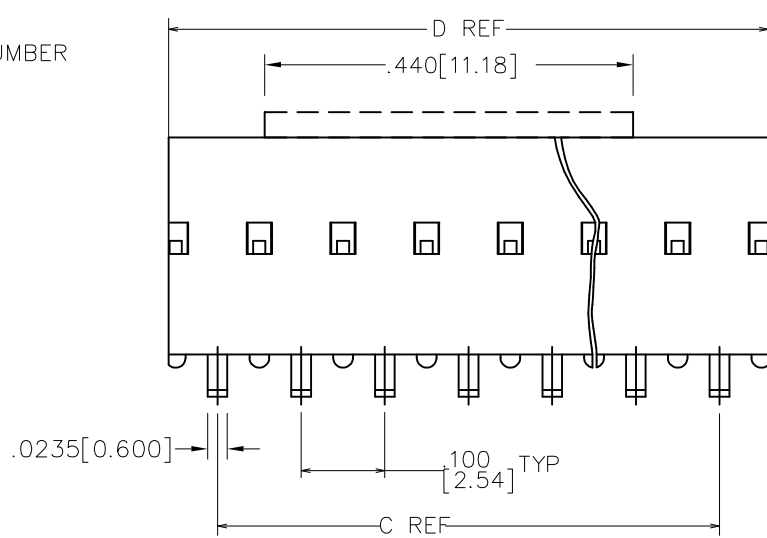

FIGURE 1
SMALL CAP FOR LESS THAN 6 POSITION

mat'l. code		surface ISO 1302 ✓		tolerance ISO 406 ISO 1101		projection INCH/MM		product family DUBOX	
ltr	ecn no	dr	date	tolerances unless otherwise specified				title DUBOX SURFACE MOUNT S/R VERTICAL CARD CONN	
U	M07-0198	MHT	04/24/07	angles	linear	.xx±01/.xx±3	scale 1:1		
V	ELX-N-17326	ZK	03/27/14			.xxx±0.005/.xxx±.13			
W	ELX-N-18094	Henry	06/26/14	0°±2°		.xxx±0.002/.xxx±.051			
X	ELX-N-26042	MZ	02/08/17	dr	J.SHREINER	11/07/90			
				enr	M.HAHN	11/07/90			
				chr	M.HAHN	11/07/90			
				appd	M.HAHN	11/07/90	dwg no 68402 sheet 1 of 5 size A3 type Product Customer Drawing		
sheet	revision	X	X	X	X	X			
index	sheet	1	2	3	4	5			

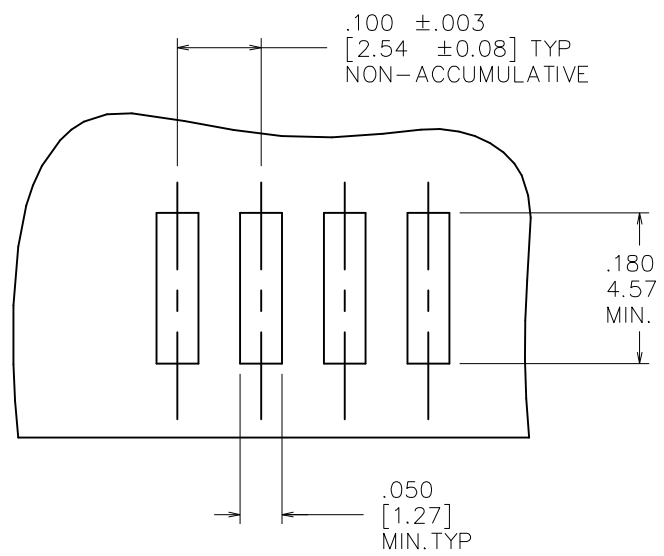

FIGURE A
TOP ENTRY
.025/.64 SQ PIN

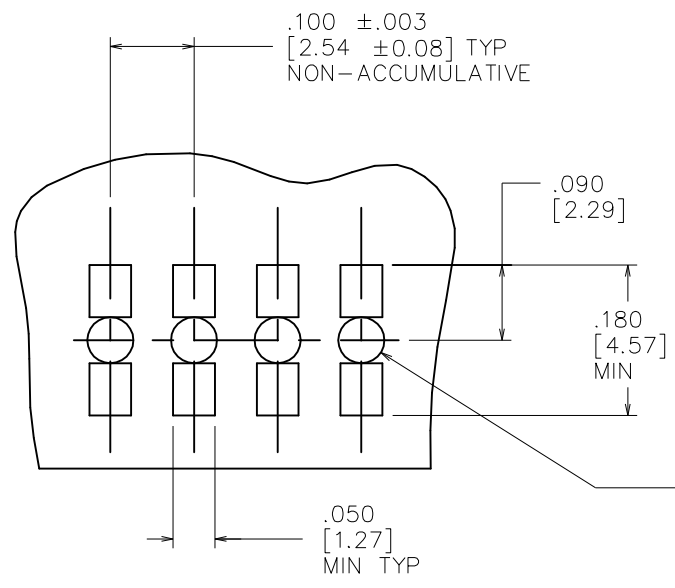

FIGURE B
BOTTOM ENTRY (THROUGH PWB)
.025/.64 SQ PIN

mat'l. code		surface ISO 1302 ✓		tolerance ISO 406 ISO 1101		projection ASME Y14.5		product family DUBOX	
ltr	ecn no	dr	date	tolerances unless otherwise specified		title		DUBOX SURFACE MOUNT S/R VERTICAL CARD CONN	
x				angles	linear	INCH/MM		dwg no 68402	
				0°±2°		scale 1:1		sheet 2 of 5 size A3	
		dr	J.SHREINER	11/07/90	Amphenol FCI		type Product Customer Drawing		
		enr	M.HAHN	11/07/90					
		chr	M.HAHN	11/07/90					
		appd	M.HAHN	11/07/90					
sheet	revision								
index	sheet								

1

2 3

4

5

6

PRODUCT NO NOTE 14	PLATING CONTACT AREA NOTE 16	PLATING SOLDER TAIL	MATERIAL REF.
68402-2XX	15u"/.38u Au OR GXT MIN OVER 50u"/1.27u NI MIN	100μ"/160μ" SN 2.54μ/4.06μ	NOTE 3 & 4
68402-3XX	30u"/.76u Au OR GXT MIN OVER 50u"/1.27u NI MIN	100μ"/160μ" SN 2.54μ/4.06μ	NOTE 3 & 4
68402-4XX	100u"/2.54u Sn MIN OVER 50u"/1.27u NI	100μ"/160μ" SN 2.54μ/4.06μ	NOTE 3 & 4
68402-6XX	30u"/.76u Au OR GXT MIN OVER 50u"/1.27u NI MIN	100μ"/160μ" SN 2.54μ/4.06μ	NOTE 3 & 4
68402-8XX	30u"/.76u Au MIN OVER 50u"/1.27u NI MIN	100μ"/160μ" SN 2.54μ/4.06μ	NOTE 3 & 4 — OBSOLETE



Amphenol
FCI

© 2016 AFCI

A

A

B

B

C

C

D

D

mat'l. code		surface ISO 1302 ✓	tolerance ISO 406 ISO 1101	projection 	product family DUBOX
ltr	ecn no	dr	date	tolerances unless otherwise specified	title
X				.xx±01/.x±3	DUBOX SURFACE MOUNT S/R
				angles linear .xxx±0.005/.xxx±.13	VERTICAL CARD CONN
				0°±2° .xxx±0.002/.xxx±.051	scale 1:1
		dr	J.SHREINER	11/07/90	dwg no 68402 sheet 3 of 5 size A3
		enr	M.HAHN	11/07/90	
		chr	M.HAHN	11/07/90	
		appd	M.HAHN	11/07/90	
sheet index	revision sheet				type Product Customer Drawing

1

2

5

6

PRODUCT NUMBER

SEE TABLE

VACUUM PICK-UP CAP
CENTRALLY LOCATED

DUBOX VERTICAL RECEPTACLE
DOUBLE ROW

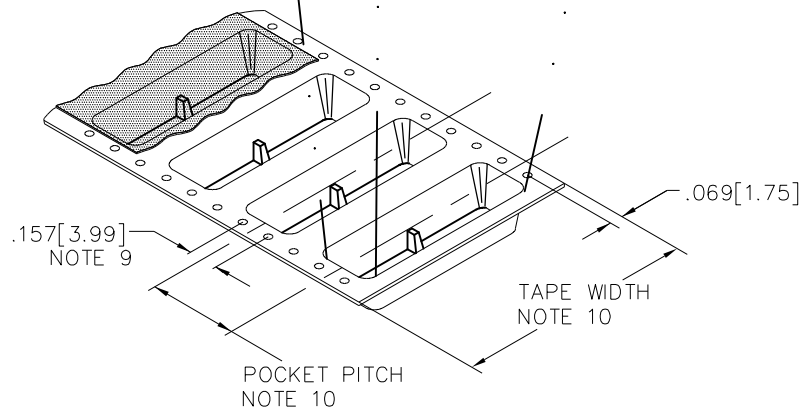
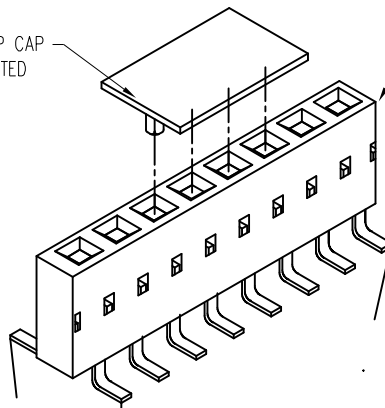

FIGURE 2
TAPE & REEL PACKAGING

NOTES:

- ①. TERMINAL MATERIAL: PHOSPHOR BRONZE. EXTRA HARD
2. RECOMMENDED APPLICATION DATA:
 - A. RECOMMENDED SOLDER PAD PATTERN IS SHOWN IN FIGURE A & B.
 - B. ALL MATING PINS TO BE .025/.64 SQUARE ON TRUE CENTER OF GIVEN TERMINAL SPACING. WITHIN .015/.38 DIA. (THERE IS A SPECIAL MATING PIN IS .016/.40. IT IS ONLY FOR P/N 68402-402WLF).
 - C. SUGGESTED MATING PIN LENGTH .210±.010 [5.33±.51]
- ③. HOUSING MATERIAL: P.P.S., FILLED. FLAME RETARDANT PER UL 94 V-0. THIS PART WILL WITHSTAND EXPOSURES TO 260°C PEAK TEMPERATURE FOR 20 SECONDS IN WAVE SOLDER, INFRA-RED OR VAPOR PHASE SOLDER PROCESS.
- ④. PRESTAMPED POST PLATED TERMINAL.
5. FCI, FCI PART NUMBER AND DATE CODE TO BE MARKED ON TUBE LABEL.
- ⑥. ADD SUFFIX 'P' TO DASH NUMBER AS FOURTH DIGIT FOR TAPE & REEL PACKAGING. ADD SUFFIX 'W' TO DASH NUMBER AS WITHOUT CAP ASSEMBLY FOR TAPE & REEL PACKAGING(IT IS CUSTOMIZED, WHICH HAS SPECIAL MATING PIN 0.016/.40 AND ONLY FOR SPECIAL P/N 68402-402WLF).
7. TAPE AND REEL PACKAGING PER GES-14-334.
- ⑧. VACUUM CAP MATERIAL: L.C.P, FLAME RETARDANT UL 94 V-0. COLOR: BLACK
- ⑨. TAPE AND REEL PACKAGING FOR 24mm WIDE AND BELOW HAVE PILOT HOLES ON ONE SIDE OF TAPE ONLY. SIZES ABOVE 24mm HAVE PILOT HOLES ON BOTH SIDES OF TAPE.
- ⑩. TAPE & REEL PACKAGING 32mm TAPE WIDTH, WITH 12mm POCKET PITCH.
- ⑪. MAXIMUM LENGTH OF CONNECTOR FOR TAPE AND REEL PACKAGING IS 2.50 INCHES LONG /63.5mm
- ⑫. PART NUMBER WITH "U" SUFFIX IS FOR SAWING PURPOSES ONLY.
13. STANDARD TUBE PACKAGE PER BUS-14-097/3.
- ⑭. ADD LF SUFFIX AT THE END OF PART NUMBER FOR LEAD FREE OPTION.
15. THIS PRODUCT MEETS EUROPEAN UNION DIRECTIVES AND OTHER COUNTRY REGULATION AS DESCRIBED IN GS-22-008.
- ⑯. PLATING OPTIONS: MAY BE EITHER GOLD OR GXT PLATED AT MANUFACTURER'S OPTION.

Amphenol FCI

© 2016 AFCI

mat'l. code		surface ISD 1302 ✓		tolerance ISO 206 ISO 1101		projection INCH/MM		product family DUBOX	
ltr		ecn no		dr		date		title DUBOX SURFACE MOUNT S/R VERTICAL CARD CONN	
x								scale 1:1	
		angles		linear				dwg no 68402	
		0°±2°						sheet 4 of 5 A3	
		dr		J.SHREINER		11/07/90		Amphenol FCI	
		enr		M.HAHN		11/07/90		type Product Customer Drawing	
		chr		M.HAHN		11/07/90			
		appd		M.HAHN		11/07/90			
sheet index		revision sheet							

A
 B
 C
 D

PRODUCT NO.	NO. OF POSITIONS	C DIM	D DIM	TAPE & REEL PACKAGING	LF OPTIONS
68402-Y02	1 X 2	.100/2.540	.217/5.511	NO	NOTE 14
-Y03	1 X 3	.200/5.080	.317/8.051	NO	
-Y04	1 X 4	.300/7.620	.417/10.591	NO	
-Y05	1 X 5	.400/10.160	.517/13.131	NO	
-Y06	1 X 6	.500/12.700	.617/15.671	NO	
-Y07	1 X 7	.600/15.240	.717/18.211	NO	
-Y08	1 X 8	.700/17.780	.817/20.751	NO	
-Y09	1 X 9	.800/20.320	.917/23.291	NO	
-Y10	1 X 10	.900/22.860	1.017/25.831	NO	
-Y11	1 X 11	1.000/25.400	1.117/28.371	NO	
-Y12	1 X 12	1.100/27.940	1.217/30.911	NO	
-Y13	1 X 13	1.200/30.480	1.317/33.451	NO	
-Y14	1 X 14	1.300/33.020	1.417/35.991	NO	
-Y15	1 X 15	1.400/35.560	1.517/38.531	NO	
-Y16	1 X 16	1.500/38.100	1.617/41.071	NO	
-Y17	1 X 17	1.600/40.640	1.717/43.611	NO	
-Y18	1 X 18	1.700/43.180	1.817/46.151	NO	
-Y19	1 X 19	1.800/45.720	1.917/48.691	NO	
-Y20	1 X 20	1.900/48.260	2.017/51.231	NO	
-Y21	1 X 21	2.000/50.800	2.117/53.771	NO	
-Y22	1 X 22	2.100/53.340	2.217/56.311	NO	
-Y23	1 X 23	2.200/55.880	2.317/58.851	NO	
-Y24	1 X 24	2.300/58.420	2.417/61.391	NO	
-Y25	1 X 25	2.400/60.960	2.517/63.931	NO	
68402-Y26	1 X 26	2.500/63.50	2.617/66.47	NO	
68402-Y26U	1 X 26	2.500/63.50	2.617/66.47	NO	
68402-Y06P	1 X 6	.500/12.700	.617/15.671	YES	
68402-Y27-Y50	---	---	---	NO	NOT AVAILABLE

NOTE 12
NOTE 6

Amphenol
 FCI

© 2016 AFCI

mat'l. code		surface ISO 1302 ✓		tolerance ISO 406 ISO 1101		projection 		product family DUBOX	
ltr		ecn no		dr		date		title	
x								DUBOX SURFACE MOUNT S/R VERTICAL CARD CONN	
		tolerances unless otherwise specified		linear		INCH/MM		sheet 5 of 5	
		.xx±01/.xx±3		.xxx±0.005/.xxx±.13		scale 1:1		68402	
		0°±2°		.xxxx±0.002/.xxx±.051		Amphenol FCI		type Product Customer Drawing	
		dr		J.SHREINER		11/07/90		size A3	
		enr		M.HAHN		11/07/90			
		chr		M.HAHN		11/07/90			
		appd		M.HAHN		11/07/90			
sheet		revision							
index		sheet							