



Chipsmall Limited consists of a professional team with an average of over 10 year of expertise in the distribution of electronic components. Based in Hongkong, we have already established firm and mutual-benefit business relationships with customers from,Europe,America and south Asia,supplying obsolete and hard-to-find components to meet their specific needs.

With the principle of “Quality Parts,Customers Priority,Honest Operation,and Considerate Service”,our business mainly focus on the distribution of electronic components. Line cards we deal with include Microchip,ALPS,ROHM,Xilinx,Pulse,ON,Everlight and Freescale. Main products comprise IC,Modules,Potentiometer,IC Socket,Relay,Connector.Our parts cover such applications as commercial,industrial, and automotives areas.

We are looking forward to setting up business relationship with you and hope to provide you with the best service and solution. Let us make a better world for our industry!



## Contact us

Tel: +86-755-8981 8866 Fax: +86-755-8427 6832

Email & Skype: info@chipsmall.com Web: www.chipsmall.com

Address: A1208, Overseas Decoration Building, #122 Zhenhua RD., Futian, Shenzhen, China



PRODUCT NUMBER  
SEE TABLE

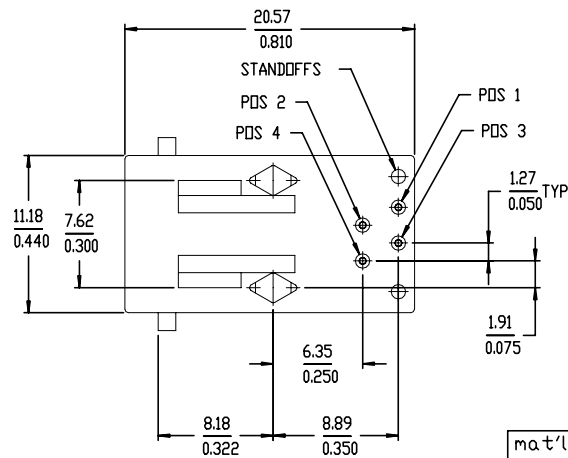
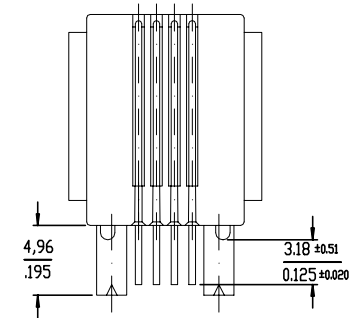
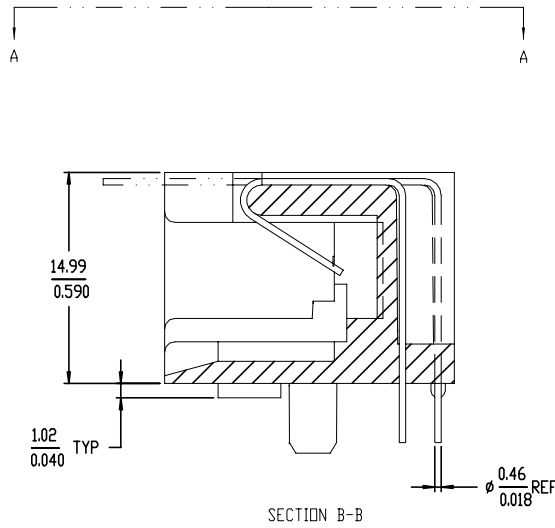
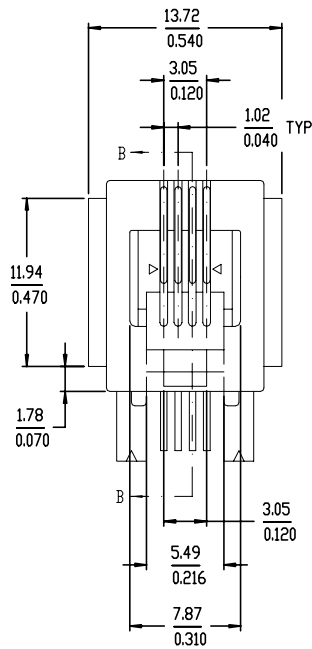

mat'l. code			surface ISO1302 ✓		tolerance ISO1101 ISO406		projection mm		product family MOD JACK		
ltr ecn nodr date			tolerances unless otherwise specified		scale 2.0		title		4 POS HORIZONTAL PC.B. MOD JACK ASSY		
J	S80281	BL	12/18/98	angle	0.X±0.3	mm		dwg no		sheet 1 of 2	size
K	S00022	BL	26/01/00	0°±2'	0.XX±0.15	scale 2.0		68897		A4	
L	M05-0067	MHT	4/8/05	enr	0.XXX±0.05	FCI		Product		Customer	Drawing
M	M05-0155	MHT	6/29/05	chr	M.HERNANDEZ	4/8/05	type				
N	ELX-N-010698	SH MMD	3/14/12	appd	M.BARRIOS	4/8/05					
sheet index	revision	N	N								
	sheet	1	2								

PRODUCT NO. NOTE 1,3	POSITIONS LOADED	CONTACT PLATING NOTE 6	HOUSING COLOR
68897-001	ALL	5u" Au + high performance lubricant	BLACK
-002	ALL	5u" Au + high performance lubricant	BLACK
-003	ALL	5u" Au + high performance lubricant	OFF-WHITE
-004	ALL	1,27um / 50u" GXT	BLACK
-005	ALL	0.15um / 6u" AU	BLACK

⑤

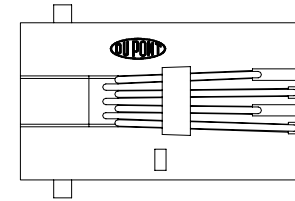

VIEW A-A

RECOMMENDED BOARD LAYOUT  
VIEWED FROM TOP

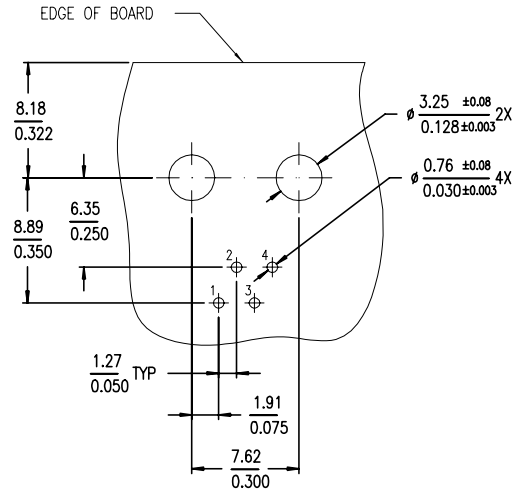

NOTES :

- WHEN PRODUCT CALLS FOR PACKAGING IN TRAY ORDER THE PRODUCT WITH PART NUMBER 68897-XXXX FOR PACKAGING IDENTIFICATION. FOR PRODUCT NUMBER WITHOUT SUFFIX "T", THE PRODUCT WILL BE PACKED IN TUBE AS PER DUPONT STANDARD PACKAGING.
- ADD "LF" SUFFIX AT THE END OF PART NUMBER FOR LEAD FREE OPTION.
- THIS PRODUCT MEETS EUROPEAN UNION DIRECTIVES AN OTHER COUNTRY REGULATION AS DESCRIBED IN GS-22-008.
- THE HOUSING TEMPERATURE WITHSTAND EXPOSURE TO 260°C PEAK TEMPERATURE FOR 15 SECONDS IN A WAVE SOLDER APPLICATION WITH A 1.5 MM MINIMUM THICK CIRCUIT BOARD. SEE APPLICATION NOTES/PROCEDURES IF THEY ARE AVAILABLE.
- PLATING OPTION:  
MAY BE EITHER GOLD OR GXT PLATED AT MANUFACTURER'S OPTION.

mat'l. code		surface ISO1302 ✓		tolerance ISO1101 ISO406		projection mm		product family MOD JACK		
l trechn nodr		date		tolerances unless otherwise specified		scale 2.0		title		
J	S80281 BL	12/18/98	angle	0.X±0.3				4 POS HORIZONTAL		
K	S00022 BL	26/01/00	0°±2'	0.XX±0.15				PC.B. MOD JACK ASSY		
L	M05-0067 MHT	4/8/05		0.XXX±0.05				dwg no		
M	M05-0155 MHT	6/29/05	dr	M.HERNANDEZ	4/8/05	FCI	sheet 2 of 2	size		
N	ELX-N-010698 SH MM	3/14/12	enr	M.BARRIOS	4/8/05			68897		A4
			chr	M.BARRIOS	4/8/05			type		Product Customer Drawing
			appd	M.BARRIOS	4/8/05					
sheet index	revision sheet									