



Chipsmall Limited consists of a professional team with an average of over 10 year of expertise in the distribution of electronic components. Based in Hongkong, we have already established firm and mutual-benefit business relationships with customers from,Europe,America and south Asia,supplying obsolete and hard-to-find components to meet their specific needs.

With the principle of “Quality Parts,Customers Priority,Honest Operation,and Considerate Service”,our business mainly focus on the distribution of electronic components. Line cards we deal with include Microchip,ALPS,ROHM,Xilinx,Pulse,ON,Everlight and Freescale. Main products comprise IC,Modules,Potentiometer,IC Socket,Relay,Connector.Our parts cover such applications as commercial,industrial, and automotives areas.

We are looking forward to setting up business relationship with you and hope to provide you with the best service and solution. Let us make a better world for our industry!



Contact us

Tel: +86-755-8981 8866 Fax: +86-755-8427 6832

Email & Skype: info@chipsmall.com Web: www.chipsmall.com

Address: A1208, Overseas Decoration Building, #122 Zhenhua RD., Futian, Shenzhen, China



THIS IS A C.A.D. GENERATED DRAWING
DO NOT MAKE MANUAL REVISIONS TO MASTER.

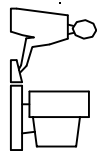

ISSUE NUMBER
REMOVE P/N: 690-009-221-013
R.STA.MONICA MAY.07/10 (7)
ADD P/N: 690-009-521T013 AND 690-009-621T013
R.STA.MONICA JUN.01/10 (8)
690-009-521-313 WAS 690-009-521T013 AND 690-009-621-313 WAS 690-009-621T013. ADD TAPE & REEL AND PCB TOLERANCE R.STA.MONICA JUN.07/10
ADD POSITION NOS. AT PCB LAYOUT
F.BRONES MAY.11/2012 (10)
300PCS WAS 350PCS/REEL R.STA.MONICA NOV.20/2014 (11)
UPDATE DRAWING (12)

SPECIFICATION:

CONTACT CURRENT RATING: 1.8 A PER PIN MIN. AT 25°C (STILL AIR)
INSULATION RESISTANCE: 100 MEGOHMS MIN. AT DC FOR 1 MINUTE
DWV: 100 VAC FOR 1 MINUTE
LOW LEVEL CONTACT RESISTANCE: 50 MILLIOMHS MAX.
INSERTION FORCE: 3.57 KG.(35N) MAX.
EXTRACTION FORCE: 1.02 KG.(10N) MIN. FOR INITIAL
OPERATING TEMPERATURE: -30°C TO +85°C

MATERIALS:

SHELL: BRASS, NICKEL PLATED
CONTACTS: PHOSPHOR BRONZE, PLATED WITH 15 MICRONS OF GOLD
ON CONTACT AREA, TIN ON TAIL OVER NICKEL.
INSULATORS: PBT, UL94V-0, BLUE COLOR (PANTONE 300C)

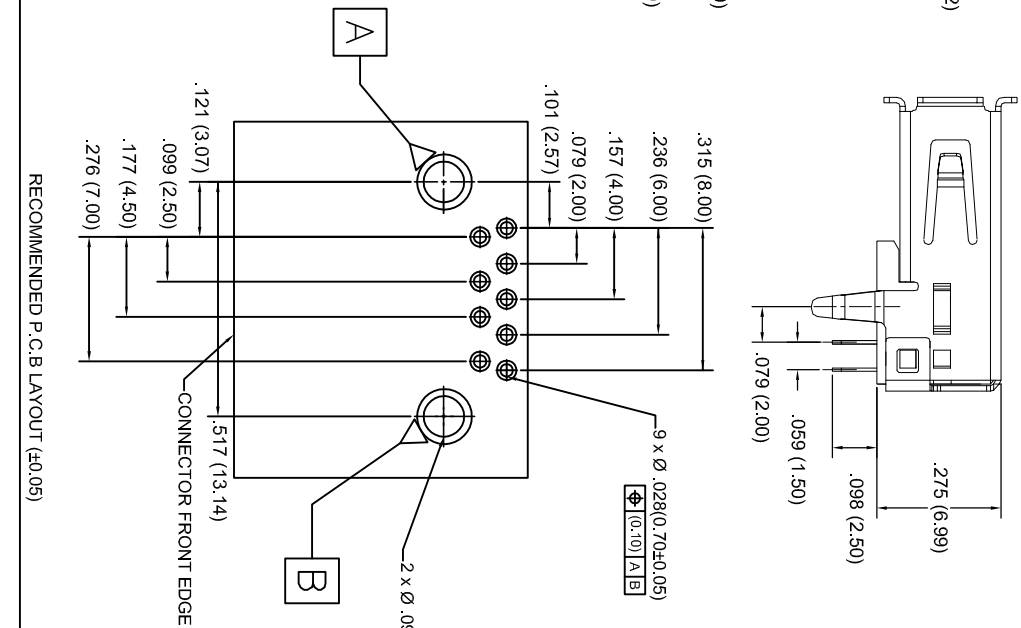
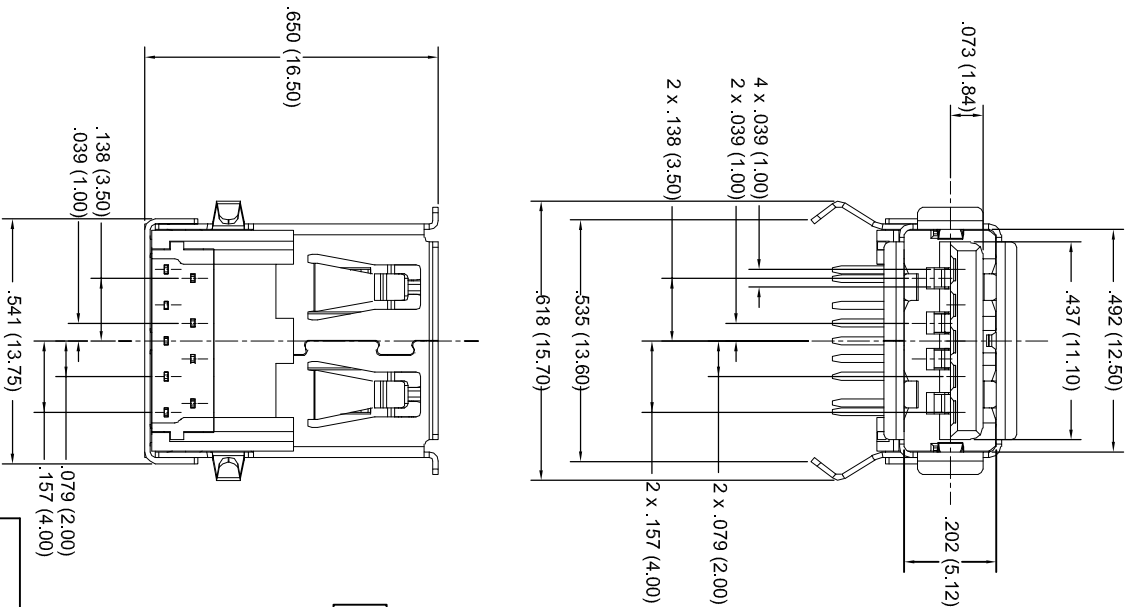

RECOMMENDED P.C.B LAYOUT (±0.05)

PART NUMBERS	GOLD PLATING	PACKAGING DETAIL
690-009-521-013	15 u" OF GOLD	TAPE AND REEL
690-009-521-313	15 u" OF GOLD	PLASTIC TRAY
690-009-621-013	30 u" OF GOLD	TAPE AND REEL
690-009-621-313	30 u" OF GOLD	PLASTIC TRAY



THIS SERIES FULLY CONFORMS TO THE
EUROPEAN UNION DIRECTIVES 2002/95/EC
AND 2002/96/EC FOR ROHS COMPLIANCY.

USB-A RECEPTACLE 90° DIP, 3.0 VERSION

ACAD REFERENCE NO. 690-009-521-013

DRAWN: C.B DATE: AUG.16/16

PART NUMBER
SEE ABOVE

SHEET 1 OF 3

DRAWING NUMBER
690-009-521-013

ISSUE
12

NOTE:

TOLERANCE FOR ALL DIMENSIONS IS ±.006 (±0.15),
UNLESS OTHERWISE SPECIFIED

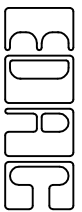

EDAC INC
TORONTO, ONTARIO
CANADA

YOUR CONNECTION TO QUALITY & SERVICE

THESE DRAWINGS AND SPECIFICATIONS
ARE THE PROPERTY OF EDAC INC. AND
SHALL NOT BE REPRODUCED OR COPIED
OR USED AS THE BASIS FOR THE
MANUFACTURE OR SALE OF APPARATUS
WITHOUT WRITTEN PERMISSION.

THIS IS A C.A.D. GENERATED DRAWING
DO NOT MAKE MANUAL REVISIONS TO MASTER.

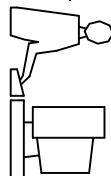

ISSUE NUMBER
SEE PAGE 1 OF 3
12

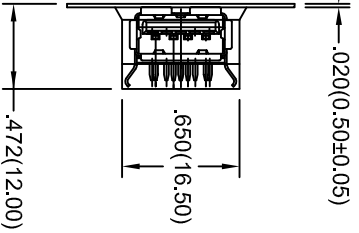
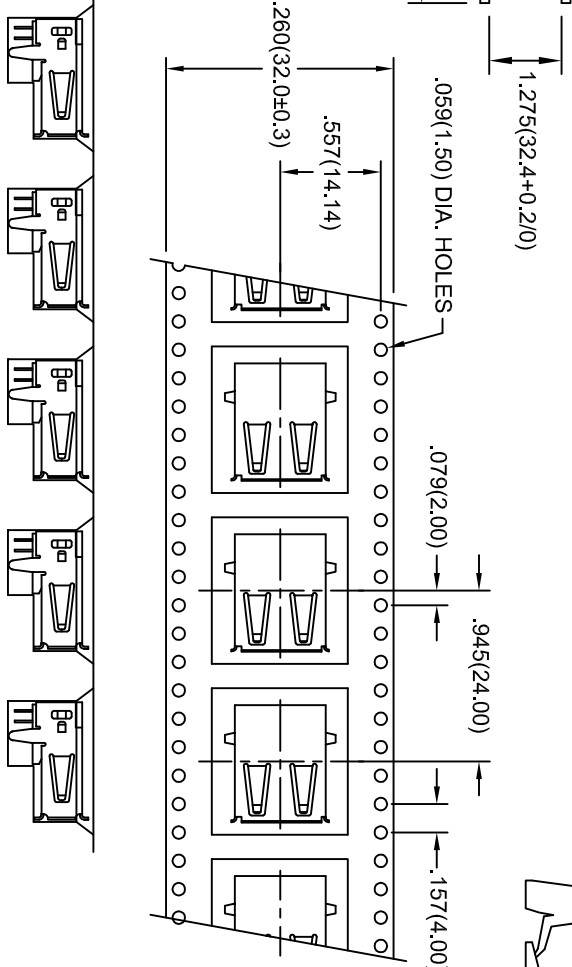
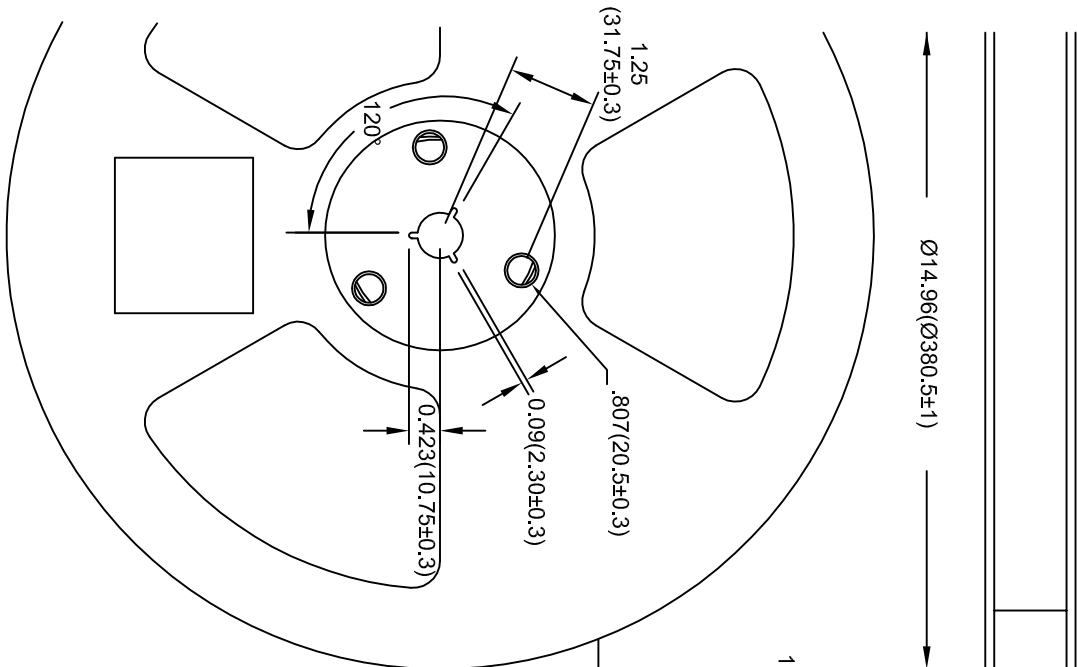

NOTE:
TOLERANCE FOR ALL DIMENSIONS IN MM IS ±0.1, UNLESS OTHERWISE SPECIFIED

**USB-A RECEPTACLE 90° DIP, 3.0 VERSION
PACKAGING REEL (300 PCS PER REEL)**

EDAC INC
TORONTO, ONTARIO
CANADA
YOUR CONNECTION TO QUALITY & SERVICE

THESE DRAWINGS AND SPECIFICATIONS
ARE THE PROPERTY OF EDAC INC. AND
SHALL NOT BE REPRODUCED OR COPIED
OR USED AS THE BASIS FOR THE
MANUFACTURE OR SALE OF APPARATUS
WITHOUT WRITTEN PERMISSION.

ACAD REFERENCE NO.	690-009-521-013
DRAWN:-	DATE: -
PART NUMBER	SEE PAGE 1 OF 3
DRAWING NUMBER	690-009-521-013
	SHEET 2 OF 3
	ISSUE
	12

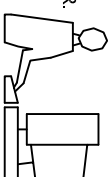

11.023 [280.0]

0.401 [10.2]

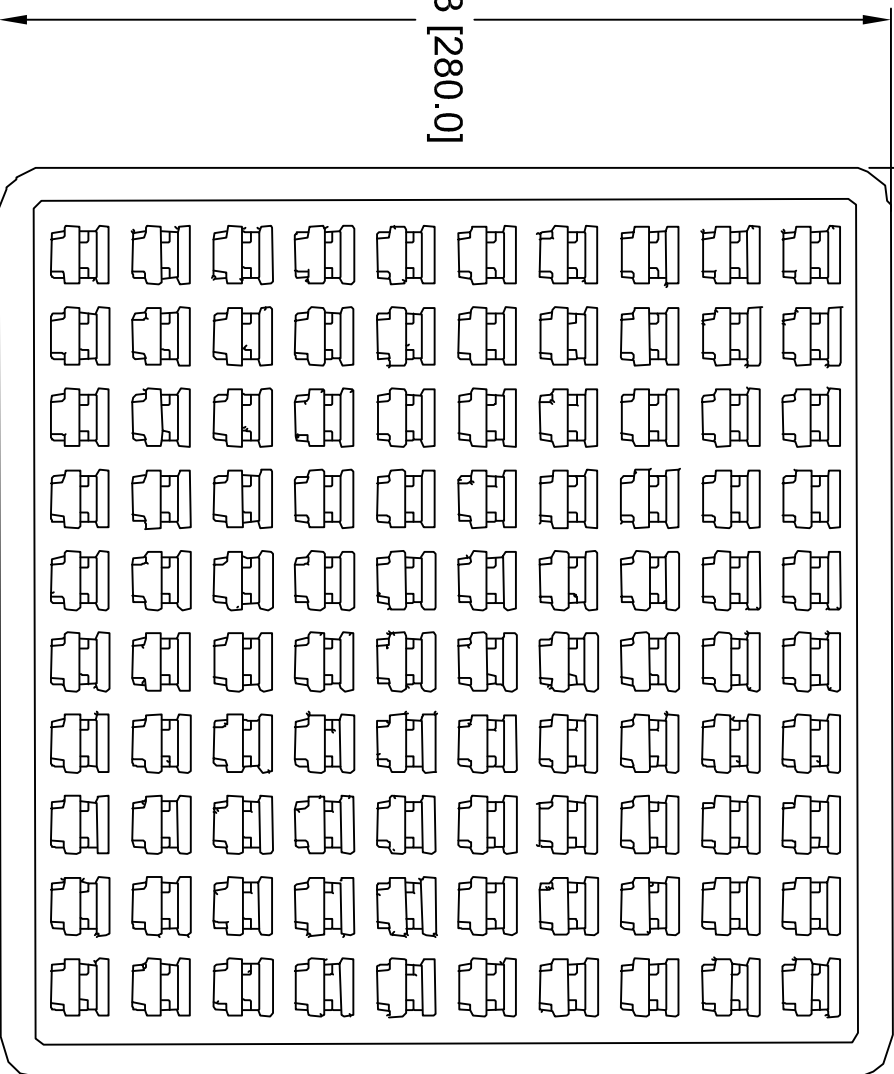

NOTES:

1. MATERIAL: TRANSPARENT PVC
2. THICKNESS: 0.20 ± 0.05MM
3. PCS / TRAY : 100PCS
4. TRAY / BOX : 25TRAYS
5. PCS / BOX : 2500PCS
6. CARTON SIZE:
300MM x 300MM x 265MM

USB-A RECEPTACLE 90° DIP, 3.0 VERSION
TRAY PACKAGING (100 PCS PER TRAY)

EDAC INC
TORONTO, ONTARIO
CANADA
YOUR CONNECTION TO QUALITY & SERVICE

THESE DRAWINGS AND SPECIFICATIONS
ARE THE PROPERTY OF EDAC INC. AND
SHALL NOT BE REPRODUCED OR COPIED
OR USED AS THE BASIS FOR THE
MANUFACTURE OR SALE OF APPARATUS
WITHOUT WRITTEN PERMISSION.

ACAD REFERENCE NO. 690-009-521-013

DRAWN: - DATE: -

PART NUMBER

SEE PAGE 1 OF 3

SHEET 3 OF 3

DRAWING NUMBER

690-009-521-013

ISSUE

12