



Chipsmall Limited consists of a professional team with an average of over 10 year of expertise in the distribution of electronic components. Based in Hongkong, we have already established firm and mutual-benefit business relationships with customers from,Europe,America and south Asia,supplying obsolete and hard-to-find components to meet their specific needs.

With the principle of “Quality Parts,Customers Priority,Honest Operation,and Considerate Service”,our business mainly focus on the distribution of electronic components. Line cards we deal with include Microchip,ALPS,ROHM,Xilinx,Pulse,ON,Everlight and Freescale. Main products comprise IC,Modules,Potentiometer,IC Socket,Relay,Connector.Our parts cover such applications as commercial,industrial, and automotives areas.

We are looking forward to setting up business relationship with you and hope to provide you with the best service and solution. Let us make a better world for our industry!



Contact us

Tel: +86-755-8981 8866 Fax: +86-755-8427 6832

Email & Skype: info@chipsmall.com Web: www.chipsmall.com

Address: A1208, Overseas Decoration Building, #122 Zhenhua RD., Futian, Shenzhen, China



TOLERANCE UNLESS OTHERWISE SPECIFIED IN MM: 0 ±0.2 0.00 ±0.1 0.000 ±0.005

ANGLE 1°

THIS IS A C.A.D. GENERATED DRAWING DO NOT MAKE MANUAL REVISIONS TO MASTER.

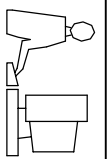

ISSUE NUMBER	ADD PACKAGING SPECS	ADD NOTE 3: O-RING	ADD NOTE 4: TUBE PACKAGING PART NO.	UPDATE GASKET TO SINGLE POINT O-RING
②	R.STA.MONICA SEPT.16/2014	R.STA.MONICA MAY.20/2015	R.STA.MONICA MAY.20/2015	R.STA.MONICA SEPT.26/2016
③				
④				
⑤				

MOUNTING LAYOUT

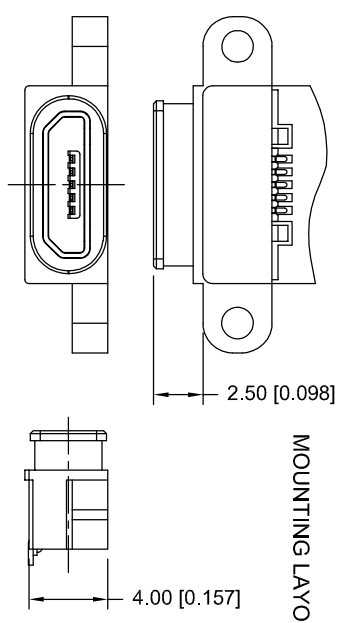

MATING LAYOUT

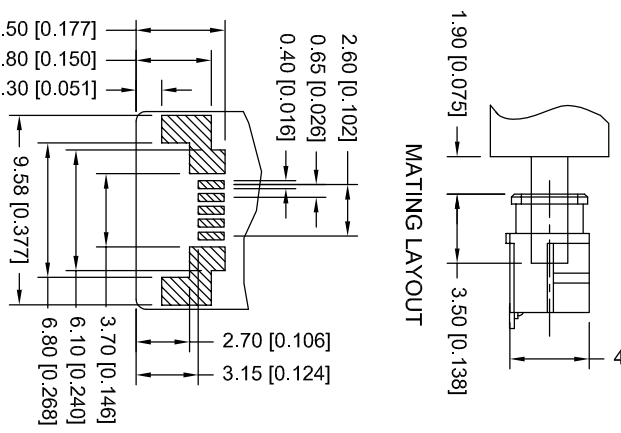

GASKET INTEGRATION LAYOUT

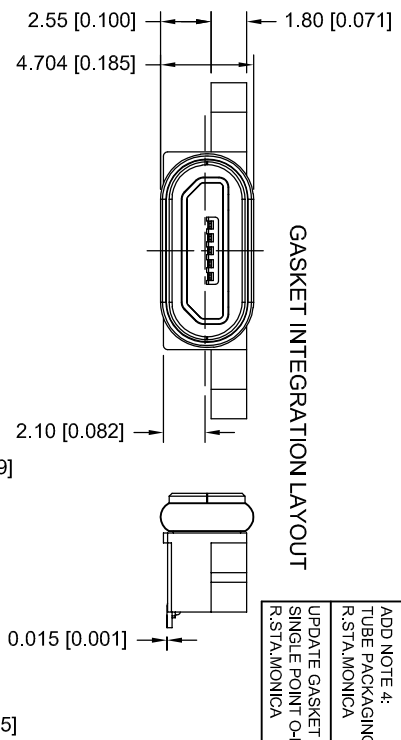

PANEL MOUNTING LAYOUT

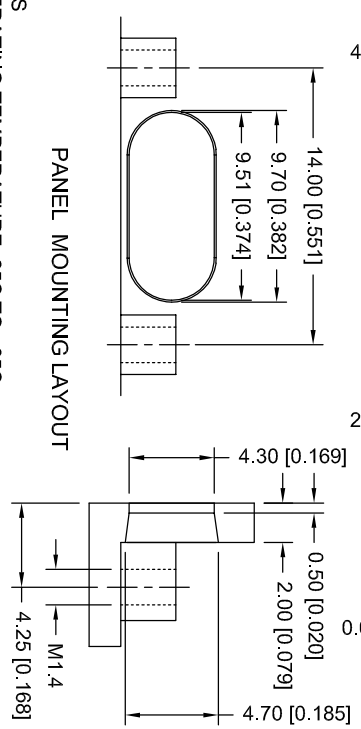

- NOTES**
- OPERATING TEMPERATURE:-25C TO +85C
 - MATERIALS:**
INSULATOR: LCP, UL94 V-0, COLOR: BLACK
CONTACT: PHOSPHOR BRONZE, WITH 10 µIN OF GOLD PLATING ON CONTACT AREA, AND GOLD FLASH ON SOLDER AREA OVER NICKEL UNDERPLATING
SHELL: STAINLESS STEEL, WITH MATTE TIN PLATING
PAD: BRASS, WITH MATTE TIN PLATING
 - MATCH WITH O-RING PART NO. M00-556-001
 - PART NO:**
690-W05-290-483
690-W05-290-783
- PACKAGING**
TAP AND REEL PACKAGING
TUBE PACKAGING (200PCS PER TUBE)

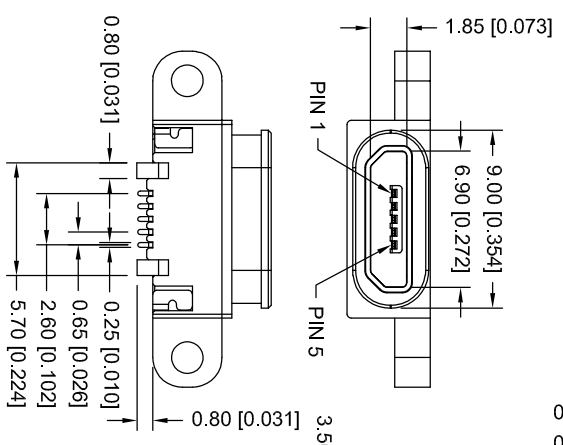

WATERPROOF MICRO USB 5P(F) SMT TYPE



THIS SERIES FULLY CONFORMS TO THE EUROPEAN UNION DIRECTIVES 2002/95/EC AND 2002/96/EC FOR ROHS COMPLIANCY.

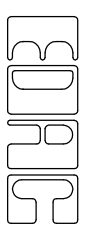

EDAC INC
TORONTO, ONTARIO
CANADA

YOUR CONNECTION TO QUALITY & SERVICE

THESE DRAWINGS AND SPECIFICATIONS ARE THE PROPERTY OF EDAC INC. AND SHALL NOT BE REPRODUCED OR COPIED OR USED AS THE BASIS FOR THE MANUFACTURE OR SALE OF APPARATUS WITHOUT WRITTEN PERMISSION.

ACAD REFERENCE NO.: 690-W05-290-483	
DRAWN: R.STA.MONICA	DATE: JAN.20/2014
CHECKED:	DATE:
PART NUMBER	
SEE PART NO.	SHEET 1 OF 2
DRAWING NUMBER	ISSUE
690-W05-290-483	5

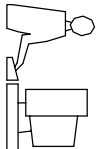

THIS IS A C.A.D. GENERATED DRAWING
DO NOT MAKE MANUAL REVISIONS TO MASTER.

TOLERANCE UNLESS OTHERWISE
SPECIFIED IN MM:
0 ±0.2
0.00 ±0.1
0.000 ±0.05

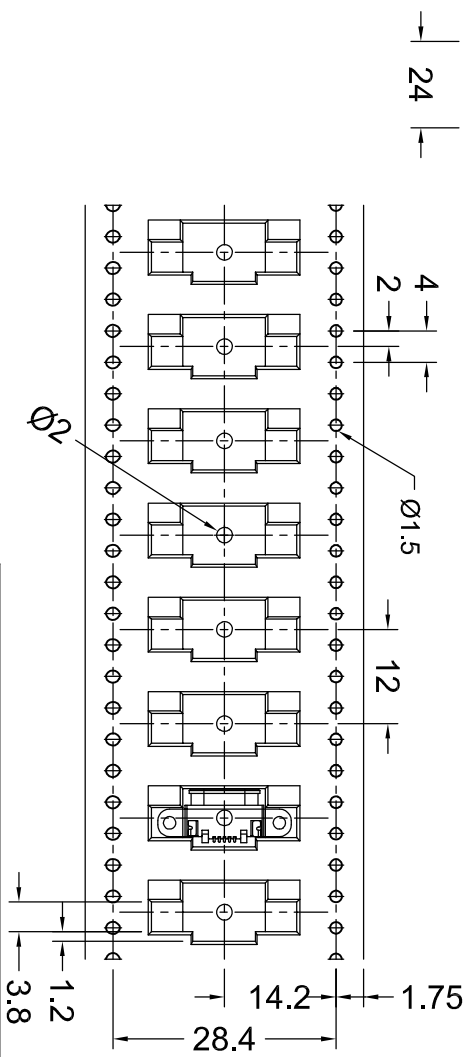
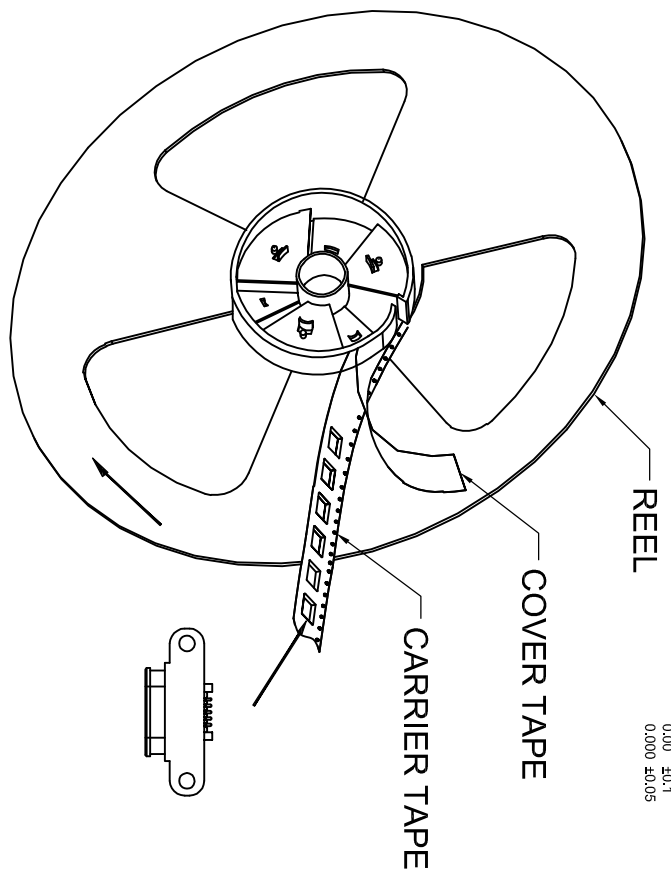

QUANTITY PER REEL: 1100 PCS

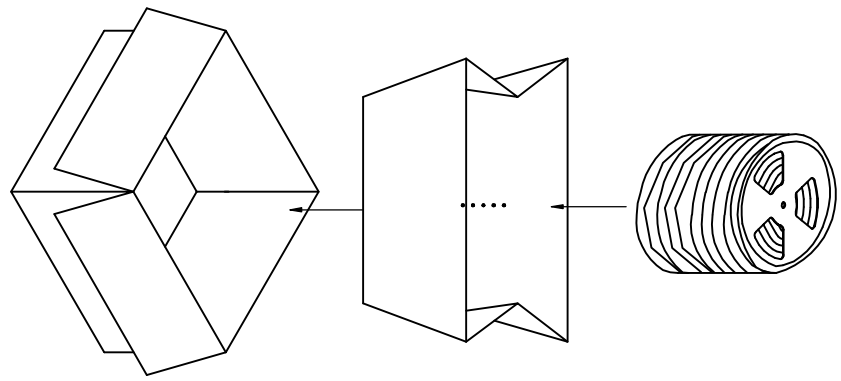

**WATERPROOF MICRO USB 5P(F) SMT TYPE
TAPE & REEL PACKAGING SPECS**

ACAD REFERENCE NO.:	690-W05-290-483
DRAWN:	R.STA.MONICA
DATE:	SEPT.16/2014
CHECKED:	DATE:
PART NUMBER	
SEE PART NO.	SHEET 2 OF 2
DRAWING NUMBER	
690-W05-290-483	ISSUE
	5

EDAC INC
TORONTO, ONTARIO
CANADA

EDAC INC
TORONTO, ONTARIO
CANADA

YOUR CONNECTION TO QUALITY & SERVICE



THIS SERIES FULLY CONFORMS TO THE
EUROPEAN UNION DIRECTIVES 2002/95/EC
AND 2002/96/EC FOR ROHS COMPLIANCY.

THESE DRAWINGS AND SPECIFICATIONS
ARE THE PROPERTY OF EDAC INC. AND
SHALL NOT BE REPRODUCED OR COPIED
OR USED AS THE BASIS FOR THE
MANUFACTURE OR SALE OF APPARATUS
WITHOUT WRITTEN PERMISSION.