



Chipsmall Limited consists of a professional team with an average of over 10 year of expertise in the distribution of electronic components. Based in Hongkong, we have already established firm and mutual-benefit business relationships with customers from,Europe,America and south Asia,supplying obsolete and hard-to-find components to meet their specific needs.

With the principle of “Quality Parts,Customers Priority,Honest Operation,and Considerate Service”,our business mainly focus on the distribution of electronic components. Line cards we deal with include Microchip,ALPS,ROHM,Xilinx,Pulse,ON,Everlight and Freescale. Main products comprise IC,Modules,Potentiometer,IC Socket,Relay,Connector.Our parts cover such applications as commercial,industrial, and automotives areas.

We are looking forward to setting up business relationship with you and hope to provide you with the best service and solution. Let us make a better world for our industry!



Contact us

Tel: +86-755-8981 8866 Fax: +86-755-8427 6832

Email & Skype: info@chipsmall.com Web: www.chipsmall.com

Address: A1208, Overseas Decoration Building, #122 Zhenhua RD., Futian, Shenzhen, China



PRODUCT NO.

SEE TABLE

69154 - XXX - LF

- └ LEAD FREE OPTION
- └ PACKAGING OPTION NOTE 10, OMIT IF NOT REQUIRED.
- └ NO. OF POSITIONS PER ROW
- └ PLATING CODE
- └ BASE PART NUMBER

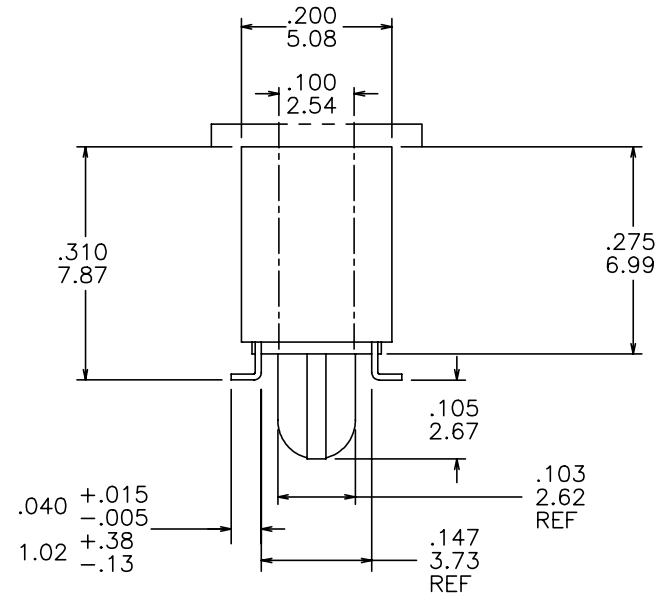
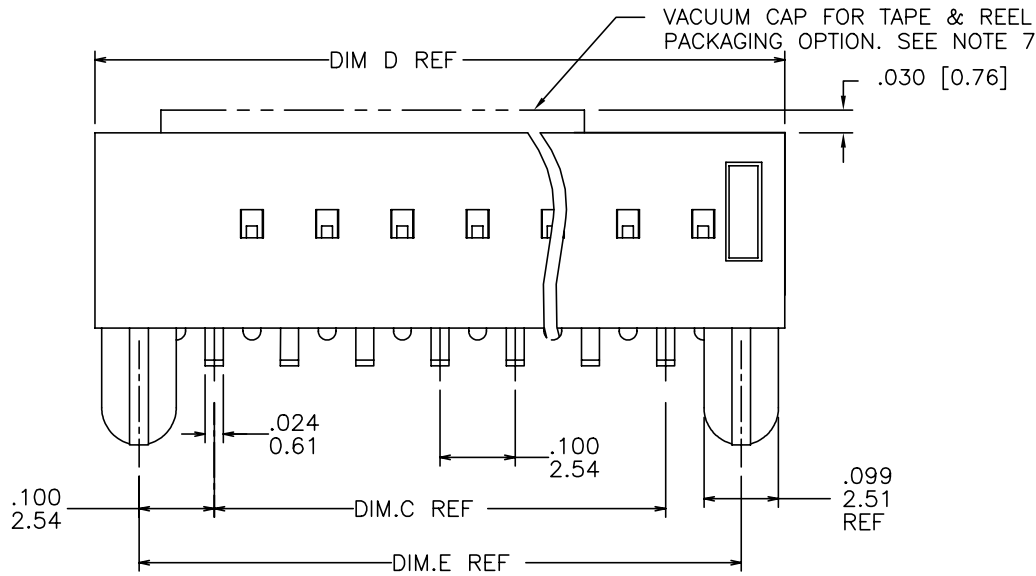
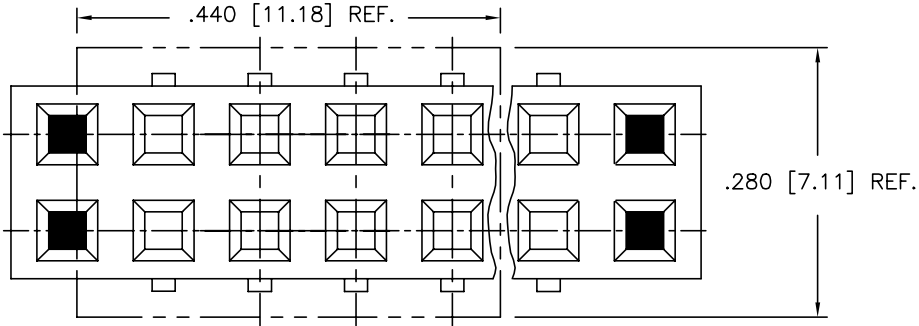

mat'l. code		surface		tolerance		projection		product family	
NOTES 1,3,10 & 14		ISO 1302 ✓		ISO 406 ISO 1101				DUBOX	
l	tr	ec	n	nd	r	date		title	
M	ELX-N-14890	ZK	06/03/13	tolerances unless otherwise specified				SMT DOUBLE ROW VCC ASSEMBLY	
		angles		line		INCH/MM			
		.XX±.01/.XX±.3		.XXX±.0.005/.XX±.13		scale 1:1			
P	V03-0310	HTB	05/02/03	0°±2'					
R	V03-1246	PJ	12/04/03	dr	J. SHREINER	12/31/90		dwg no sheet 1 of 6 size	
S	V05-0463	DPU	06/27/05	engr	M. HAHN	12/31/90		69154 A3	
T	M07-0143	ERE	03/03/07	chr	M. HAHN	12/31/90		type Product Customer Drawing	
U	M07-0203	AGS	05/02/07	appd	M. HAHN	12/31/90			
sheet	revision	V	V	V	V	V	V		
index	sheet	1	2	3	4	5	6		

Copyright FCI
 FCIconnect.com

PRODUCT NUMBER
SEE TABLE

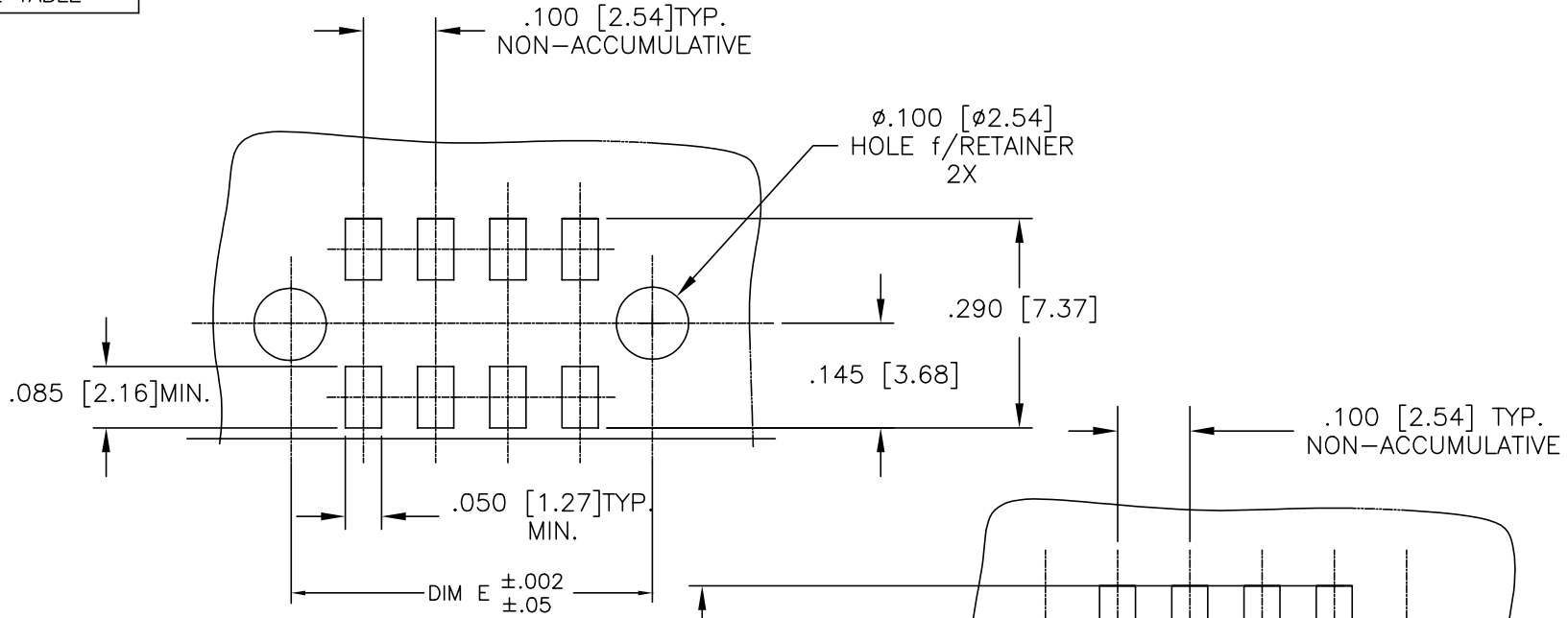

FIGURE A
TOP ENTRY
.025/.64 SQUARE PIN

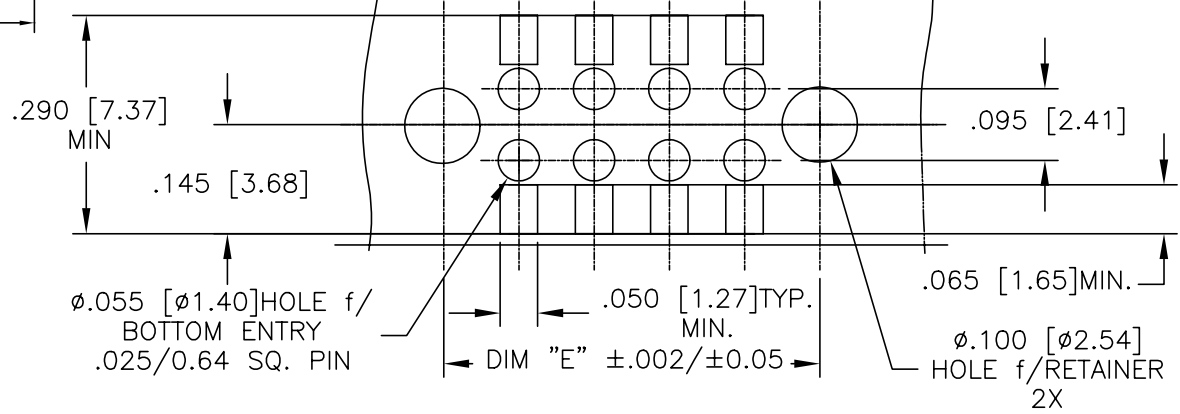

FIGURE B
BOTTOM ENTRY (THROUGH PWB)
.025/.64 SQUARE PIN

mat'l. code		surface ISO 1302 ✓		tolerance ISO 406 ISO 1101		projection ASME Y14.5		product family DUBOX	
ltr ecn nqdr date		tolerances unless otherwise specified		INCH/MM		title SMT DOUBLE ROW VCC ASSEMBLY			
V		angles 0°±2'		linea XX±.01/XX±.3 XXX±.005/XXX±.13 XXXX±.0020/XXXX±.051		scale 1:1		dwg no 69154	
		dr J. SHREINER 12/31/90		engr M. HAHN 12/31/90		chr M. HAHN 12/31/90		sheet 2 of 6 size A3	
		appd M. HAHN 12/31/90						type Product Customer Drawing	
sheet index		revision sheet							

1

2 3

4

5

6

PRODUCT NO.
SEE TABLE

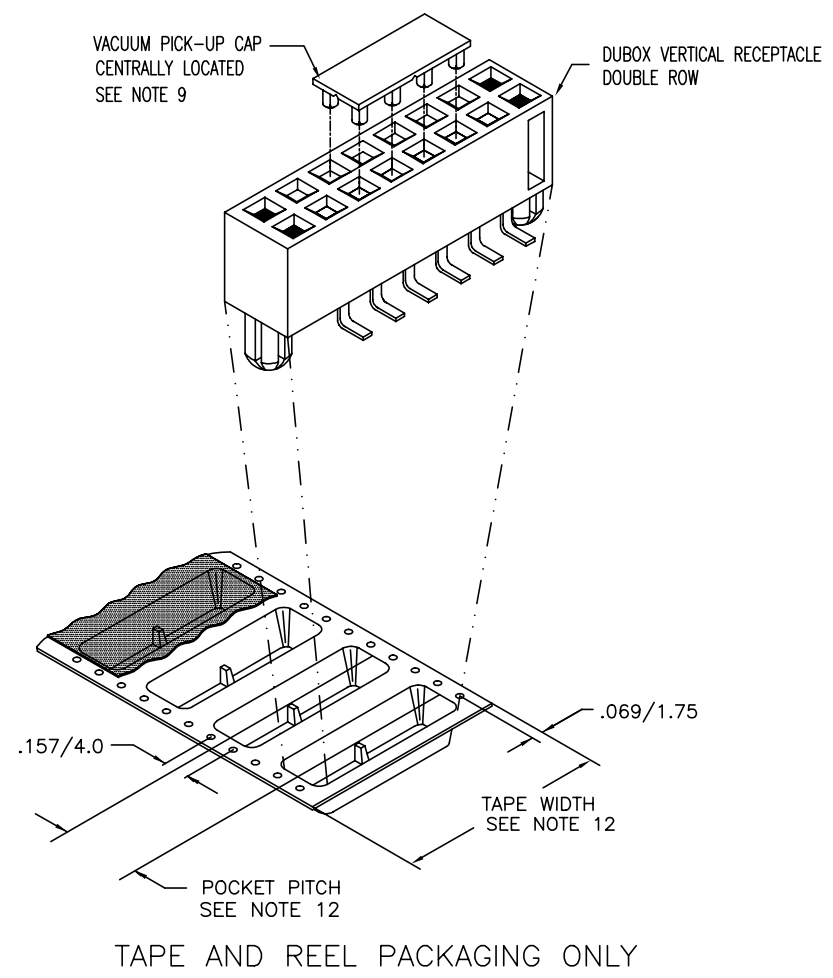

TAPE AND REEL PACKAGING ONLY

mat'l. code		surface	tolerance	projection	product family
ISD 1302		ISD 406	ISD 1101		DUBOX
date		tolerances unless otherwise specified		title	
V		.XX±.01/.X±.3		SMT DOUBLE ROW	
angles		.XXX±.0.005/.XX±.13		VCC ASSEMBLY	
0°±2'		.XXX±.0020/.XXX±.051		scale 1:1	
dr		J. SHREINER	12/31/90	FCJ	
engr		M. HAHN	12/31/90	dwg no 69154	
chr		M. HAHN	12/31/90	sheet 3 of 6	
appd		M. HAHN	12/31/90	size A3	
type		Product Customer Drawing			
sheet index	revision sheet				

FCI
FCIconnect.com

Copyright FCI

PRODUCT NO NOTE 13	PLATING CONTACT AREA	PLATING SOLDER TAIL	MATERIAL REF
69154-2XX	15u"/.38u Au MIN OVER 50u"/1.27u Ni MIN SEE NOTE 16	100u"/160u" SN 2.54u/4.06u	NOTE 3 & 4
69154-3XX	30u"/.76u Au MIN OVER 50u"/1.27u Ni MIN SEE NOTE 16	100u"/160u" SN 2.54u/4.06u	NOTE 3 & 4
69154-6XX	30u"/.76u Au MIN OVER 50u"/1.27u Ni MIN SEE NOTE 16	100u"/160u" SN 2.54u/4.06u	NOTE 3 & 4
69154-8XX	30u"/.76u Au MIN OVER 50u"/1.27u Ni MIN	100u"/160u" SN 2.54u/4.06u	NOTE 3 & 4

— OBSOLETE

NOTES:

- ① MATERIAL TERMINAL: PHOSPHOR BRONZE,
- 2. RECOMMENDED APPLICATION DATA:
 - A. RECOMMENDED SOLDER PAD PATTERN IS SHOWN IN FIGURE A & B.
 - B. ALL MATING PINS TO BE .025/.64. SQUARE ON TRUE CENTER OF GIVEN TERMINAL SPACING WITHIN .015/.38. DIA.
 - C. SUGGESTED MATING PIN LENGTH .210 ±.020/5.33 ±.51.
- ③ MATERIAL HOUSING: P.P.S. FILLED,COLOR BLACK
FLAME RETARDANT PER UL 94V-0.
COMPATIBLE WITH INFRA-RED SOLDERING.
THIS PART WILL WITHSTAND EXPOSURES TO 260°C
PEAK TEMPERATURE FOR 20 SECONDS IN WAVE SOLDER,
INFRA-RED OR VAPOR PHASE SOLDER PROCESS.
- ④ PRESTAMPED POST PLATED TERMINALS.
- 5. FCI, FCI FINAL PART NUMBER AND DATE CODE TO BE MARKED ON TUBE LABEL.
- 6. STANDARD PACKAGING PER BUS-14-097.
- 7. TAPE AND REEL PACKAGING PER GES-14-334.
- 8. CARRIER TAPE WIDTH 24 MIN. & BELOW TO HAVE PILOT HOLES ON ONE SIDE OF TAPE ONLY.
SIZES ABOVE 24mm TO HAVE PILOT HOLES ON BOTH SIDES OF TAPE.
- ⑨ VACUUM CAP MATERIAL FOR TAPE & REEL PACKAGING:
L.C.P., FLAME RETARDANT PER UL 94V-0.
COLOR: BLACK
- ⑩ ADD SUFFIX "P" TO PART DASH NUMBER FOR TAPE AND REEL PACKAGING.
EXAMPLE: 69154-XXXP
- 11. MAXIMUM LENGTH OF CONNECTOR FOR TAPE AND REEL PACKAGING IS 2.50 INCHES LONG/63.5 MM.
- ⑫ TAPE & REEL PACKAGING 72mm WIDE TAPE WITH 16mm POCKET PITCH.
- ⑬ ADD LF SUFFIX AT THE END OF PART NUMBER FOR LEAD FREE OPTION.
- 14. THESE PRODUCTS MEETS EUROPEAN UNION DIRECTIVES AND OTHER COUNTRY REGULATION AS DESCRIBED IN GS-22-008.
- ⑮ "THIS PRODUCT HAS 100% TIN PLATING IN THE INTERFACE AND HAS NOT BEEN TESTED FOR WHISKER GROWTH IN ALL INTERCONNECT ENVIRONMENTS."
- ⑯ PLATING OPTIONS:
MAY BE EITHER GOLD OR GXT PLATED AT MANUFACTURER'S OPTION.



Copyright FCI

mat'l. code		surface <input checked="" type="checkbox"/> ISD 1302 <input checked="" type="checkbox"/> ISD 406 <input type="checkbox"/> ISD 1101		projection	product family DUBOX
l/tecn nodr date		tolerances unless otherwise specified		INCH/MM	title SMT DOUBLE ROW VCC ASSEMBLY
v		angles	linea		
		0°±2°	0.005/0.013	scale 1:1	
		dr J. SHREINER	12/31/90		dwg no
		engr M. HAHN	12/31/90		69154
		chr M. HAHN	12/31/90		sheet 4 of 6
		appd M. HAHN	12/31/90		size A3
sheet index	revision sheet				type Product Customer Drawing

PRODUCT NO	NO OF POS	DIM C	DIM D	DIM E	TAPE & REEL PACKAGING	LF OPTION
69154-Y02	2 X 2	.100/2.54	.417/10.59	.300/7.62	NO	NOTE 13
69154-Y03	2 X 3	.200/5.08	.517/13.13	.400/10.16	NO	
69154-Y04	2 X 4	.300/7.62	.617/15.67	.500/12.70	NO	
69154-Y05	2 X 5	.400/10.16	.717/18.21	.600/15.24	NO	
69154-Y06	2 X 6	.500/12.70	.817/20.75	.700/17.78	NO	
69154-Y07	2 X 7	.600/15.24	.917/23.29	.800/20.32	NO	
69154-Y08	2 X 8	.700/17.78	1.017/25.83	.900/22.86	NO	
69154-Y09	2 X 9	.800/20.32	1.117/28.37	1.000/25.40	NO	
69154-Y10	2 X 10	.900/22.86	1.217/30.91	1.100/27.94	NO	
69154-Y11	2 X 11	1.000/25.40	1.317/33.45	1.200/30.48	NO	
69154-Y12	2 X 12	1.100/27.94	1.417/35.99	1.300/33.02	NO	
69154-Y13	2 X 13	1.200/30.48	1.517/38.53	1.400/35.56	NO	
69154-Y14	2 X 14	1.300/33.02	1.617/41.07	1.500/38.10	NO	
69154-Y15	2 X 15	1.400/35.56	1.717/43.61	1.600/40.64	NO	
69154-Y16	2 X 16	1.500/38.10	1.817/46.15	1.700/43.18	NO	
69154-Y17	2 X 17	1.600/40.64	1.917/48.69	1.800/45.72	NO	
69154-Y18	2 X 18	1.700/43.18	2.017/51.23	1.900/48.26	NO	
69154-Y19	2 X 19	1.800/45.72	2.117/53.77	2.000/50.80	NO	
69154-Y20	2 X 20	1.900/48.26	2.217/56.31	2.100/53.34	NO	
69154-Y21	2 X 21	2.000/50.80	2.317/58.85	2.200/55.08	NO	
69154-Y22	2 X 22	2.100/53.34	2.417/61.39	2.300/58.42	NO	
69154-Y23	2 X 23	2.200/55.88	2.517/63.93	2.400/60.96	NO	
69154-Y24	2 X 24	2.300/58.42	2.617/66.47	2.500/63.50	NO	
69154-Y25	2 X 25	2.400/60.96	2.717/69.01	2.000/66.04	NO	

NOTE 13

mat'l. code		surface ISO 1302 ✓	tolerance ISO 406 ISO 1101	projection 	product family DUBOX	
ltr	ecnr	ndr	date	tolerances unless otherwise specified	title	
U				angles linea 0°±2'	SMT DOUBLE ROW VCC ASSEMBLY	
				.XX±.01/.XX±.3 .XXX±.0.005/.XXX±.13 .XXX±.0020/.XXX±.051	INCH/MM	
				dr J. SHREINER 12/31/90	scale 1:1	
				enr M. HAHN 12/31/90		
				chr M. HAHN 12/31/90		dwg no 69154 sheet 5 of 6 size A3
				appd M. HAHN 12/31/90		type Product Customer Drawing
sheet index	revision sheet					



Copyright FCI

PRODUCT NO	NO OF POS	DIM C	DIM D	DIM E	TAPE & REEL PACKAGING	LF OPTION
69154-Y26	2 X 26	2.500/63.50	2.817/71.55	2.700/68.58	NO	NOTE 13
69154-Y27	2 X 27	2.600/66.04	2.917/74.09	2.800/71.12	NO	
69154-Y28	2 X 28	2.700/68.58	3.017/76.63	2.900/73.66	NO	
69154-Y29	2 X 29	2.800/71.12	3.117/79.17	3.000/76.20	NO	
69154-Y30	2 X 30	2.900/73.66	3.217/81.71	3.100/78.74	NO	
69154-Y31	2 X 31	3.000/76.20	3.317/84.25	3.200/81.28	NO	
69154-Y32	2 X 32	3.100/78.74	3.417/86.79	3.300/83.32	NO	
69154-Y33	2 X 33	3.200/81.28	3.517/89.33	3.400/86.36	NO	
69154-Y34	2 X 34	3.300/83.32	3.617/91.87	3.500/88.90	NO	
69154-Y35	2 X 35	3.400/86.36	3.717/94.41	3.600/91.44	NO	
69154-Y36	2 X 36	3.500/88.90	3.817/96.95	3.700/93.98	NO	
69154-Y37	2 X 37	3.600/91.44	3.917/99.49	3.800/96.52	NO	
69154-Y38	2 X 38	3.700/93.98	4.017/102.03	3.900/99.06	NO	
69154-Y39	2 X 39	3.800/96.52	4.117/104.57	4.000/101.60	NO	
69154-Y40	2 X 40	3.900/99.06	4.217/107.11	4.100/104.14	NO	
69154-Y41	2 X 41	4.000/101.60	4.317/109.65	4.200/106.68	NO	
69154-Y42	2 X 42	4.100/104.14	4.417/112.19	4.300/109.22	NO	
69154-Y43	2 X 43	4.200/106.68	4.517/114.73	4.400/111.76	NO	
69154-Y44	2 X 44	4.300/109.22	4.617/117.27	4.500/114.30	NO	
69154-Y45	2 X 45	4.400/111.76	4.717/119.81	4.600/116.84	NO	
69154-Y46	2 X 46	4.500/114.30	4.817/122.35	4.700/119.38	NO	
69154-Y47	2 X 47	4.600/116.84	4.917/124.89	4.800/121.92	NO	
69154-Y48	2 X 48	4.700/119.38	5.017/127.43	4.900/124.46	NO	
69154-Y49	2 X 49	4.800/121.92	5.117/129.97	5.000/127.00	NO	
69154-Y50	2 X 50	4.900/124.46	5.217/132.51	5.100/129.54	NO	
69154-Y16P	2 X 16	1.500/38.10	1.817/46.15	1.700/43.18	YES - NOTE 10 & 12	

NOTE 13

mat'l. code		surface ISO 1302	tolerance ISO 406 ISO 1101	projection 	product family DUBOX
ltr	ecnr	ndr	date	tolerances unless otherwise specified	title SMT DOUBLE ROW VCC ASSEMBLY
V				angles linea 0°±2'	INCH/MM scale 1:1
				dr J. SHREINER 12/31/90	dwg no 69154 sheet 6 of 6 size A3
				enrg M. HAHN 12/31/90	
				chr M. HAHN 12/31/90	
				appd M. HAHN 12/31/90	type Product Customer Drawing
sheet index	revision sheet				