



Chipsmall Limited consists of a professional team with an average of over 10 year of expertise in the distribution of electronic components. Based in Hongkong, we have already established firm and mutual-benefit business relationships with customers from,Europe,America and south Asia,supplying obsolete and hard-to-find components to meet their specific needs.

With the principle of "Quality Parts,Customers Priority,Honest Operation,and Considerate Service",our business mainly focus on the distribution of electronic components. Line cards we deal with include Microchip,ALPS,ROHM,Xilinx,Pulse,ON,Everlight and Freescale. Main products comprise IC,Modules,Potentiometer,IC Socket,Relay,Connector.Our parts cover such applications as commercial,industrial, and automotives areas.

We are looking forward to setting up business relationship with you and hope to provide you with the best service and solution. Let us make a better world for our industry!



## Contact us

Tel: +86-755-8981 8866 Fax: +86-755-8427 6832

Email & Skype: info@chipsmall.com Web: www.chipsmall.com

Address: A1208, Overseas Decoration Building, #122 Zhenhua RD., Futian, Shenzhen, China



**PROPER USE GUIDELINES**

Cumulative Trauma Disorders can result from the prolonged use of manually powered hand tools. Hand tools are intended for occasional use and low volume applications. A wide selection of powered application equipment for extended-use, production operations is available.

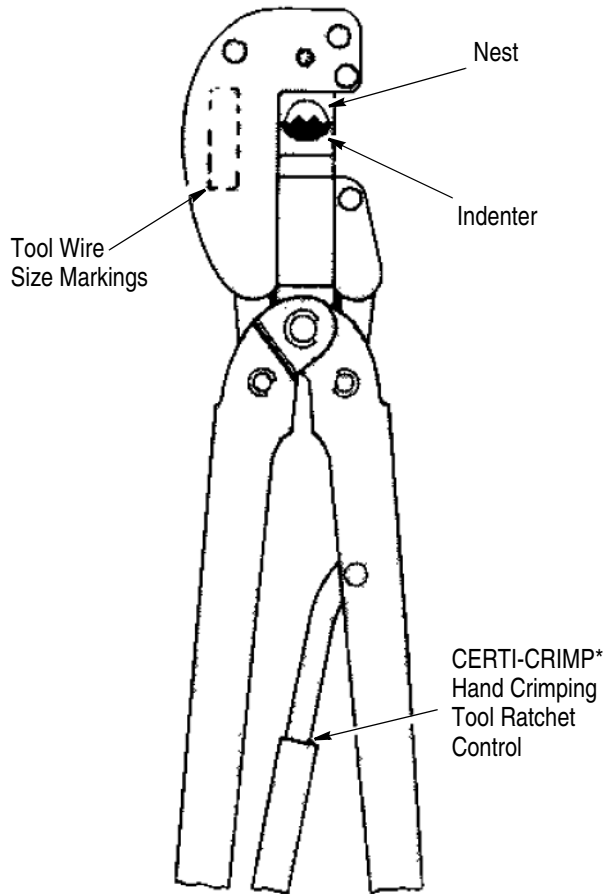

Figure 1

**1. INTRODUCTION**

This instruction sheet provides information for product application and maintenance and inspection procedures for Terminal and Splice Crimping Tools 69339, 69354-1, and 69355.

These tools are used to crimp:

- SOLISTRAND\* Terminals, butt and parallel splices on solid or stranded copper wire sizes 6 and 8 AWG
- SOLISTRAND Flag Terminals on solid or stranded copper wire size 8 AWG
- STRATO-THERM\* heat resistant uninsulated terminals on solid or stranded copper wire size 8 AWG

Basic instructions on the use of this tool, wire preparation, tool adjustments, etc. are provided in Section 2, INSTRUCTIONS. Section 3 features a terminal CRIMP INSPECTION procedure. Section 4 contains a MAINTENANCE and INSPECTION PROCEDURE.

Tools are coated with preservative to prevent rust and corrosion. Wipe this preservative from the tool, particularly from the crimping area.

**NOTE** *Dimensions are in millimeters [with inch equivalents in brackets]. Figures and illustrations are for identification only and are not drawn to scale.*

Read these instructions carefully before using the tool.

Reasons for reissue of this sheet are provided in Section 5, REVISION SUMMARY.

**2. INSTRUCTIONS FOR WIRE STRIPPING AND CRIMPING PROCEDURES**

1. Strip wires to the dimensions listed in Figure 2.

**CAUTION** *Do NOT use wire with nicked or missing strands.*

2. Open crimping dies by closing handles until CERTI-CRIMP hand crimping tool ratchet control releases. See Figure 1. Note that once the ratchet is engaged, handles cannot be opened again until they are fully closed.

**NOTE** *Be sure wire size displayed on tool head and in stationary die nest matches wire size stamped on the terminal or splice.*

Determine correct terminal or splice wire loading by referring to the CMA range listed in Figure 2.

**Terminals**

3. Center wire barrel of terminal in nest of stationary die as shown in Figure 3A.
4. Center wire barrel of flag terminal in dies being sure that “tongue” portion of wire barrel is against indenter of moving die as shown in Figure 3B.

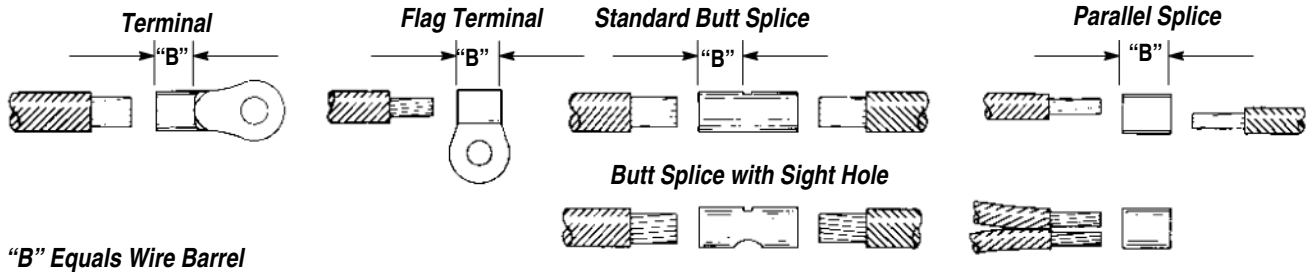

| TOOL NUMBER | WIRE SIZE | CIRCULAR MILL AREA RANGE | WIRE STRIP LENGTH (mm [in.]) |                |                |                 |                 |                 |                 |                 |
|-------------|-----------|--------------------------|------------------------------|----------------|----------------|-----------------|-----------------|-----------------|-----------------|-----------------|
|             |           |                          | TERMINAL                     |                | FLAG TERMINAL  |                 | BUTT SPLICE     |                 | PARALLEL SPLICE |                 |
|             |           |                          | Min.                         | Max.           | Min.           | Max.            | Min.            | Max.            | Min.            | Max.            |
| 69339●      | 8         | 13,100-20,800            | 8.33<br>[.328]               | 9.12<br>[.359] | ---            | ---             | 10.31<br>[.406] | 11.13<br>[.438] | 10.31<br>[.406] | 11.13<br>[.438] |
| 69354-1●●   | 8         |                          | ---                          | ---            | 9.52<br>[.375] | 11.13<br>[.438] | ---             | ---             | ---             | ---             |
| 69355●●●    | 8         |                          | 8.33<br>[.328]               | 9.12<br>[.359] | ---            | ---             | 10.31<br>[.406] | 11.13<br>[.438] | 10.31<br>[.406] | 11.13<br>[.438] |

●Stranded wire only. ●●Flag terminals only. ●●●Also used for STRATO-THERM Heat Resistant Terminals.

Figure 2

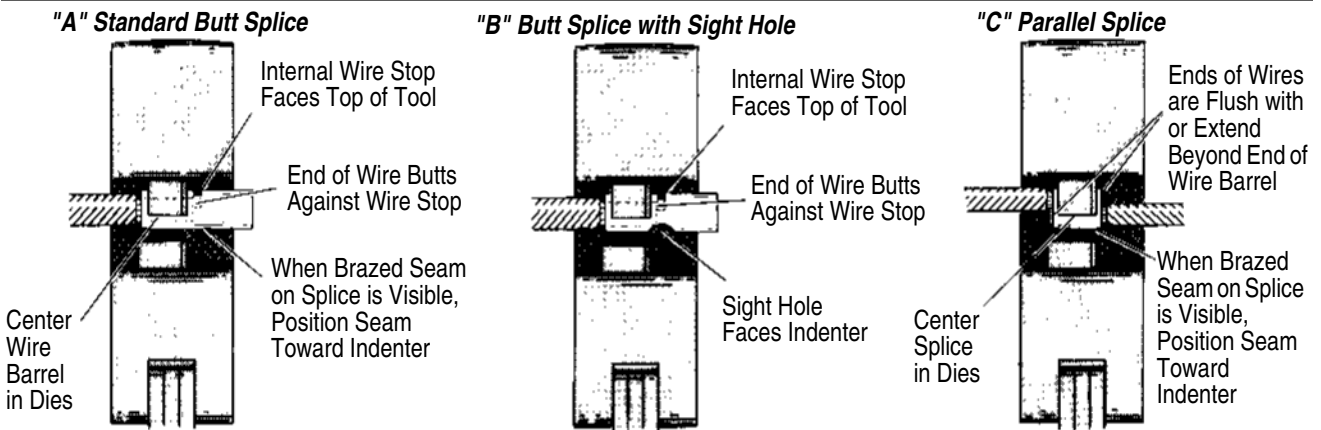
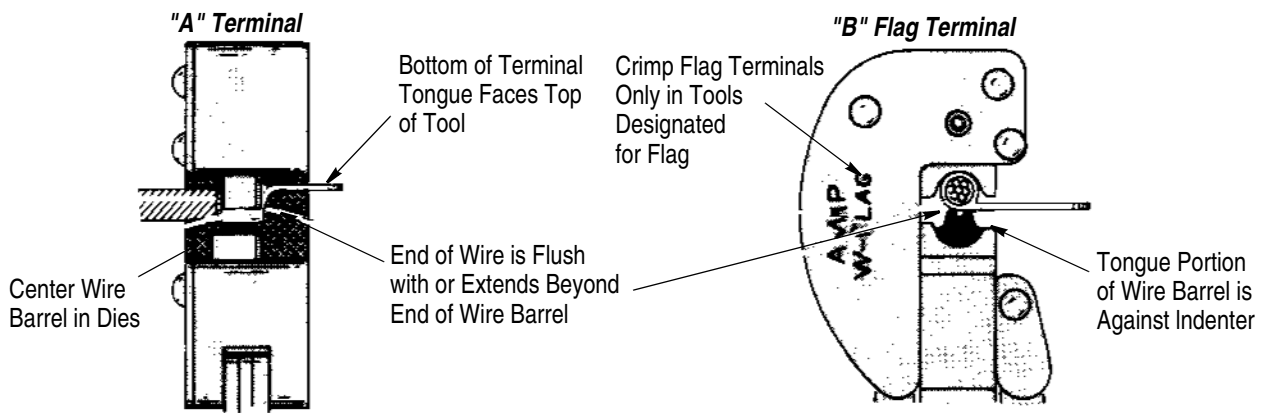

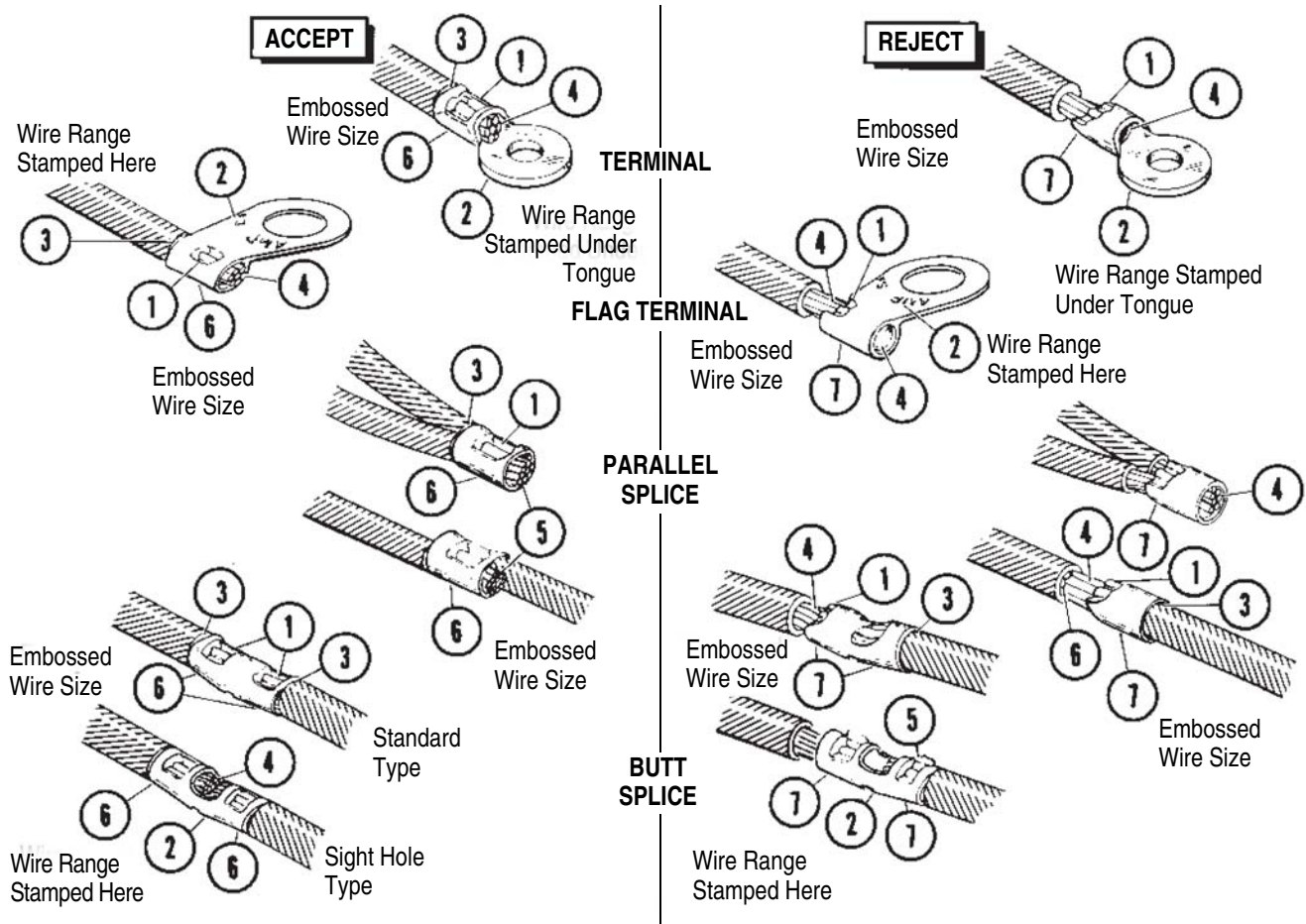

- 1 Crimps centered. Crimps may be off center BUT NOT OFF END OF WIRE BARREL.
- 2 AWG wire size being used matches wire size stamped on terminal or splice and head of crimping tool.
- 3 Insulation does not enter wire barrel.
- 4 Wire is visible through inspection hole of butt splices. Wire is flush with or extends slightly beyond end of terminal wire barrel.
- 5 On parallel splices, bare wire ends must be flush with or extend slightly beyond end of barrel.
- 6 Wire size embossed on crimped wire barrel matches wire size stamped on terminal or splice.

- 1 Crimped off end of splice or terminal wire barrel.
- 2 AWG wire size being used does not match wire size stamped on terminal or splice and head of crimping tool.
- 3 Insulation entered barrel of terminal or splice. CHECK FOR INCORRECT STRIP LENGTH.
- 4 Wire not inserted far enough in terminal of splice. End of wire must be visible through inspection hole of butt splices, and be flush with or extend slightly beyond end of terminal wire barrel or parallel splice.
- 5 Excessive "flash" on terminal or splice indicates wrong wire, terminal or splice, or tooling combination was used.
- 6 Nicked or missing strands.
- 7 Wire size embossed on crimped wire barrel does not match wire size stamped on terminal or splice.

Figure 5

5. Close handles until terminal is held firmly in place. Do NOT deform terminal wire barrel.
6. Insert stripped wire into terminal until end of wire is at least flush with or extended slightly beyond end of wire barrel. See Figures 3A or 3B.
7. To complete the crimp, close the handles until the CERTI-CRIMP hand crimping tool ratchet control releases. Handles can now be opened and the crimped terminal may be removed.
8. Refer to Section 3 and Figure 5 for terminal crimp inspection procedures.

### Splices

9. Center one half of the butt splice in nest as shown in Figure 4A or 4B. For best results, when brazed seam on splice is visible, position the seam toward the indenter.
10. Center parallel splice in nest as shown in Figure 4C. Be sure brazed seam faces indenter.
11. Close handles until splice is held firmly in place. Do NOT deform splice wire barrel.
12. Insert stripped wire into butt splices until end of wire butts against wire stop in splice as shown in Figure 4A or 4B. Insert stripped wire into parallel

splices until end of wire is flush with or extended slightly beyond end of wire barrel as shown in Figure 4C.

13. To complete crimp, close the handles until the CERTI-CRIMP hand crimping tool ratchet control releases. Handles can now be opened and the crimped splice may be removed.

14. To crimp the other half of the butt splice, remove it and re-position uncrimped half in nest. Follow the same procedure used to crimp the first half of the splice.

15. Refer to Section 3 and Figure 5 for splice crimp inspection procedures.

### 3. CRIMP INSPECTION

Inspect crimped terminals and splices by checking the features described in Figure 5. Use only the terminals and splices that meet the conditions shown in the "ACCEPT" column. "REJECT" terminals and splices can be avoided through careful use of instructions in Section 2 and by performing regular tool maintenance as instructed in Section 4.

### 4. MAINTENANCE/INSPECTION PROCEDURE

TE Connectivity recommends that a maintenance/inspection program be performed periodically to ensure dependable and uniform terminations. Tools should be inspected at least once a month. Frequency of inspection may be adjusted to suit your requirements through experience. Frequency of inspection is dependent upon:

- The care, amount of use, and handling of the tool
- The type and size of the products crimped
- The degree of operator skill
- The presence of abnormal amounts of dust and dirt
- Your own established standards

All tools are inspected and calibrated before packaging. Since there is a possibility of tool damage in shipment, new tools should be inspected in accordance with Section 4 when received in your plant. Due to the precision design, *it is important that no parts of these tools be interchanged except those replacement parts listed in Figure 9.*

#### 4.1. Cleaning

The tool should be immersed (handles partially closed) in degreasing compound to remove accumulated dirt, grease, and foreign matter. Remove remaining degreasing compound with a lint free cloth. When degreasing compounds are not available, tool may be wiped clean with a lint-free cloth. Relubricate tool, as instructed in Paragraph 4.3, before placing it back in service.

### 4.2. Visual Inspection

1. Inspect the tool for missing pins or retaining rings. If parts are missing or defective, refer to Figure 9 for customer replaceable parts.
2. Inspect the die closure surfaces for flattened, broken, or chipped conditions. Although dies may gage within permissible limits, worn or damaged die closure surfaces are objectionable and can affect the quality of the crimp. Examples of possible damaged die closure surfaces are shown in Figure 6.

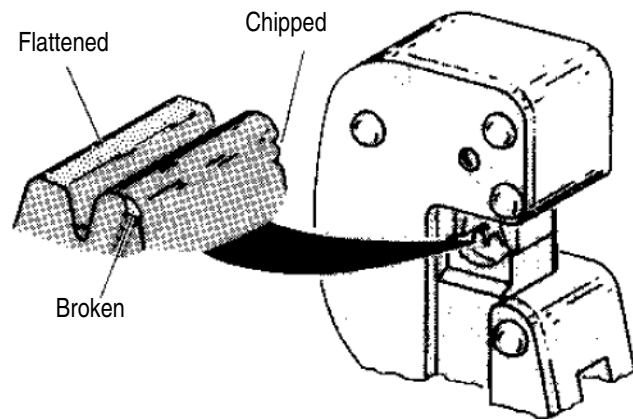

Figure 6

### 4.3. Lubrication

Lubricate all pins, pivot points, and bearing surfaces with a good grade S.A.E. No. 20 motor oil as follows:

- Tools used in daily production - Lubricate daily
- Tools used daily (occasional) - Lubricate weekly
- Tools used weekly - Lubricate monthly

Wipe excess oil from tool, particularly from crimping area. Oil transferred from the crimping area onto certain terminations may affect the electrical characteristics of an application.

### 4.4. Die Closure Inspection

Each tool is inspected for proper die closure before packaging. An inspection should be performed periodically to check the tool die closure for excessive wear.

The die closure inspection is accomplished using a GO/NO-GO plug gage. TE neither manufactures nor sells plug gages. Suggested design and GO/NO-GO dimensions for the plug gage members are listed in Figure 7. The following procedure is recommended for inspecting the die closure.

**SUGGESTED PLUG GAGE DESIGN - WIRE BARREL CRIMP**

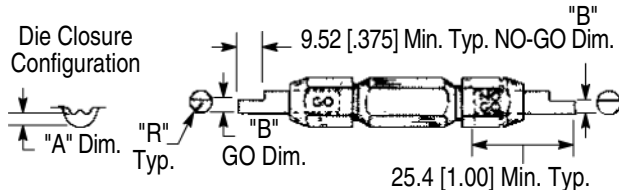

| TOOL    | DIE CLOSURE DIM's "A"† |                  | GAGE MEMBER‡ DIM's "B"       |                              | RADIUS "R"     |
|---------|------------------------|------------------|------------------------------|------------------------------|----------------|
|         | GO                     | NO-GO            | GO                           | NO-GO                        |                |
| 69339   | 3.200<br>[.1260]       | 3.353<br>[.1320] | 3.200-3.208<br>[.1260-.1263] | 3.350-3.353<br>[.1319-.1320] | 3.51<br>[.138] |
| 69354-1 | 2.540<br>[.1000]       | 2.692<br>[.1060] | 2.540-2.548<br>[.1000-.1003] | 2.690-2.692<br>[.1059-.1060] | 3.18<br>[.125] |
| 69355   | 2.540<br>[.1000]       | 2.692<br>[.1060] | 2.540-2.548<br>[.1000-.1003] | 2.690-2.692<br>[.1059-.1060] | 3.18<br>[.125] |

†Die closure dimensions apply when dies are bottomed but not under pressure. ‡Material-Tool Steel

Figure 7

1. Clean oil or dirt from the die closure and plug gage members.
2. Close handles of tool until dies are bottomed. Do NOT apply additional pressure to tool handles. see Figure 8A.
3. With dies bottomed, inspect the die closure using the proper plug gage.
4. Hold gage in straight alignment with the die closure and carefully try to insert, without forcing, the GO member. See Figure 8, Detail A. The GO member must pass completely through the die closure.
5. Try to insert the NO-GO member. The NO-GO member may enter partially, but must not pass completely through the die closure.

**INSPECTION OF WIRE BARREL CRIMPING DIES**

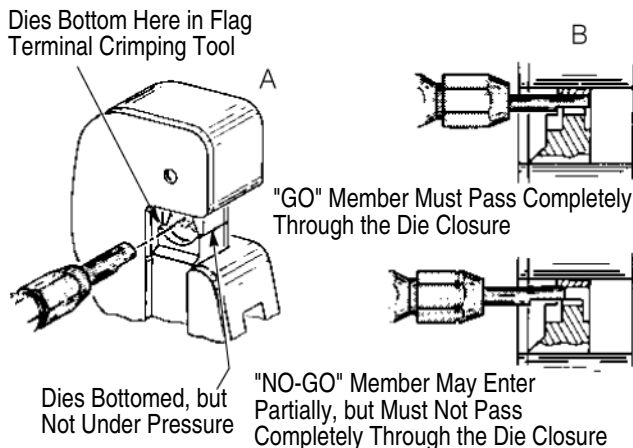

Figure 8

6. If the die closure meets the GO/NO-GO gage conditions, the die closure may be considered dimensionally correct.
7. If you find that the die closure does not conform with the GO/NO-GO gage conditions, contact your local TE Representative.

**4.5. CERTI-CRIMP Hand Crimping Tool Ratchet Control Inspection**

The CERTI-CRIMP hand crimping tool ratchet control feature on hand tools should be checked to make certain that the ratchet does not release prematurely allowing dies to open before they have fully bottomed. To check the ratchet feature:

1. Thoroughly clean the bottoming surfaces of the dies.
2. Make a test crimp using a properly stripped No. 8 AWG wire and a terminal. When this crimp is made, squeeze handles until the ratchet is free, however, DO NOT RELAX PRESSURE ON TOOL HANDLES.
3. Bottoming is satisfactory if bottoming surfaces of the wire barrel crimp dies make contact with each other or if the clearance between the bottoming surfaces is 0.03 mm [.001 in.] or less.
4. If the 0.03 mm [.001 in.] shim stock can be inserted completely between the bottoming surfaces of the wire barrel crimp dies, the dies are considered as not bottoming. Contact your local TE Representative.

**4.6. Replacement Parts**

The parts listed in Figure 9 are customer- replaceable. A complete inventory can be stocked and controlled to prevent lost time when replacement of parts is necessary. Order replacement parts through your TE Representative, or call 1-800-526-5142, or send a facsimile of your purchase order to 717-986-7605, or write to:

CUSTOMER SERVICE (038-035)  
 TYCO ELECTRONICS CORPORATION  
 PO BOX 3608  
 HARRISBURG PA 17105-3608

Tools may be returned to TE for evaluation and repair. For tool repair service, contact a TE Representative at 1-800-526-5136.

**5. REVISION SUMMARY**

- Updated document to corporate requirements
- Changed information in Figure 9

**NOTE:** Approximately 307.98 mm [12.125 in.]  
Long, Assembled, and Handles Closed

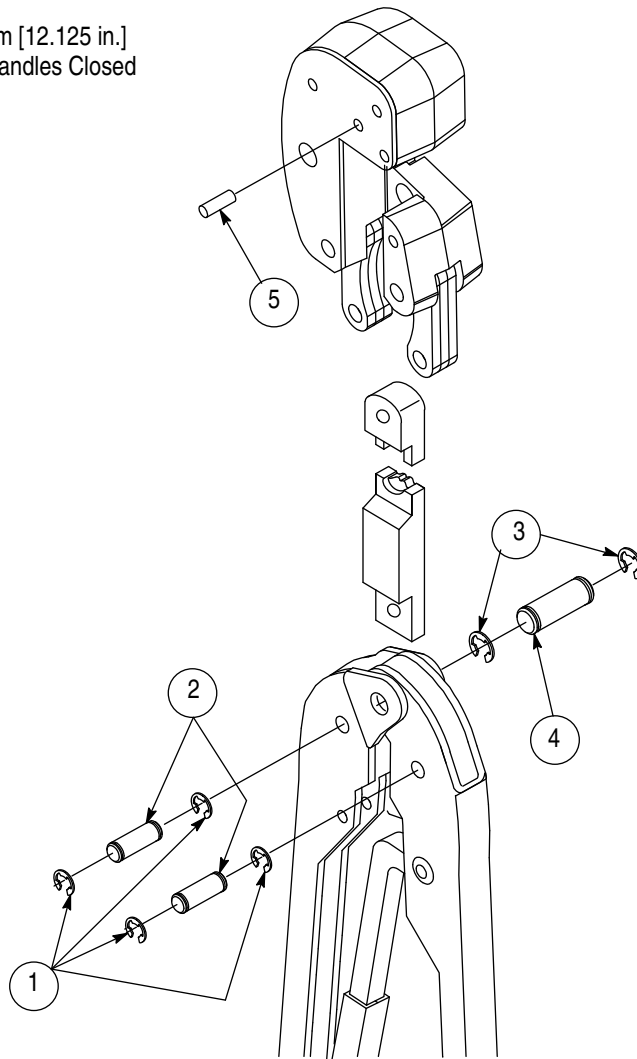

| ITEM No. | DESCRIPTION     | QTY PER TOOL | HAND TOOLS |           |           |
|----------|-----------------|--------------|------------|-----------|-----------|
|          |                 |              | 69339      | 69354-1   | 69355     |
| 1        | RING, Retaining | 4            | 21045-3    | 21045-3   | 21045-3   |
| 2        | PIN             | 2            | 300388     | 300388    | 300388    |
| 3        | RING, Retaining | 2            | 21045-6    | 21045-6   | 21045-6   |
| 4        | PIN             | 1            | 300389     | 300389    | 300389    |
| 5        | PIN             | 1            | 5-21028-7  | 5-21028-7 | 5-21028-7 |

Figure 9