



Chipsmall Limited consists of a professional team with an average of over 10 year of expertise in the distribution of electronic components. Based in Hongkong, we have already established firm and mutual-benefit business relationships with customers from,Europe,America and south Asia,supplying obsolete and hard-to-find components to meet their specific needs.

With the principle of “Quality Parts,Customers Priority,Honest Operation,and Considerate Service”,our business mainly focus on the distribution of electronic components. Line cards we deal with include Microchip,ALPS,ROHM,Xilinx,Pulse,ON,Everlight and Freescale. Main products comprise IC,Modules,Potentiometer,IC Socket,Relay,Connector.Our parts cover such applications as commercial,industrial, and automotives areas.

We are looking forward to setting up business relationship with you and hope to provide you with the best service and solution. Let us make a better world for our industry!



Contact us

Tel: +86-755-8981 8866 Fax: +86-755-8427 6832

Email & Skype: info@chipsmall.com Web: www.chipsmall.com

Address: A1208, Overseas Decoration Building, #122 Zhenhua RD., Futian, Shenzhen, China



1. SOLISTRAND* TERMINALS AND SPLICES

SOLISTRAND* Terminals and Splices

(Refer to pages 4 and 5 for application tooling and accessories).

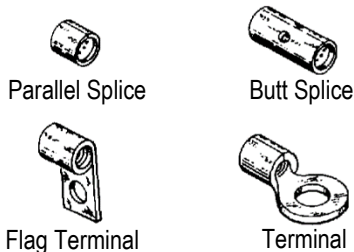

Pressure Type Wire Connector Chart (Use Type "W" Tooling)

WIRE SIZE RANGE	UL 424C LISTED	SP LR 7189 CERTIFIED
22-16 Solid or Stranded	22-16 Solid or Stranded	22-16 Solid or Stranded
16-14 Solid or Stranded	16-14 Solid or Stranded	16-14 Solid or Stranded
12-10 Solid or Stranded	12-10 Stranded	12-10 Solid or Stranded
8 Thru 600 MCM Solid or Stranded	8 Thru 600 MCM Stranded	8 Thru 4/0 Solid or Stranded

NOTE: 22-16 terminals and splices are stamped 22-18 in accordance with MIL-T-7928.

Figure 1

1.1. Tool and Die Selections

A. Hydraulic

Wire Size	Dies for 59973-1, 69065		Dies for 69067		59975-5, 69069 with/Self-Contained Dies	Dies for 48445-1, 1752788-1	Dies for 69082, 1752786-1	Dies for 69097		Dies for 69099, 1752868-1
	Nest	Indenter	Nest	Indenter				Nest	Indenter	
8	48126	48355	48126 [^] 48506 [^]	48355 [^] 48505 [^]	59975-1 69069	---	---	46146	46145	69216
8 H.D.	48128-1	48127-1	48128-1	48127-1	---	---	---	---	---	---
6	48128	48127	48128 [^] 48508 [^]	48127 [^] 48507 [^]	59975-1 69069	---	---	46134	46133	69217
6 H.D.	48129-1	48127-1	48129-1	48127-1	---	---	---	---	---	---
4	48129	48127	48129 [^] 48509 [^]	48127 [^] 48507 [^]	59975-1 69069	---	---	46135	46133	69218
4 H.D.	48130-1	48127-1	48130-1	48127-1	---	---	---	---	---	---
2	48130	48127	48130 [^] 48510 [^]	48127 [^] 48507 [^]	59975-1 69069	---	---	46136	46133	45433
2 H.D.	48132-1	48131-1	48132-1	48131-1	---	---	---	---	---	---
1/0	48132	48131	48132 [^] 48652 [^]	48131 [^] 48511 [^]	---	---	---	46138	46137	45436
1/0 H.D.	48133-1	48131-1	48133-1	48131-1	---	---	---	---	---	---
2/0	48133	---	48133 [^] 48805 [^]	48131 [^] 48511 [^]	---	---	---	---	---	45439
3/0	48134	48131	48134 [^] 48806 [^]	48131 [^] 48511 [^]	---	---	---	---	---	45442
4/0	300430	---	300430 [^] 48807 [^]	48131 [^] 48511 [^]	---	---	---	---	---	45445
250-300 MCM	---	---	---	---	---	48816	69911	---	---	---
300-350 MCM	---	---	---	---	---	48817	69912	---	---	---
400 MCM	---	---	---	---	---	48818	69913	---	---	---
500-600 MCM	---	---	---	---	---	48819	69914	---	---	---

[^] Flag Terminals

Figure 2

B. Hand Tools

Wire Size	HAND TOOLS
26-22	69363†
22-18	---
22-16	49935†
16-14	49935†
14-12	49592†
12-10 16-14 H.D.	49935†
	49965† (Flag Only)
8	69339● (Str. Wire)
	69355●
6	59083● (No Ratchet)
4	---
2	---
1/0	---

†Long Handle, ●Heavy Head

Figure 3

C. Pneumatic and Tape

Wire Size	PNEUMATIC				TAPE	
	Heads for 626	Heads for 69015	Jaws for 68068-[]	Dies for 69710-1	Dies for 69875 •Reversed ••Standard	Dies for 68250-1
26-22	---	---	---	---	68108-1	---
22-18	314516-1 679301-1	---	---	---	---	---
22-16	314516-1 679301-1	---	---	47812	68240-1• 68096-1••	---
16-14	314517-1 679301-1	---	---	47813	68241-1• 68097-1••	---
14-12	314518-1 679301-1	---	---	---	90566-1	---
12-10 16-14 H.D.	679301-1	---	---	47814†	68242-1• 68338-1••	---
8	1338757-1	49956	68135	---	68243-1◇	68312-1◇
		48412●				
6	1338758-1	48172	68136	---	---	68313-1◇
		48413●				
4	---	48173	---	---	---	---
2	---	48174	---	---	---	---
		48415●				
1/0	---	48183	---	---	---	---

● Flag Terminals, † Str. Wire Only, ◇ Single Indent

Figure 4

2. AMPOWER* TERMINALS AND SPLICES

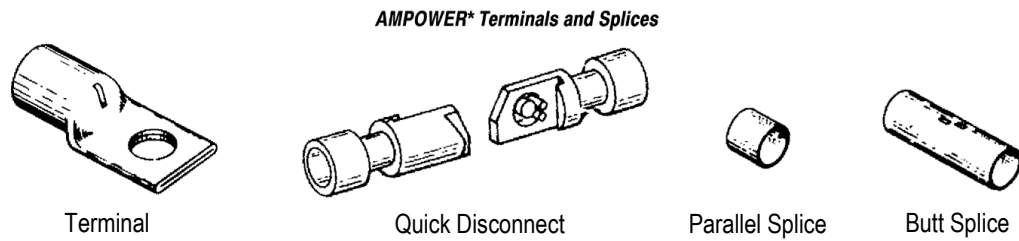

Pressure Type Wire Connector Chart
(Use Type "C" Tooling)

WIRE SIZE RANGE	 424C LISTED	 LR 7189 CERTIFIED
6 thru 1000 MCM	6 thru 1000 MCM Stranded	6 thru 1000 MCM Stranded

Figure 5

2.1. Tool and Die Selections

A. Hydraulic (Use Power Unit 69120-[] or 314979-1)

Wire Size	Dies for 69099 1752868-1	Dies for 69082 1752786-1	Dies for 69065 59973-1	Dies for 58445-1 1752788-1	Dies for 68073-2
6	69133-1	---	---	---	---
4	69134-2	---	---	---	---
2	46765-3	---	46321-3	---	---
1/0	46766-2	---	46322-2	---	---
	68361-1† (with Locator)				
2/0	46767-2	---	46323-2	---	---
	68253-1† (with Locator)				
3/0	46749-2	---	46324-2	---	---
	59867-1† (with Locator)				
4/0	46750-2	---	46325-2	---	---
	68304-1† (with Locator)				
250 MCM	46751-2 68203-1†	---	---	46326-2	---
300 MCM	46752-2	---	---	---	---
350 MCM	46753-2	69653 68204-1†	---	---	---
400 MCM	---	46754-2 68332-1†	---	---	---
500 MCM	---	46755-2 68206-1†	---	---	---
600 MCM	---	46756-2	---	---	---
600 H.D.	---	59870-1	---	---	---
700 MCM	---	46757-2	---	---	---
800 MCM	---	46758-2	---	---	---
900 MCM	---	46759-2	---	---	---
1000 MCM	---	46760-2	---	---	---
1250 MCM	---	---	---	---	68114-1
1500 MCM	---	---	---	---	68282-1

†Quick Disconnect Terminals Only

Figure 6

Tooling and Accessories

Hydraulic

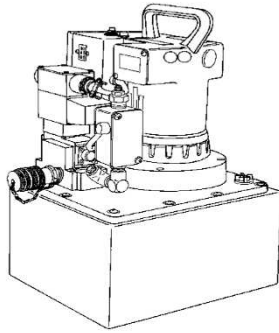

DYNA-CRIMP*
 Hydraulic Power Units
 69120-1 (115 VAC – 60 Hz)
 1804700-1 (115 VAC – 60 Hz)
 69120-2 (230 VAC – 60 Hz)
 1804700-2 (230 VAC – 60 Hz)

Handle Control w/Hose and
 Cord 59907-[] and 1901775-[]



Foot Control
 68284-1

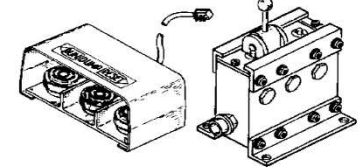

3-Way Multi-
 directional Valve
 59220 (No Safety Sw)
 59220-2 (w/Safety Sw)

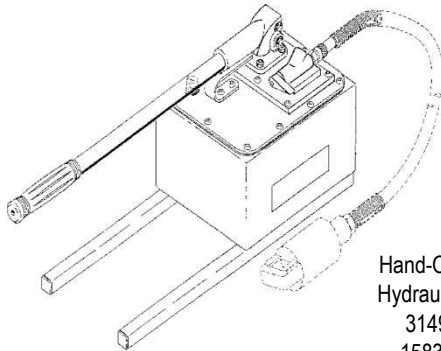

Hand-Operated
 Hydraulic Pump
 314979-1
 1583661-1

Hose Assy w/Crimping
 Head Coupling
 59909-[], 1583662-[]

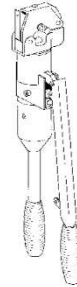

Hand Tool
 59975-1

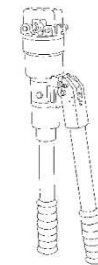

Hand Tool
 59973-1

Tape Machines

AMP-TAPETRONIC*
 Machine 68250-1

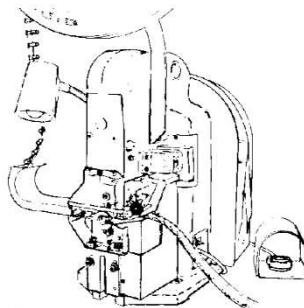

AMP-TAPETRONIC*
 Machine 69875

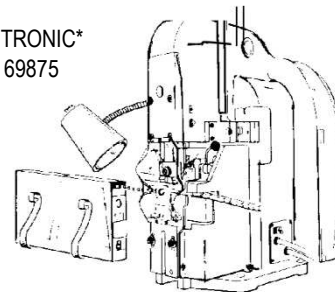

Pneumatic

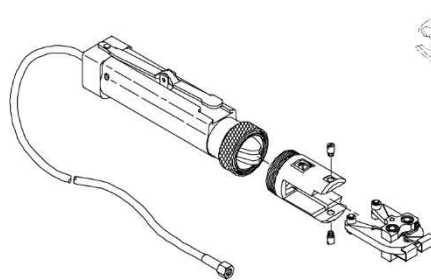

626 Pneumatic Tooling Systems

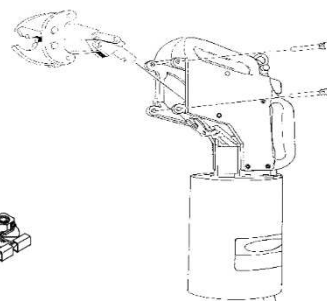

69015

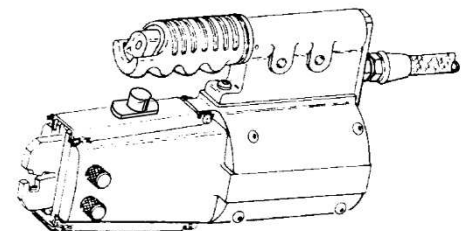

68068

Figure 7

Tooling and Accessories

Hydraulic Crimping Heads

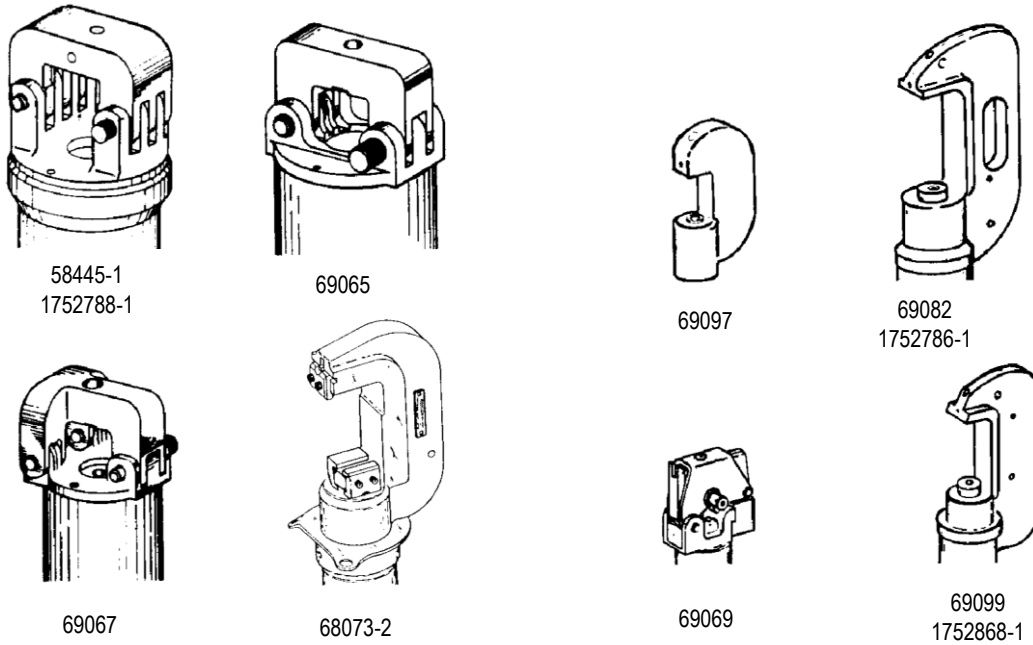

Figure 8

Hand Tools

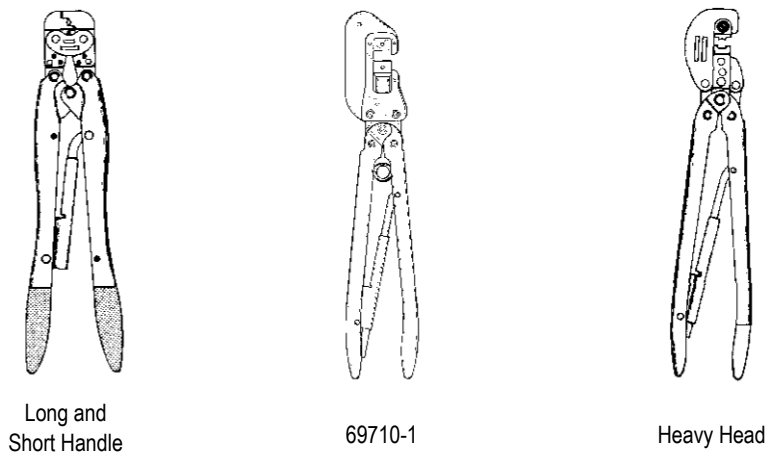

Figure 9

3. REVISION SUMMARY

- ◆ All paragraphs revised due to formatting adjustments and editing.
- ◆ Corrections to Figure 6 were made, as follows: added line item for 350 MCM and corrected line item for 400 MCM to match previous revision.