



Chipsmall Limited consists of a professional team with an average of over 10 year of expertise in the distribution of electronic components. Based in Hongkong, we have already established firm and mutual-benefit business relationships with customers from,Europe,America and south Asia,supplying obsolete and hard-to-find components to meet their specific needs.

With the principle of "Quality Parts,Customers Priority,Honest Operation,and Considerate Service",our business mainly focus on the distribution of electronic components. Line cards we deal with include Microchip,ALPS,ROHM,Xilinx,Pulse,ON,Everlight and Freescale. Main products comprise IC,Modules,Potentiometer,IC Socket,Relay,Connector.Our parts cover such applications as commercial,industrial, and automotives areas.

We are looking forward to setting up business relationship with you and hope to provide you with the best service and solution. Let us make a better world for our industry!



## Contact us

Tel: +86-755-8981 8866 Fax: +86-755-8427 6832

Email & Skype: info@chipsmall.com Web: www.chipsmall.com

Address: A1208, Overseas Decoration Building, #122 Zhenhua RD., Futian, Shenzhen, China





THIS DRAWING IS UNPUBLISHED. RELEASED FOR PUBLICATION  
 © COPYRIGHT BY TYCO ELECTRONICS CORPORATION. ALL RIGHTS RESERVED.

LOC	DIST	REVISIONS					
G	14	P	LTR	DESCRIPTION	DATE	DWN	APVD
		C		REV PER ECR 10-005107	08MAR10	JR	TM

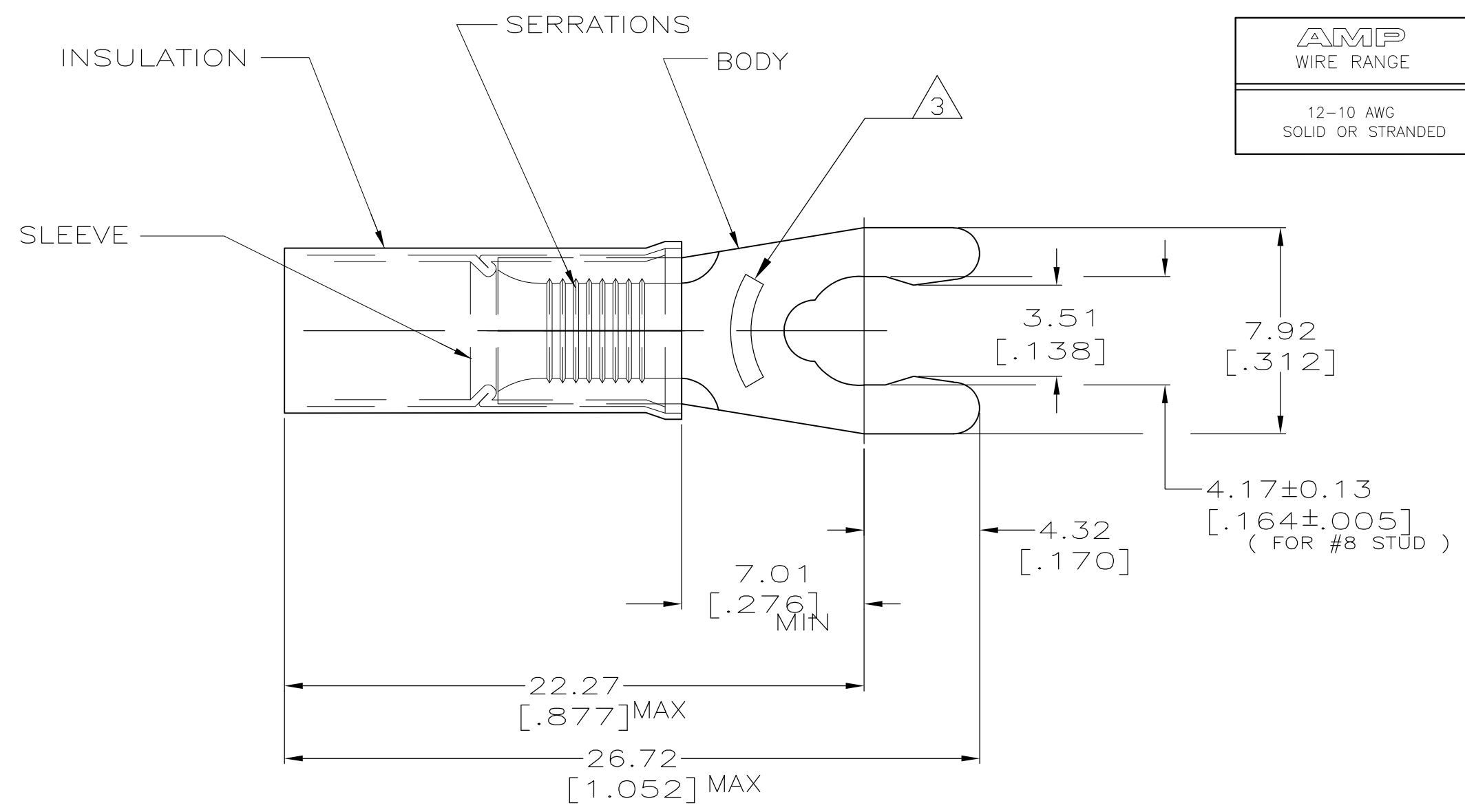
<b>AMP</b> WIRE RANGE	 Listed FILE E13288
12-10 AWG SOLID OR STRANDED	12-10 AWG SOLID OR STRANDED

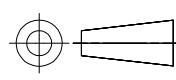

- 1 FOR 3.81-6.35 [.150-.250] WIRE INSULATION DIA.
- 2 TONGUE MATERIAL THK IS 0.98±0.05 [.0385±.002]
-  STAMP " 8S AMP 12-10\* ", LOCATED APPROX AS SHOWN.

2500	696072-1 ON TAPE	696072-2	INSULATION : NYLON, COLOR: YELLOW SLEEVE: COPPER (ASTM B-152)
500	LOOSE PIECE	696072-1	BODY: PHOSPHOR BRONZE PER ASTM B103 TIN PLATE PER ASTM B545
QTY	DESCRIPTION	PART NO.	MATERIAL & FINISH
THIS DRAWING IS A CONTROLLED DOCUMENT.		DWN JR RUTH 12/17/98	 Tyco Electronics Corporation Harrisburg, PA 17105-3608
DIMENSIONS: MM [ INCHES ]		CHK MS FEHER 12/17/98	
		APVD J TALLEY 12/17/98	
TOLERANCES UNLESS OTHERWISE SPECIFIED:		NAME	WIRE TERMINAL, PIDG - SPRING SPADE (STUB) WIRE SIZE : 12-10
0 PLC ± -		PRODUCT SPEC	
1 PLC ± -		APPLICATION SPEC	
2 PLC ± 0.20 [.008]		114-2157	SIZE CAGE CODE DRAWING NO RESTRICTED TO
3 PLC ± -		WEIGHT -	A3 00779 C-696072
4 PLC ± -			
ANGLES ± -			
FINISH			
SEE TABLE			
SEE TABLE			
CUSTOMER DRAWING			SCALE 5:1 SHEET 1 OF 1 REV C