



Chipsmall Limited consists of a professional team with an average of over 10 year of expertise in the distribution of electronic components. Based in Hongkong, we have already established firm and mutual-benefit business relationships with customers from,Europe,America and south Asia,supplying obsolete and hard-to-find components to meet their specific needs.

With the principle of “Quality Parts,Customers Priority,Honest Operation,and Considerate Service”,our business mainly focus on the distribution of electronic components. Line cards we deal with include Microchip,ALPS,ROHM,Xilinx,Pulse,ON,Everlight and Freescale. Main products comprise IC,Modules,Potentiometer,IC Socket,Relay,Connector.Our parts cover such applications as commercial,industrial, and automotives areas.

We are looking forward to setting up business relationship with you and hope to provide you with the best service and solution. Let us make a better world for our industry!



Contact us

Tel: +86-755-8981 8866 Fax: +86-755-8427 6832

Email & Skype: info@chipsmall.com Web: www.chipsmall.com

Address: A1208, Overseas Decoration Building, #122 Zhenhua RD., Futian, Shenzhen, China



General information

IGBT Stack for typical voltages of up to 690 V_{RMS}
Rated output current 1800 A_{RMS}

- High power converter
- Wind power
- Motor drives
- PrimePACK™3 module with integrated NTC
- Extended operational temperature
- Low V_{cesat}

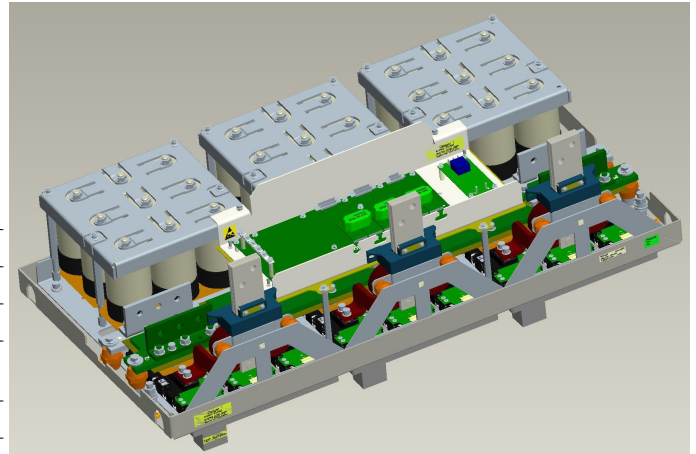

Topology	B6I
Application	Inverter
Load type	Resistive, inductive
Semiconductor (Inverter Section)	9x FF1000R17IE4
DC Link	10.8 mF
Heatsink	Water cooled
Implemented sensors	Current, voltage, temperature
Driver signals IGBT	Electrical
Sales - name	6MS30017E43W40372
SP - No.	SP001200194

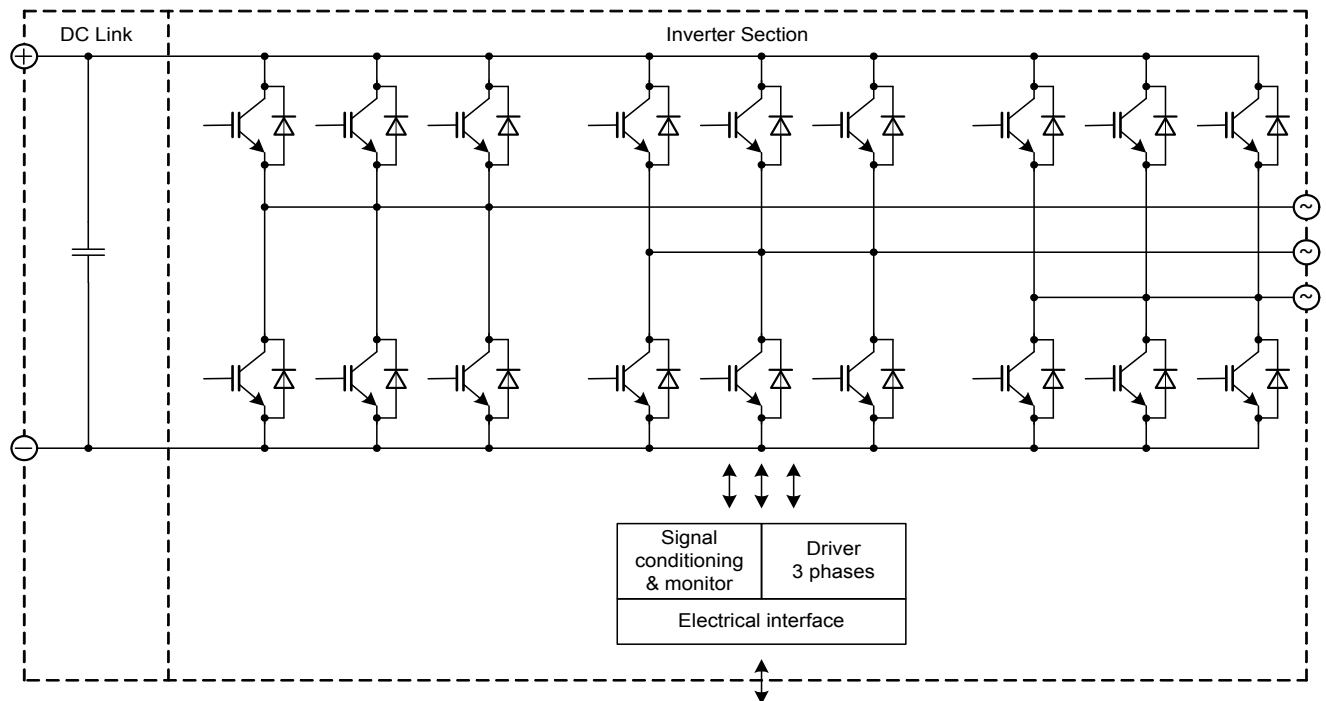

prepared by: OW	date of publication: 2014-02-13
approved by: KV	revision: 2.0

Technical Information

ModSTACK™ HD

6MS30017E43W40372



Preliminary data

Absolute maximum rated values

Collector-emitter voltage	IGBT; $T_{vj} = 25^{\circ}\text{C}$	V_{CES}	1700	V
Repetitive peak reverse voltage	Diode; $T_{vj} = 25^{\circ}\text{C}$	V_{RRM}	1700	V
DC link voltage		V_{DC}	1250	V
Insulation management	according to installation height of 2000 m	V_{line}	690	V_{RMS}
Insulation test voltage	according to EN 50178, $f = 50\text{ Hz}$, $t = 1\text{ s}$	V_{ISOL}	2.5	kV_{RMS}
Repetitive peak collector current inverter section (IGBT)	$t_p = 1\text{ ms}$	I_{CRM2}	4280	A
Repetitive peak forward current inverter section (Diode)	$t_p = 1\text{ ms}$	I_{FRM2}	4280	A
Continuous current inverter section		I_{AC2}	1800	A_{RMS}
Junction temperature	under switching conditions	T_{vjop}	150	$^{\circ}\text{C}$
Switching frequency inverter section		f_{sw2}	3	kHz

Notes

Further maximum ratings are specified in the following dedicated sections

Characteristic values

DC Link

			min.	typ.	max.	
Rated voltage		V_{DC}		1100	1216	V
Over voltage shutdown	within 150 μs			1250		V
Capacitor	1 s, 27 p, rated tol. $\pm 10\%$	C_{DC}		10.8		mF
		type	Foil			
Maximum ripple current	per device, $T_{amb} = 55^{\circ}\text{C}$	I_{ripple}			49	A_{RMS}
Balance or discharge resistor	per DC link unit	R_b		15.7		$k\Omega$

Notes

Operation above 1100 V subject to reduced operating time according to EN 61071

Inverter Section

			min.	typ.	max.	
Rated continuous current	$V_{DC} = 1100\text{ V}$, $V_{AC} = 690\text{ V}_{RMS}$, $\cos(\varphi) = 0.85$, $f_{AC\ sine} = 50\text{ Hz}$, $f_{sw} = 3000\text{ Hz}$, $T_{inlet} = 40^{\circ}\text{C}$, $T_j \leq 150^{\circ}\text{C}$	I_{AC}			1800	A_{RMS}
Continuous current at low frequency	$V_{DC} = 1100\text{ V}$, $f_{AC\ sine} = 0\text{ Hz}$, $f_{sw} = 3000\text{ Hz}$, $T_{inlet} = 40^{\circ}\text{C}$, $T_j \leq 150^{\circ}\text{C}$	$I_{AC\ low}$			880	A_{RMS}
Rated continuous current for 150% overload capability	$I_{AC\ 150\%} = 2047\text{ A}_{RMS}$, $t_{on\ over} = 60\text{ s}$, $T_j \leq 150^{\circ}\text{C}$	$I_{AC\ over1}$			1365	A_{RMS}
Rated continuous current for 150% overload capability	$I_{AC\ 150\%} = 2203\text{ A}_{RMS}$, $t_{on\ over} = 3\text{ s}$, $T_j \leq 150^{\circ}\text{C}$	$I_{AC\ over2}$			1468	A_{RMS}
Over current shutdown	within 15 μs	$I_{AC\ OC}$		4280		A_{peak}
Power losses	$I_{AC} = 1800\text{ A}$, $V_{DC} = 1100\text{ V}$, $V_{AC} = 690\text{ V}_{RMS}$, $\cos(\varphi) = 0.85$, $f_{AC\ sine} = 50\text{ Hz}$, $f_{sw} = 3000\text{ Hz}$, $T_{inlet} = 40^{\circ}\text{C}$, $T_j \leq 150^{\circ}\text{C}$	P_{loss}		29140		W

prepared by: OW

date of publication: 2014-02-13

approved by: KV

revision: 2.0

Technical Information

ModSTACK™ HD

6MS30017E43W40372



Preliminary data

Controller interface

Driver and interface board	ref. to separate Application Note		DR110			
			min.	typ.	max.	
Auxiliary voltage		V_{aux}	18	24	30	V
Auxiliary power requirement	$V_{aux} = 24\text{ V}$	P_{aux}		40		W
Digital input level	resistor to GND 1.8 kΩ, capacitor to GND 4 nF, logic high = on, min. 15 mA	$V_{in\ low}$	0		4	V
		$V_{in\ high}$	11		15	V
Digital output level	open collector, logic low = no fault, max. 15 mA	$V_{out\ low}$	0		1.5	V
		$V_{out\ high}$		15		V
Analog current sensor output inverter section	load max 1 mA, @ 1800 A_{RMS}	$V_{IU\ ana2}$ $V_{IV\ ana2}$ $V_{IW\ ana2}$	4.1	4.2	4.3	V
Analog DC link voltage sensor output	load max 1 mA, @ 1100 V	$V_{DC\ ana}$	7.7	7.9	8.1	V
Analog temperature sensor output inverter section (NTC)	load max 1 mA, @ $T_{NTC} = 62\text{ °C}$, corresponds to $T_j = 135\text{ °C}$ at rated conditions	$V_{Theta\ NTC2}$		7.2		V
Analog temperature sensor output inverter section (Simulated)	load max 1 mA, @ $T_{NTC} = 62\text{ °C}$, corresponds to $T_j = 135\text{ °C}$ at rated conditions	$V_{Theta\ sim2}$		8.9		V
Over temperature shutdown inverter section		$V_{Error\ OT2}$		9.2		V

System data

			min.	typ.	max.	
EMC robustness	according to IEC 61800-3 at named interfaces	power	V_{Burst}	2		kV
		control	V_{Burst}	1		kV
		aux (24V)	V_{surge}	1		kV
Storage temperature		T_{stor}	-40		80	°C
Operational ambient temperature	PCB, DC link capacitor, bus bar, excluding cooling medium	$T_{op\ amb}$	-25		55	°C
Cooling air velocity	PCB, DC link capacitor, bus bar, standard atmosphere	V_{air}	2			m/s
Humidity	no condensation	Rel. F	0		95	%
Vibration	according to IEC 60721				5	m/s ²
Shock	according to IEC 60721				40	m/s ²
Protection degree			IP00			
Pollution degree			2			
Dimensions	width x depth x height		1090	596	339	mm
Weight				137		kg

Heatsink water cooled

			min.	typ.	max.	
Water flow	according to coolant specification from Infineon	$\Delta V/\Delta t$	45			dm ³ /min
Water pressure					8	bar
Water pressure drop	at 45 dm ³ /min water flow	Δp		200		mbar
Coolant inlet temperature		T_{inlet}	-40		55	°C
Thermal resistance heatsink to ambient	per switch	$R_{th,ha}$		0.03		K/W
Cooling channel material			Aluminum			

Notes

Composition of coolant: Water and 52 vol. % Antifrogen N

prepared by: OW	date of publication: 2014-02-13
approved by: KV	revision: 2.0

Technical Information

ModSTACK™ HD

6MS30017E43W40372



Preliminary data

Overview of optional components

	Unit 1 (not installed)	Inverter Section	Unit 3 (not installed)
Parallel interface board			
Optical interface board			
Voltage sensor		x	
Current sensor		x	
Temperature sensor		x	
Temperature simulation		x	
DC link capacitors		x	
Collector-emitter Active Clamping		x	

Notes

Setting of Active Clamping TVS-Diodes: $V_z = 1280\text{ V}$

prepared by: OW	date of publication: 2014-02-13
approved by: KV	revision: 2.0

Preliminary data

$f_{AC\ sine}$ - derating curve IGBT (motor), Diode (generator)
 $V_{DC} = 1100\ V$, $V_{AC} = 690\ V_{RMS}$, $f_{sw} = 3\ kHz$, $\cos\phi = \pm 0.85$,
 $T_{inlet} = 40\ ^\circ C$ and nom. cooling conditions

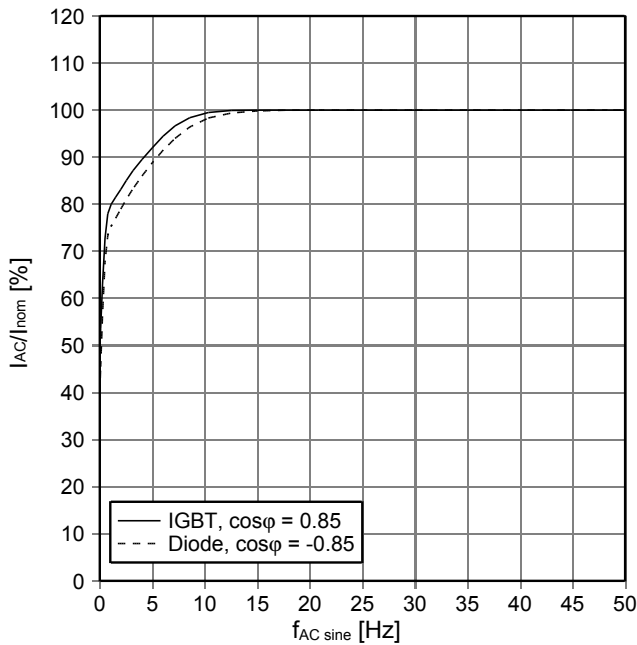

f_{sw} - derating curve IGBT (motor), Diode (generator)
 $V_{DC} = 1100\ V$, $V_{AC} = 690\ V_{RMS}$, $f_{AC\ sine} = 50\ Hz$, $\cos\phi = \pm 0.85$,
 $T_{inlet} = 40\ ^\circ C$ and nom. cooling conditions

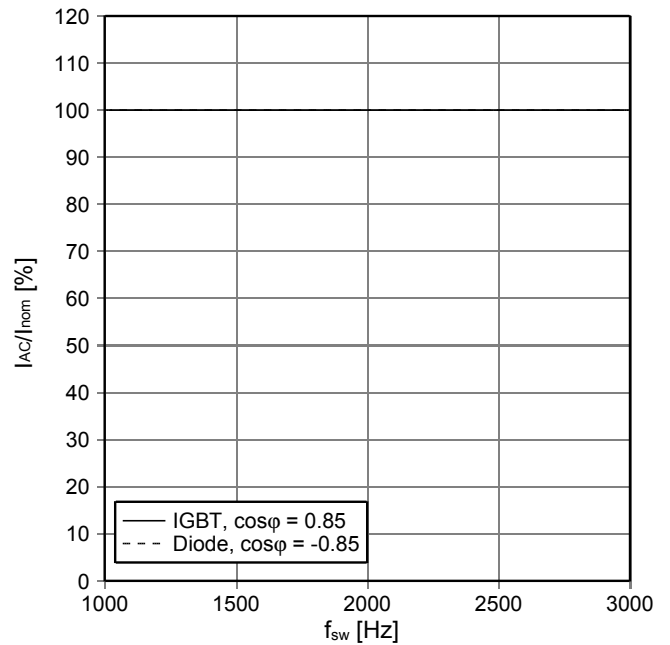

T_{inlet} - derating curve IGBT (motor), Diode (generator)
 $V_{DC} = 1100\ V$, $V_{AC} = 690\ V_{RMS}$, $f_{sw} = 3\ kHz$, $f_{AC\ sine} = 50\ Hz$,
 $\cos\phi = \pm 0.85$ and nom. cooling conditions

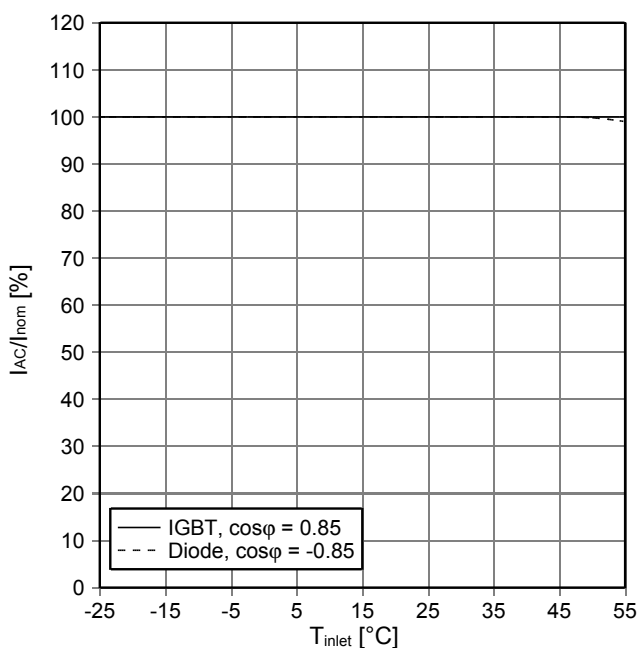

Analog temperature sensor output $V_{Theta\ NTC}$
 Sensing NTC of IGBT module

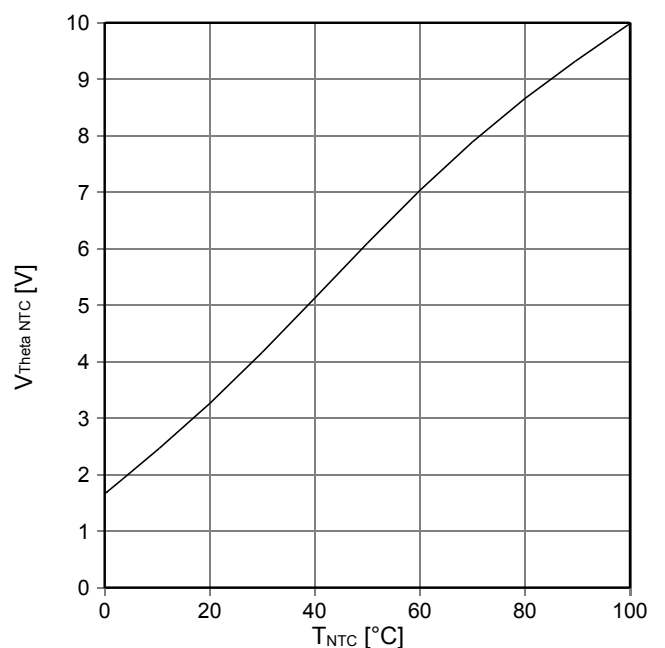

prepared by: OW	date of publication: 2014-02-13
approved by: KV	revision: 2.0

Preliminary data

$T_{vj, sim}$ vs. I_{AC} - Simulated junction temperatur
 $V_{DC} = 1100\text{ V}$, $V_{AC} = 690\text{ V}_{RMS}$, $f_{sw} = 3\text{ kHz}$,
 $T_{inlet} = 40\text{ °C}$ and nom. cooling conditions

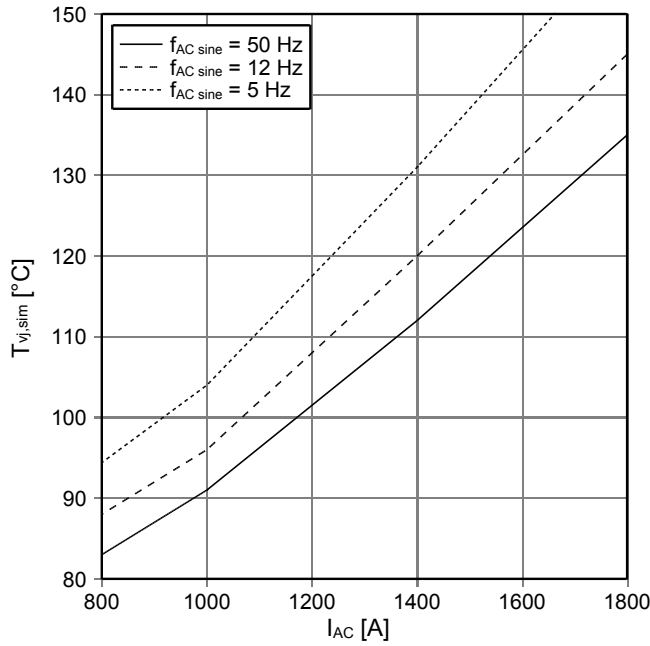

Analog temperature sensor output $V_{Theta\ sim}$
 $V_{DC} = 1100\text{ V}$, $V_{AC} = 690\text{ V}_{RMS}$, $f_{sw} = 3\text{ kHz}$,
 nom. cooling conditions

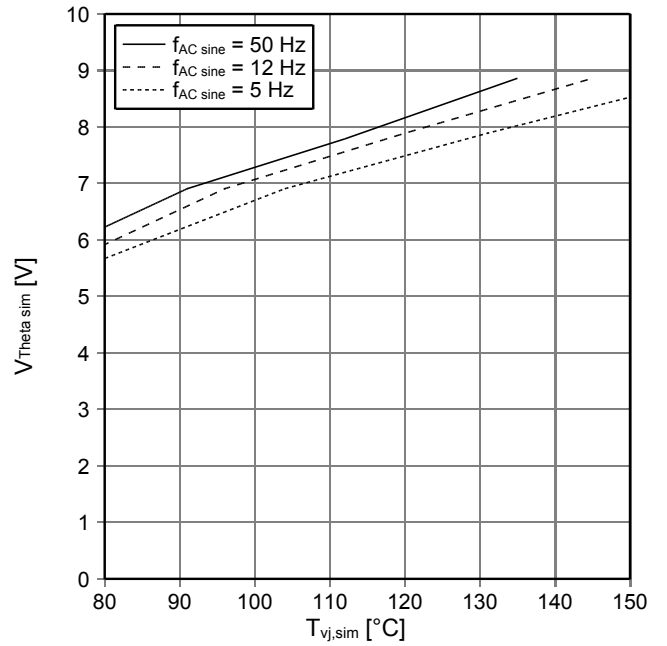

$Z_{th, ha}$ - thermal impedance heatsink to ambient per switch
 nom. cooling conditions

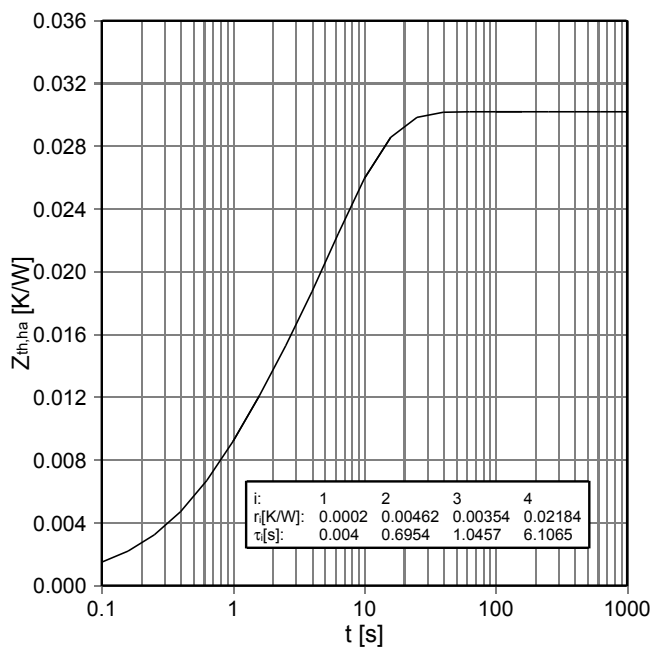

prepared by: OW	date of publication: 2014-02-13
approved by: KV	revision: 2.0

Mechanical drawing

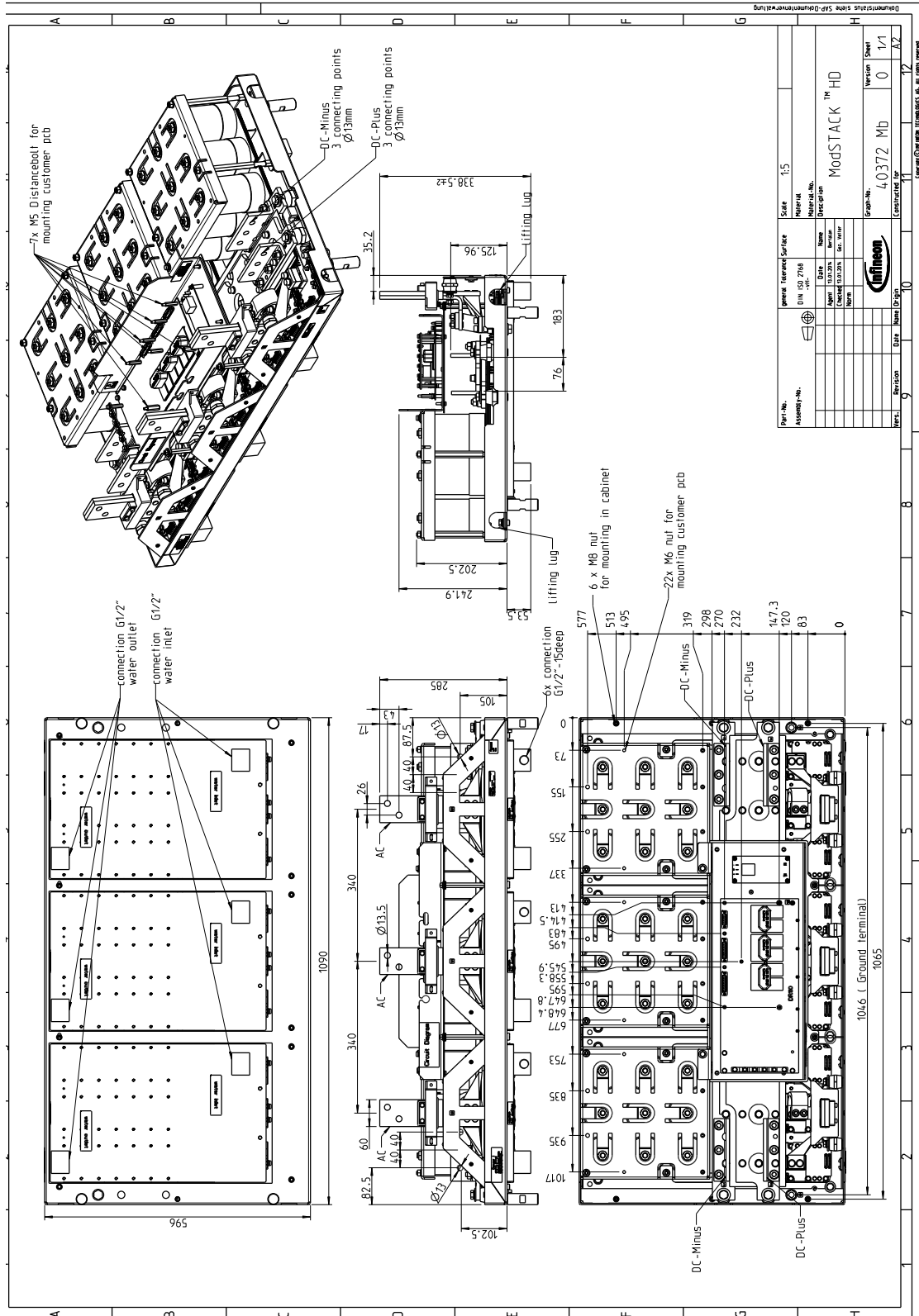

prepared by: OW	date of publication: 2014-02-13
approved by: KV	revision: 2.0

Circuit diagram

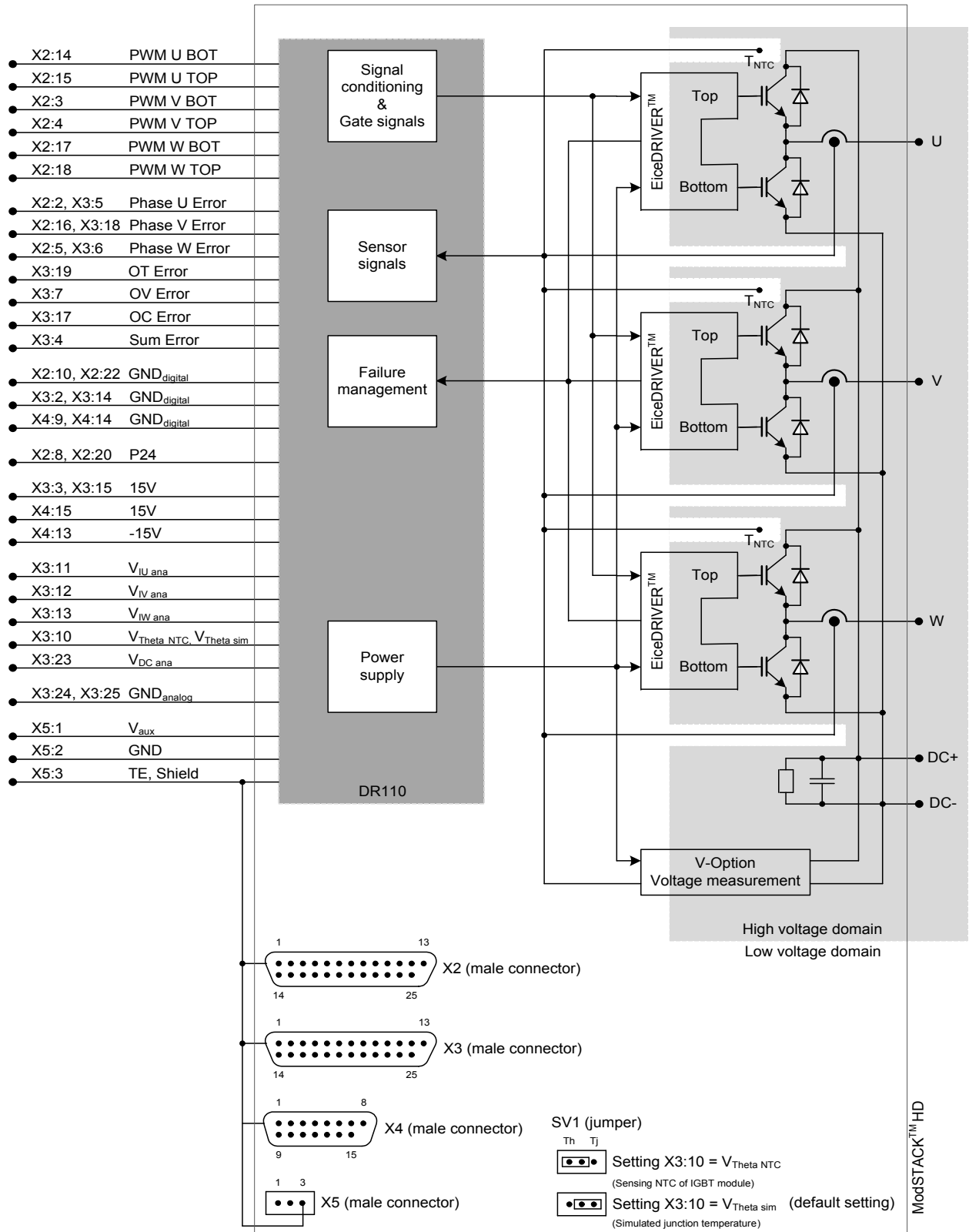

prepared by: OW	date of publication: 2014-02-13
approved by: KV	revision: 2.0

Technical Information

ModSTACK™ HD

6MS30017E43W40372



Preliminary data

Terms & Conditions of usage

The data contained in this product data sheet is exclusively intended for technically trained staff. You and your technical departments will have to evaluate the suitability of the product for the intended application and the completeness of the product data with respect to such application.

This product data sheet is describing the characteristics of this product for which a warranty is granted. Any such warranty is granted exclusively pursuant to the terms and conditions of the supply agreement. There will be no guarantee of any kind for the product and its characteristics.

Should you require product information in excess of the data given in this product data sheet or which concerns the specific application of our product, please contact the sales office, which is responsible for you (see www.infineon.com, sales&contact). For those that are specifically interested we may provide application notes.

Due to technical requirements our product may contain dangerous substances. For information on the types in question please contact the sales office, which is responsible for you.

Should you intend to use the Product in aviation applications, in health or live endangering or life support applications, please notify. Please note, that for any such applications we urgently recommend

- to perform joint Risk and Quality Assessments;
- the conclusion of Quality Agreements;
- to establish joint measures of an ongoing product survey, and that we may make delivery depended on the realization of any such measures.

If and to the extent necessary, please forward equivalent notices to your customers.

Changes of this product data sheet are reserved.

Safety Instructions

Prior to installation and operation, all safety notices and warnings and all warning signs attached to the equipment have to be carefully read. Make sure that all warning signs remain in a legible condition and that missing or damaged signs are replaced. To installation and operation, all safety notices and warnings and all warning signs attached to the equipment have to be carefully read. Make sure that all warning signs remain in a legible condition and that missing or damaged signs are replaced.

prepared by: OW	date of publication: 2014-02-13
approved by: KV	revision: 2.0