



Chipsmall Limited consists of a professional team with an average of over 10 year of expertise in the distribution of electronic components. Based in Hongkong, we have already established firm and mutual-benefit business relationships with customers from,Europe,America and south Asia,supplying obsolete and hard-to-find components to meet their specific needs.

With the principle of “Quality Parts,Customers Priority,Honest Operation,and Considerate Service”,our business mainly focus on the distribution of electronic components. Line cards we deal with include Microchip,ALPS,ROHM,Xilinx,Pulse,ON,Everlight and Freescale. Main products comprise IC,Modules,Potentiometer,IC Socket,Relay,Connector.Our parts cover such applications as commercial,industrial, and automotives areas.

We are looking forward to setting up business relationship with you and hope to provide you with the best service and solution. Let us make a better world for our industry!



Contact us

Tel: +86-755-8981 8866 Fax: +86-755-8427 6832

Email & Skype: info@chipsmall.com Web: www.chipsmall.com

Address: A1208, Overseas Decoration Building, #122 Zhenhua RD., Futian, Shenzhen, China



THIS DRAWING IS UNPUBLISHED. RELEASED FOR PUBLICATION
 © COPYRIGHT BY TYCO ELECTRONICS CORPORATION. ALL RIGHTS RESERVED.

LOC	DIST	REVISIONS			
P	LTR	DESCRIPTION	DATE	DWN	APVD
	B	REVISED PER 0G3B-0339-04	4/14/04	SS	SRY

- NOTES:
- 1. MATERIAL:
COVER: RIGID PVC, UL94V-0, COLOR CLEAR.
CLIP: NYLON, UL94V-0, COLOR BLACK
 - 2. FOR USE WITH BC6 TRIBARRIER STRIPS.
 - 3. MOUNTING HARDWARE NOT INCLUDED.
 - 4. PRELIMINARY PART NUMBER.

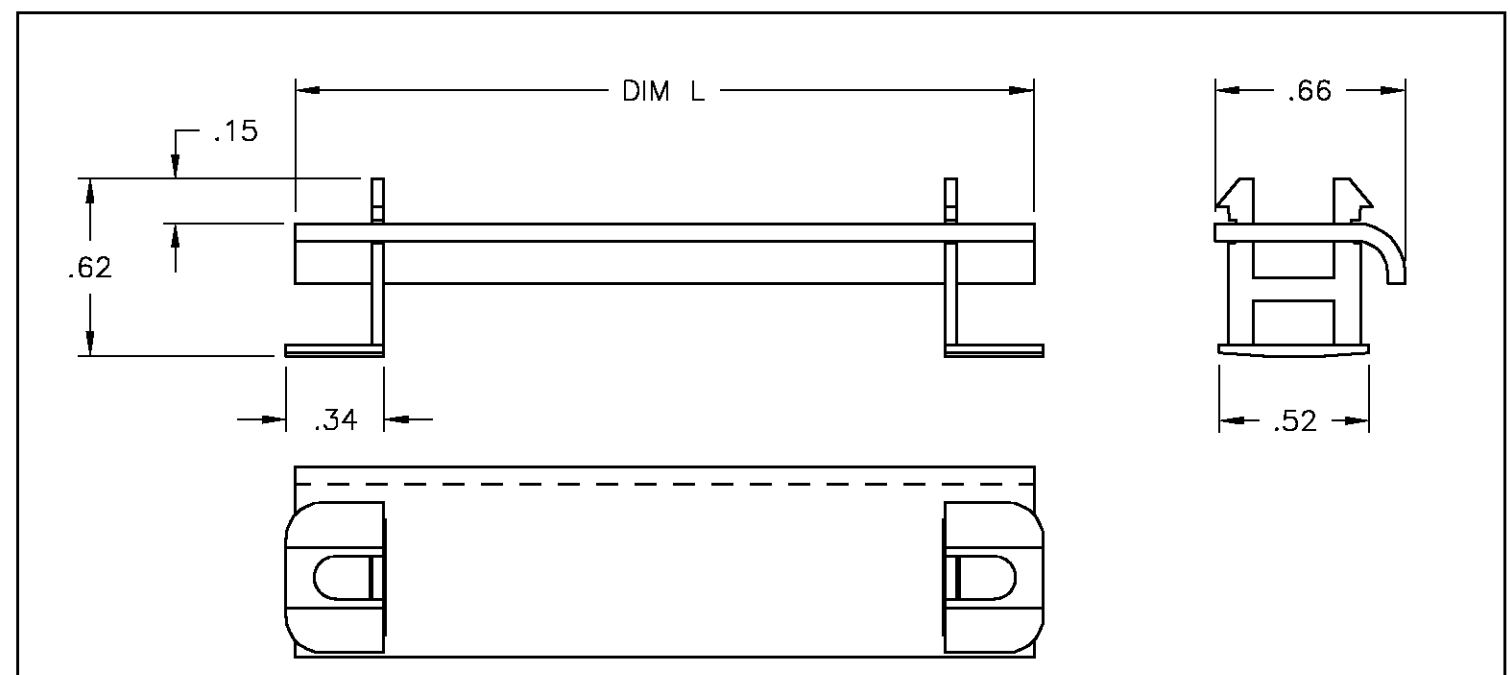
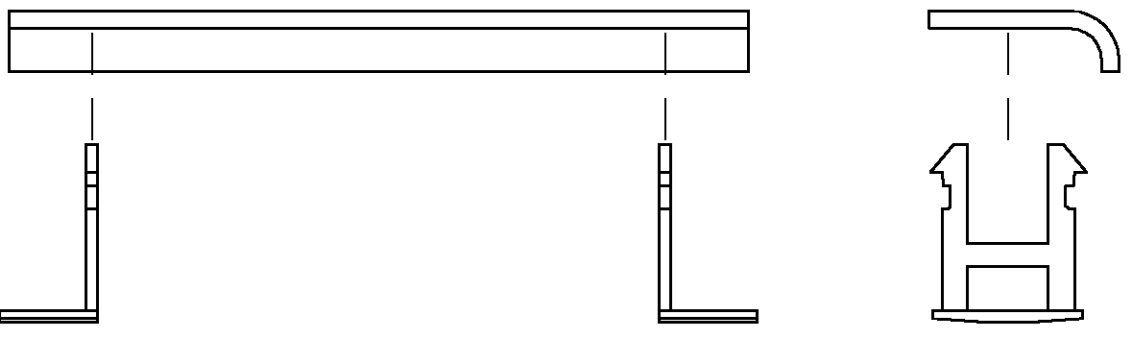
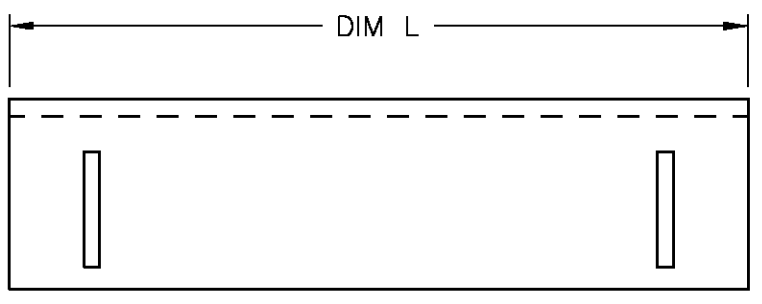

ASSEMBLED VIEW

DIM L	NO OF POS.	CATALOG NUMBER	PART NUMBER
10.440	26	TC2-26-AG	2-1546835-6
10.065	25	TC2-25-AG	2-1546835-5
9.690	24	TC2-24-AG	2-1546835-4
9.315	23	TC2-23-AG	2-1546835-3
8.940	22	TC2-22-AG	2-1546835-2
8.565	21	TC2-21-AG	2-1546835-1
8.190	20	TC2-20-AG	2-1546835-0
7.815	19	TC2-19-AG	1-1546835-9
7.440	18	TC2-18-AG	1-1546835-8
7.065	17	TC2-17-AG	1-1546835-7
6.690	16	TC2-16-AG	1-1546835-6
6.315	15	TC2-15-AG	1-1546835-5
5.940	14	TC2-14-AG	1-1546835-4
5.565	13	TC2-13-AG	7-1437644-7
5.190	12	TC2-12-AG	1-1546835-2
4.815	11	TC2-11-AG	1-1546835-1
4.440	10	TC2-10-AG	1-1546835-0
4.065	9	TC2-09-AG	1546835-9
3.690	8	TC2-08-AG	7-1437644-5
3.315	7	TC2-07-AG	1546835-7
2.940	6	TC2-06-AG	7-1437644-4
2.565	5	TC2-05-AG	7-1437644-3
2.190	4	TC2-04-AG	1546835-4
1.815	3	TC2-03-AG	7-1437644-2
1.440	2	TC2-02-AG	7-1437644-1

THIS DRAWING IS A CONTROLLED DOCUMENT.		DWN S SCHEGEL 08OCT03	BUCHANAN Tyco Electronics Corporation Harrisburg, PA 17105	
DIMENSIONS: INCHES 		CHK S YODER 10/8/03		
TOLERANCES UNLESS OTHERWISE SPECIFIED: 0 PLC ± - 1 PLC ± - 2 PLC ± .01 3 PLC ± .005 4 PLC ± - ANGLES ± 1°		APVD S YODER 10/8/03	NAME TC2 TERMINAL COVER KIT (UNASSEMBLED)	
MATERIAL		PRODUCT SPEC	SIZE	
FINISH		APPLICATION SPEC	CAGE CODE	DRAWING NO
		WEIGHT	RESTRICTED TO	
		A3 00779 C-7-1437644-1		
CUSTOMER DRAWING		SCALE	SHEET	REV
		NTS	1 OF 1	B