



Chipsmall Limited consists of a professional team with an average of over 10 year of expertise in the distribution of electronic components. Based in Hongkong, we have already established firm and mutual-benefit business relationships with customers from,Europe,America and south Asia,supplying obsolete and hard-to-find components to meet their specific needs.

With the principle of "Quality Parts,Customers Priority,Honest Operation,and Considerate Service",our business mainly focus on the distribution of electronic components. Line cards we deal with include Microchip,ALPS,ROHM,Xilinx,Pulse,ON,Everlight and Freescale. Main products comprise IC,Modules,Potentiometer,IC Socket,Relay,Connector.Our parts cover such applications as commercial,industrial, and automotives areas.

We are looking forward to setting up business relationship with you and hope to provide you with the best service and solution. Let us make a better world for our industry!



Contact us

Tel: +86-755-8981 8866 Fax: +86-755-8427 6832

Email & Skype: info@chipsmall.com Web: www.chipsmall.com

Address: A1208, Overseas Decoration Building, #122 Zhenhua RD., Futian, Shenzhen, China



THIS DRAWING IS UNPUBLISHED. RELEASED FOR PUBLICATION
 © COPYRIGHT - By - ALL RIGHTS RESERVED.

LOC		DIST		REVISIONS			
P	LTR	DESCRIPTION		DATE	DWN	APVD	
GP	00	AR4	REVISED PER ECO-11-004835	11MAR11	RK	HMR	

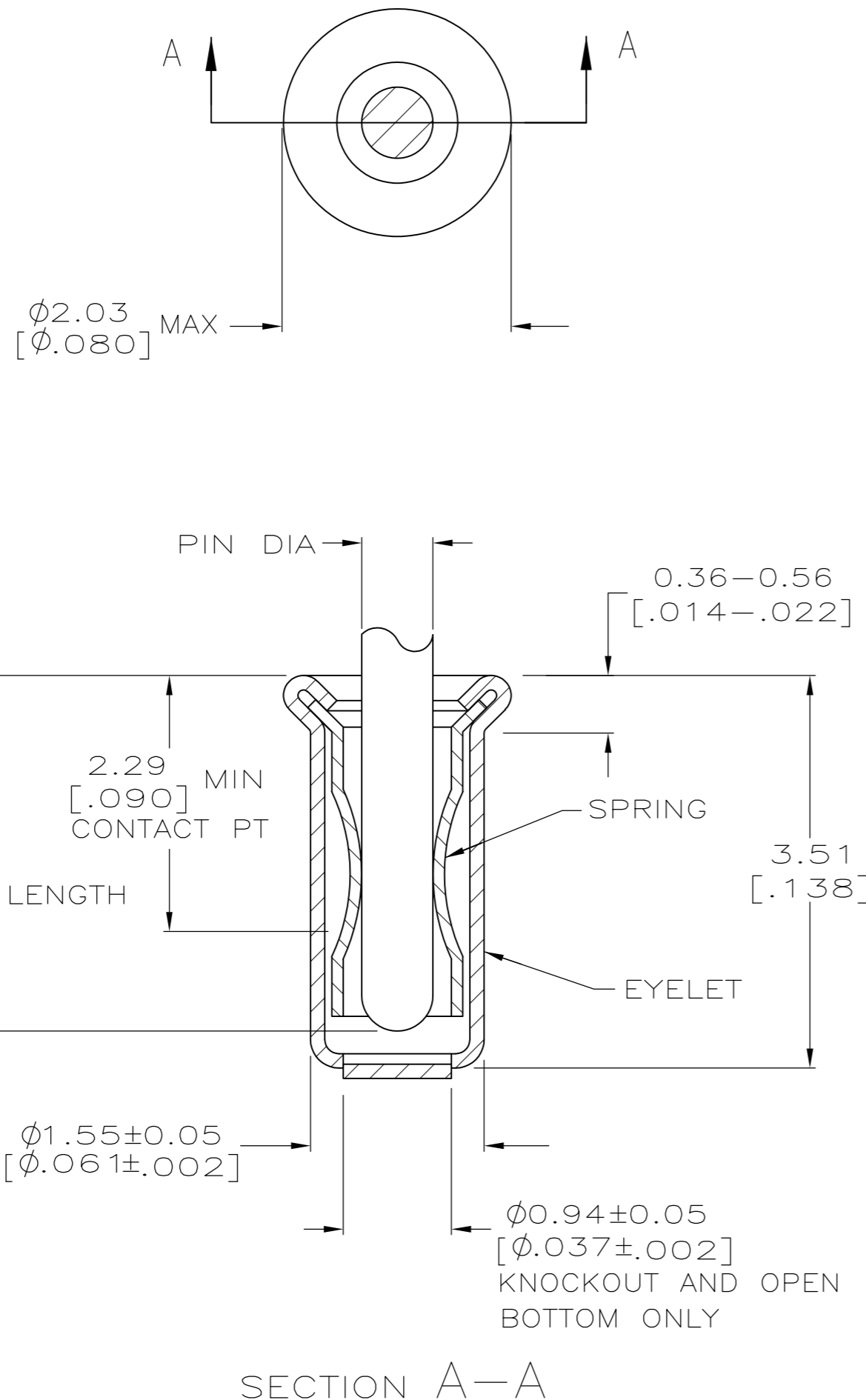

- 1. TIN PER MIL-T-10727 OR TIN LEAD 0.00254 [.000100] MIN THK.
- 2. GOLD PER MIL-G-45204, TYPE II, 0.00076 [.000030] MIN THK OVER NICKEL PER QQ-N-290 0.00028 [.000011] MIN THK ON CONTACT AREA.
- 3. GOLD FLASH PER MIL-G-45204, TYPE II, 0.13 μm [.000005] MIN THK. OVER NICKEL PLATE PER QQ-N-290 0.51 μm-1.52 μm [.000020-.000060] EXT THK.
- 4. TIN PER MIL-T-10727 OR TIN LEAD 0.00381 [.000150] MIN THK.
- 5. RECOMMENDED HOLE SIZE, PLATED OR UNPLATED:
 MACHINE INSERTION: 1.57 ^{+0.10}/_{-0.08} [.062 ^{+0.004}/_{-0.003}]
 HAND INSERTION: 1.60 ^{+0.10}/_{-0.00} [.063 ^{+0.004}/_{-0.000}]
- 6. APPLICATION TOOL PART NUMBER: MACHINE NO. 682127-4
 INSERTION HEAD NO. 682039-3
- 7. TO INSURE PROPER SPRING TENSION DO NOT EXCEED A 0.05 [.002] DIFFERENCE IN PIN DIA WHEN CHANGING TO A SMALLER PIN.
- 8. BOTTOM PLUG KNOCKOUT TOOL PART NUMBER 69729 WITH TIP PART NUMBER 69728-1.
- 9. TIN PER ASTM B 545, 0.00254 [.000100] MIN THK.

- 10 MATERIAL: SPRING COPPER QQ-C-533 EYELET: COPPER QQ-C-576
- 11 OBSOLETE PARTS: OBSOLETE CIS STREAMLINING PER D.RENAUD/D.SINISI

9	CLOSED	0.76-0.84 [.030-.033]	TIN 9	TIN 9	8-331677-3
	OPEN	0.76-0.84 [.030-.033]	TIN 4	GOLD 2	7-331677-4
OBSOLETE		0.76-0.84 [.030-.033]	TIN 1		7-331677-3
OBSOLETE					7-331677-1
OBSOLETE	CLOSED	0.66-0.74 [.026-.029]		GOLD 2	3-331677-8
OBSOLETE		0.56-0.64 [.022-.025]	TIN 1	TIN 1	3-331677-7
OBSOLETE	KNOCKOUT	0.76-0.84 [.030-.033]			3-331677-5
OBSOLETE		0.66-0.74 [.026-.029]			3-331677-4
OBSOLETE		0.76-0.84 [.030-.033]	GOLD 3	GOLD 2	3-331677-2
OBSOLETE		0.66-0.74 [.026-.029]			3-331677-0
11 OBSOLETE		0.76-0.84 [.030-.033]			2-331677-9
		0.66-0.74 [.026-.029]			2-331677-7
		0.76-0.84 [.030-.033]			2-331677-6
		0.66-0.74 [.026-.029]			2-331677-4
	OPEN				2-331677-3
		0.76-0.84 [.030-.033]	TIN 1	GOLD 2	2-331677-2
		0.56-0.64 [.022-.025]		TIN 1	2-331677-1
		0.76-0.84 [.030-.033]		GOLD 2	2-331677-0
		0.56-0.64 [.022-.025]		TIN 1	1-331677-9
	CLOSED	0.76-0.84 [.030-.033]		GOLD 2	1-331677-8
		0.56-0.64 [.022-.025]	GOLD 3	TIN 1	1-331677-7
		0.76-0.84 [.030-.033]	TIN 1	TIN 1	1-331677-6
		0.56-0.64 [.022-.025]	GOLD 3	GOLD 2	1-331677-4
		0.76-0.84 [.030-.033]	TIN 1	TIN 1	1-331677-3
		0.66-0.74 [.026-.029]	GOLD 3	GOLD 2	1-331677-1
		0.66-0.74 [.026-.029]	TIN 1	TIN 1	1-331677-0
	BOTTOM TYPE	RECOMMENDED PIN DIA	EYELET	SPRING	PART NO

THIS DRAWING IS A CONTROLLED DOCUMENT. DWN R. TALLEY 4-5-91
 CHK -
 APVD -

DIMENSIONS: mm [INCHES]	TOLERANCES UNLESS OTHERWISE SPECIFIED:	PRODUCT SPEC	NAME
0 PLC ± -	1 PLC ± -	APPLICATION SPEC	MINIATURE SPRING SOCKRT ASSEMBLY
2 PLC ± -	3 PLC ± 0.20 [.008]		
4 PLC ± -	ANGLES ± -	WEIGHT	SIZE CAGE CODE DRAWING NO RESTRICTED TO
MATERIAL	FINISH		A2 00779 C=331677
		CUSTOMER DRAWING	SCALE 1:1 SHEET 1 OF 1 REV AR4

TE Connectivity