



Chipsmall Limited consists of a professional team with an average of over 10 year of expertise in the distribution of electronic components. Based in Hongkong, we have already established firm and mutual-benefit business relationships with customers from,Europe,America and south Asia,supplying obsolete and hard-to-find components to meet their specific needs.

With the principle of “Quality Parts,Customers Priority,Honest Operation,and Considerate Service”,our business mainly focus on the distribution of electronic components. Line cards we deal with include Microchip,ALPS,ROHM,Xilinx,Pulse,ON,Everlight and Freescale. Main products comprise IC,Modules,Potentiometer,IC Socket,Relay,Connector.Our parts cover such applications as commercial,industrial, and automotives areas.

We are looking forward to setting up business relationship with you and hope to provide you with the best service and solution. Let us make a better world for our industry!



Contact us

Tel: +86-755-8981 8866 Fax: +86-755-8427 6832

Email & Skype: info@chipsmall.com Web: www.chipsmall.com

Address: A1208, Overseas Decoration Building, #122 Zhenhua RD., Futian, Shenzhen, China



SWITCH FUNCTION	
POS. 1	POS. 2
ON	(ON)
1-3	1-2

(ON)=MOMENTARY

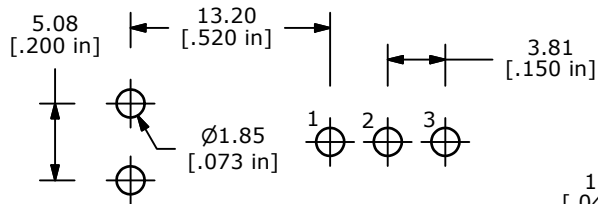

P.C. MOUNTING

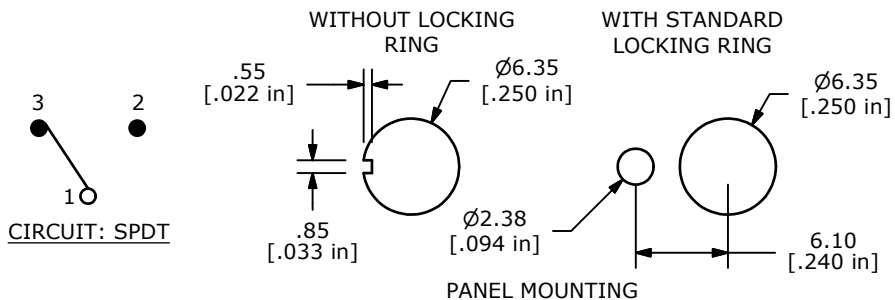
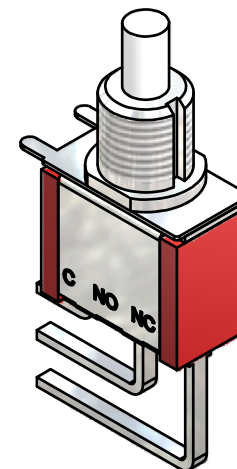
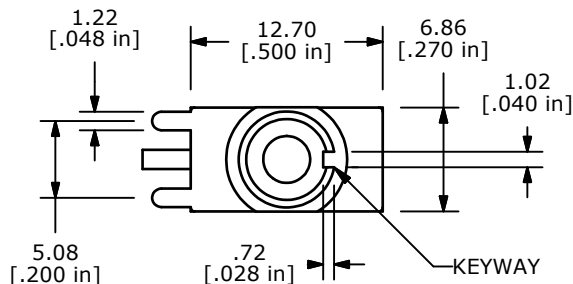

PANEL MOUNTING

NOTE:

1. ALL DIMENSIONS IN MM [INCH]
2. GENERAL TOLERANCE: X.X=±0.4
X.XX=±0.25
3. TERMINAL NUMBERS FOR REF ONLY
- ▲ 4. CONTACT MATERIAL: GOLD
5. RATING: 0.4VA MAX. @ 20 VAC OR VDC MAX.
6. ELECTRIC LIFE: 50,000 MAKE-AND-BREAK CYCLES AT FULL LOAD
7. INSULATION RESISTANCE: 1,000 MEGA-OHM MIN.
8. ACUATION FORCE: 300 ± 100gf
- ▲ 9. TRAVEL: 1.0 ± 0.2mm
10. CONTACT RESISTANCE: 20 mOHM MAX. TYPICAL @ 2-4 VDC
11. DIELECTRIC STRENGTH: 1,000 V RMS @ SEA LEVEL.
12. OPERATING TEMP.: -30°C to 85°C
13. ▲ DENOTES CRITICAL PARAMETER.
14. 2002/95/EC (ROHS) COMPLIANT.
15. HARDWARE TO BE SHIPPED BULK
T100000 - HEXNUT - QTY 2
T100011 - LOCKWASHER - QTY 1
T100015 - LOCKRING - QTY 1

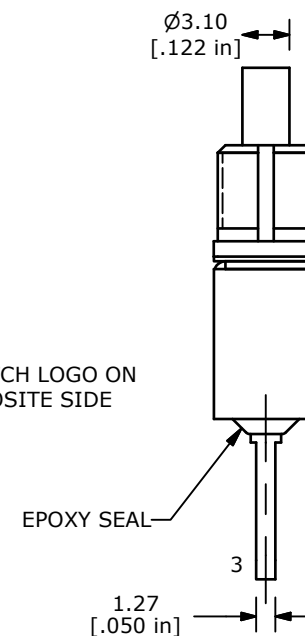
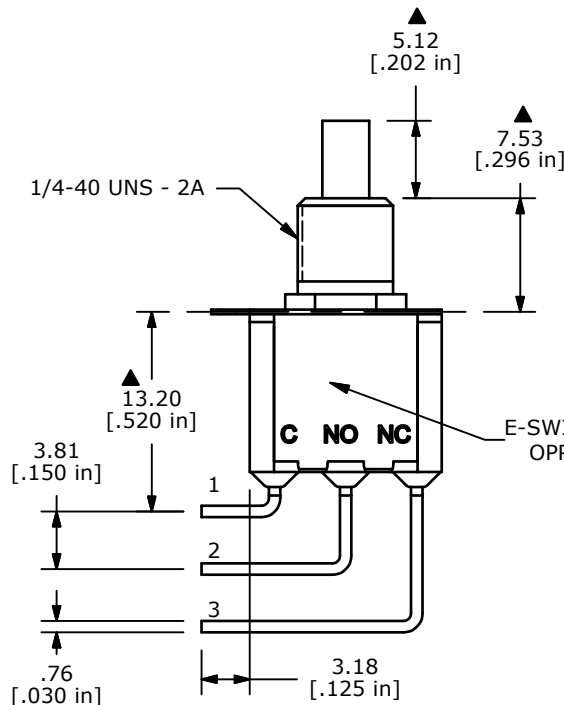

B	20032	DRAWING CLEAN-UP / UPDATE	6/27/11	BGL
A	16414	RELEASED FOR PRODUCTION	9/8/06	BO
REV	PCR NO	DESCRIPTION	DATE	BY

TITLE 700SP7B10M7REH				
SCALE 2:1	DATE 9/8/2006	DR BO	DWG ST711026	REV B

THE INFORMATION CONTAINED IN THIS DOCUMENT IS PROPRIETARY TO E-SWITCH AND IS NOT TO BE COPIED OR TRANSFERRED