



Chipsmall Limited consists of a professional team with an average of over 10 year of expertise in the distribution of electronic components. Based in Hongkong, we have already established firm and mutual-benefit business relationships with customers from,Europe,America and south Asia,supplying obsolete and hard-to-find components to meet their specific needs.

With the principle of "Quality Parts,Customers Priority,Honest Operation,and Considerate Service",our business mainly focus on the distribution of electronic components. Line cards we deal with include Microchip,ALPS,ROHM,Xilinx,Pulse,ON,Everlight and Freescale. Main products comprise IC,Modules,Potentiometer,IC Socket,Relay,Connector.Our parts cover such applications as commercial,industrial, and automotives areas.

We are looking forward to setting up business relationship with you and hope to provide you with the best service and solution. Let us make a better world for our industry!



Contact us

Tel: +86-755-8981 8866 Fax: +86-755-8427 6832

Email & Skype: info@chipsmall.com Web: www.chipsmall.com

Address: A1208, Overseas Decoration Building, #122 Zhenhua RD., Futian, Shenzhen, China



REVISIONS		
LTR	DESCRIPTION	DATE
C	REVISED PER ECD-08-016725	07/07/2008

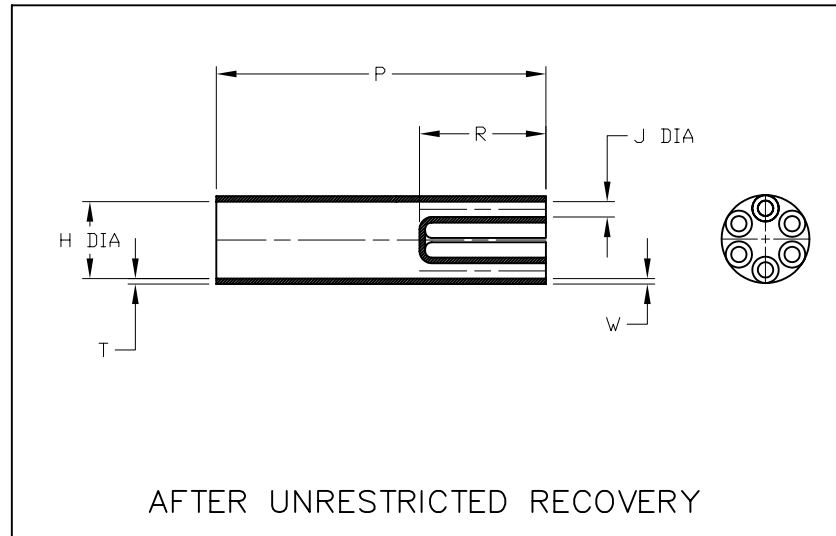
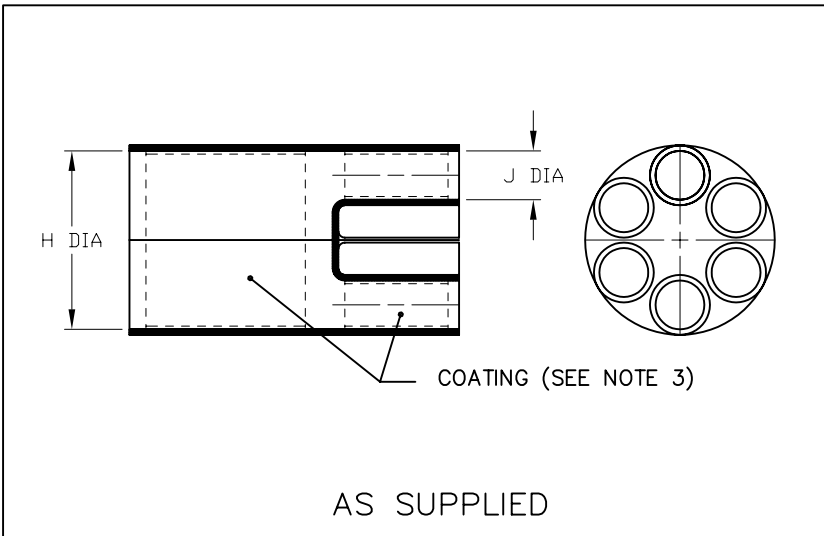

PART DESCRIPTION	H		J		P	R	T	W
	MIN	MAX	MIN	MAX	±10%	MIN	±20%	±20%
	a	b	a	b	b	b	b	b
703A155	<u>2.39</u> [60,7]	<u>1.45</u> [36,8]	<u>.80</u> [20,3]	<u>.35</u> [8,9]	<u>5.40</u> [137,2]	<u>2.00</u> [50,8]	<u>.14</u> [3,5]	<u>.10</u> [2,5]

NOTES

- ALL DIMENSIONS ARE IN $\frac{\text{INCHES}}{\text{MILLIMETERS}}$
- DIMENSIONS APPEARING IN TABLE ARE AS FOLLOWS:
 a - AS SUPPLIED
 b - AFTER UNRESTRICTED RECOVERY
- COATING IS OPTIONAL. AS SUPPLIED DIMENSIONS APPEARING IN TABLE ARE FOR UNCOATED PARTS. WHEN COATING IS ADDED, ENTRY DIAMETERS WILL BE REDUCED BY .06 MAX

If this document is printed it becomes uncontrolled. Check for the latest revision

CUSTOMER DRAWING

UNLESS OTHERWISE SPECIFIED DIMENSIONS ARE INCHES. METRIC DIMENSIONS ARE IN BRACKETS.	DRAWN	DATE		Raychem Molded Parts 305 Constitution Dr Menlo Park, CA 94025
	UNGUYEN	07/07/2008		
DECIMAL TOLERANCES	RPN	TITLE		
.XXX ± 0.005 [0.13 mm]	THIRD ANGLE PROJECTION	TRANSITION, 4 ENTRY		
.XX ± 0.01 [0.25 mm]		SIZE	CODE IDENT. NO.	DWG. NO.
.X ± 0.1 [0.50 mm]		B	06090	703A155
ANGLE TOLERANCE	DO NOT SCALE THIS DRAWING			SHEET 1 OF 2
.X ± 1 DEG.	© 2008 Tyco Electronics Corporation. All rights reserved.			

4

3

2

1

D

D

COMPATIBILITY CHART					
MATERIAL DASH NO.	MATERIAL DESCRIPTION	RT SPEC	COATING SLASH NO.	COATING SPEC	COATING DESCRIPTION
-3	POLYOLEFIN, SEMI-RIGID	RT-301	/42; /86;	S-1017; S-1048	ADHESIVE
-4	POLYOLEFIN, FLEXIBLE	RT-1304	/42; /86;	S-1017; S-1048	ADHESIVE
-25	ELASTOMER, FLUID RESISTANT	RT-1325	/42; /86;	S-1017; S-1048	ADHESIVE

C

C

B

B

ORDERING INFORMATION

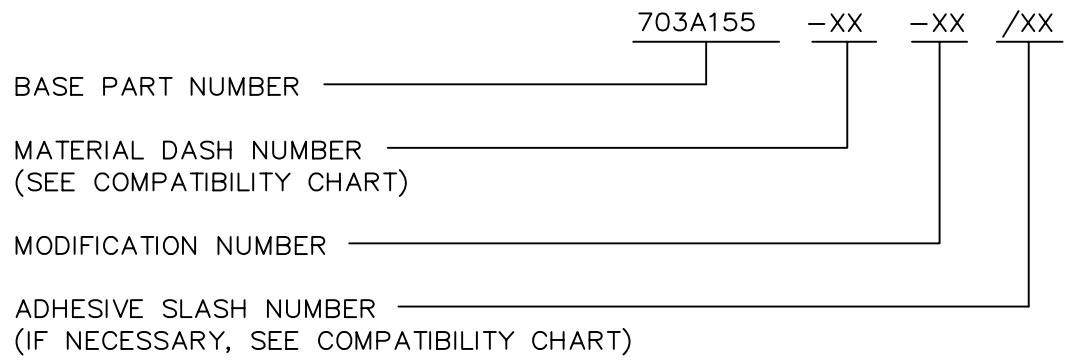

B

B

A

A

If this document is printed it becomes uncontrolled. Check for the latest revision

CUSTOMER DRAWING

SIZE	DWG. NO.	REV	DWG. NO.	
B	06090	C		703A155
DO NOT SCALE THIS DRAWING			SHEET 2 OF 2	

4

3

2

1