



Chipsmall Limited consists of a professional team with an average of over 10 year of expertise in the distribution of electronic components. Based in Hongkong, we have already established firm and mutual-benefit business relationships with customers from,Europe,America and south Asia,supplying obsolete and hard-to-find components to meet their specific needs.

With the principle of “Quality Parts,Customers Priority,Honest Operation,and Considerate Service”,our business mainly focus on the distribution of electronic components. Line cards we deal with include Microchip,ALPS,ROHM,Xilinx,Pulse,ON,Everlight and Freescale. Main products comprise IC,Modules,Potentiometer,IC Socket,Relay,Connector.Our parts cover such applications as commercial,industrial, and automotives areas.

We are looking forward to setting up business relationship with you and hope to provide you with the best service and solution. Let us make a better world for our industry!



## Contact us

Tel: +86-755-8981 8866 Fax: +86-755-8427 6832

Email & Skype: info@chipsmall.com Web: www.chipsmall.com

Address: A1208, Overseas Decoration Building, #122 Zhenhua RD., Futian, Shenzhen, China



UNIT : mm

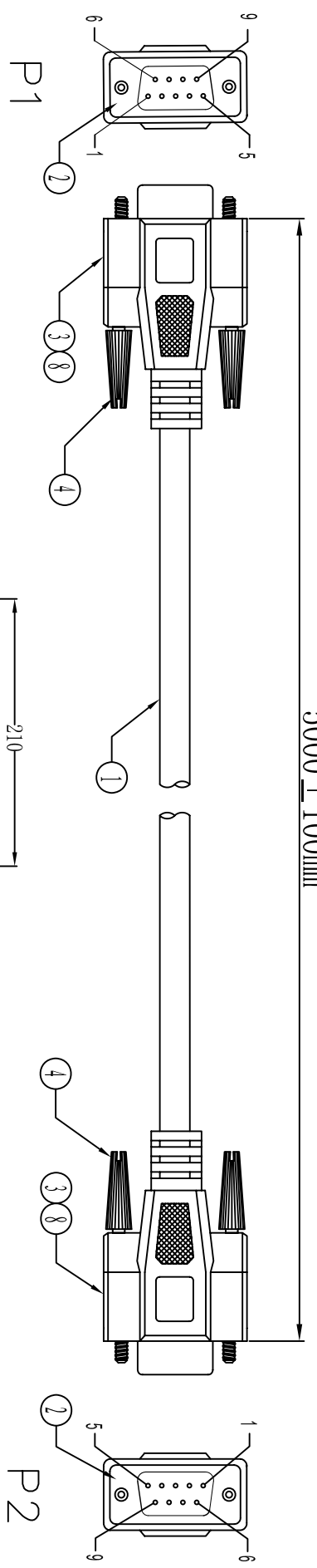

Electronic Test:  
 1. 100% Test,(Open,Short, Miss Wire)  
 2. Contact Resistance:2 ohm max.  
 3. Insulation Resistance:5M ohm min.  
 4. Hi-Pot:100V DC/10ms

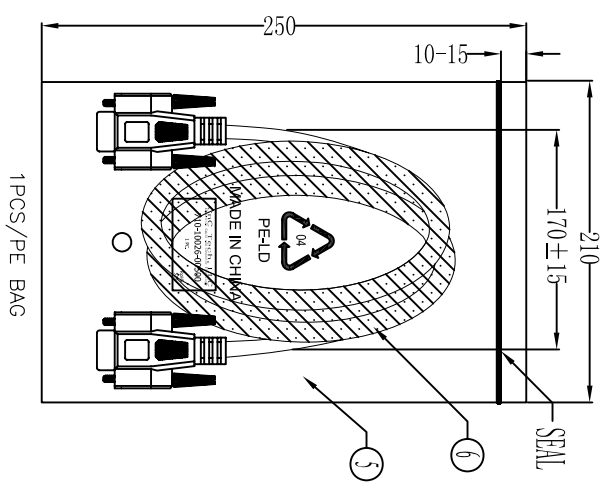

PIN ASSIGNMENT	
P1	P2
1 BLACK	1
2 GREY	2
3 YELLOW	3
4 PURPLE	4
5 ORANGE	5
6 RED	6
7 BROWN	7
8 GREEN	8
9 BLUE	9
SHELL D.W	SHELL

⑧	TUBE	2	HEAT SHRINK TUBE BLACK OD1.5*L15MM
⑦	PE BAG	1/5	CLEAR SIZE:330*380*0.05mm PRINT BLACK"MADE IN CHINA"+"5PCS" 及出货时间, 有透气孔.
⑥	PE FILM	1	PE FILM CLEAR W35*L30000mm.
⑤	PE BAG	1	CLEAR SIZE:210*290*0.05mm PRINT BLACK"MADE IN CHINA" 及出货时间, 有透气孔.
④	SCREW	4	SCREW:#4-40UNC L47mm,NICKEL PLATED,INSULATION COLOR BEIGE(V-29)
③	OUT JACKET	43.5g	BEIGE(V-29) 40P PVC(MOULD NO:WM-113)
②	IN JACKET	8g	CLEAR LDPE(MOULD NO:NM-049)
①	CABLE	1	DB 9PIN FEMALE PIN G/F SHELL-NICKEL SOLDER TYPE INSULATION COLOR BLUE NOUL 30AWG(7/0.10)*9C+D+W+AL/M+JACKET COROL:BEIGE(V-29) OD:5.0mm. L5000±20mm.

# CNC Tech, LLC

Industrial Cable and Connector Technology

DRAWN BY	ZHONGHGS	DRAWING NO.	
CHECKED BY		CUSTOMER	
APPROVAL BY		ITEM NO.	710-10026-00500
DECIDE BY		DATE	2012-02-06
VERSIONS/EDITION	A/0	PROJECTION	

