



Chipsmall Limited consists of a professional team with an average of over 10 year of expertise in the distribution of electronic components. Based in Hongkong, we have already established firm and mutual-benefit business relationships with customers from,Europe,America and south Asia,supplying obsolete and hard-to-find components to meet their specific needs.

With the principle of “Quality Parts,Customers Priority,Honest Operation,and Considerate Service”,our business mainly focus on the distribution of electronic components. Line cards we deal with include Microchip,ALPS,ROHM,Xilinx,Pulse,ON,Everlight and Freescale. Main products comprise IC,Modules,Potentiometer,IC Socket,Relay,Connector.Our parts cover such applications as commercial,industrial, and automotives areas.

We are looking forward to setting up business relationship with you and hope to provide you with the best service and solution. Let us make a better world for our industry!



Contact us

Tel: +86-755-8981 8866 Fax: +86-755-8427 6832

Email & Skype: info@chipsmall.com Web: www.chipsmall.com

Address: A1208, Overseas Decoration Building, #122 Zhenhua RD., Futian, Shenzhen, China



- NOTES:
- CARD SLOT ACCEPTS $.050 \pm .004$ (1.27 ± 0.10) MODULE THICKNESS. (MEASURED OVER P.C. PADS).
 - ALL PEGS ARE INTERFERENCE FITS TO PCB UNLESS NOTED ON THE DWG.
 - REFER TO PRODUCT SPEC PS-71243-9999 FOR PERFORMANCE SPECIFICATIONS.
 - PRODUCT IS PACKAGED IN TRAYS.
 - RECOMMENDED MODULE LAYOUT SHALL BE PER JEDEC MO-167.
 - RECOMMENDED PLATING ON MODULE PADS: 30 MICROINCH/(0.76 MICROMETER) MINIMUM HARD GOLD (Au) OVER 79 MICROINCH/(2.0 MICROMETER) MINIMUM NICKEL (Ni).
 - PRODUCT WILL HAVE DATE CODE STAMPED ON SIDE OF HOUSING.

MATERIALS:

HOUSING - GLASS FILLED LIQUID CRYSTAL POLYMER (LCP), UL 94V-0, COLOR: BLACK.

TERMINAL - PHOSPHOR BRONZE

LATCHES - GLASS FILLED HIGH TEMPERATURE NYLON, UL 94V-0. LATCH AT PIN #1 END IS IVORY COLOR. LATCH AT OPPOSITE END IS BLACK COLOR.

PLATING:

CONTACT AREA: GOLD (Au) FLASH; THICKNESS=2-10 MICROINCH/(0.05-0.25 MICROMETER), OVER PALLADIUM-NICKEL (Pd-Ni); THICKNESS=30 MICROINCH/(0.76 MICROMETER) MINIMUM.

SOLDER TAILS: TIN (Sn); THICKNESS=150 MICROINCH/(3.81 MICROMETER) MINIMUM.

UNDERPLATE: NICKEL (Ni) OVER ENTIRE CONTACT.

NOTE FOR LEAD FREE CONVERSION:

THE PRIMARY SHIPPING CARTON WILL BE LABELED "COMPLIANT TO ROHS DIRECTIVE 2002/95/EC AND ELV ANNEX II OF DIRECTIVE 2000/53/EC". CARTONS WITHOUT THIS LABEL MAY CONTAIN PRODUCT WITH LEAD.

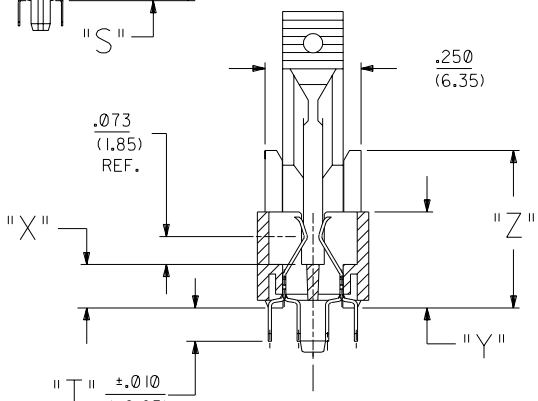
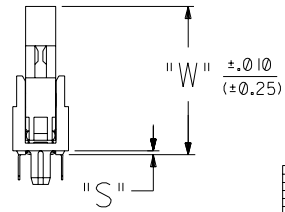
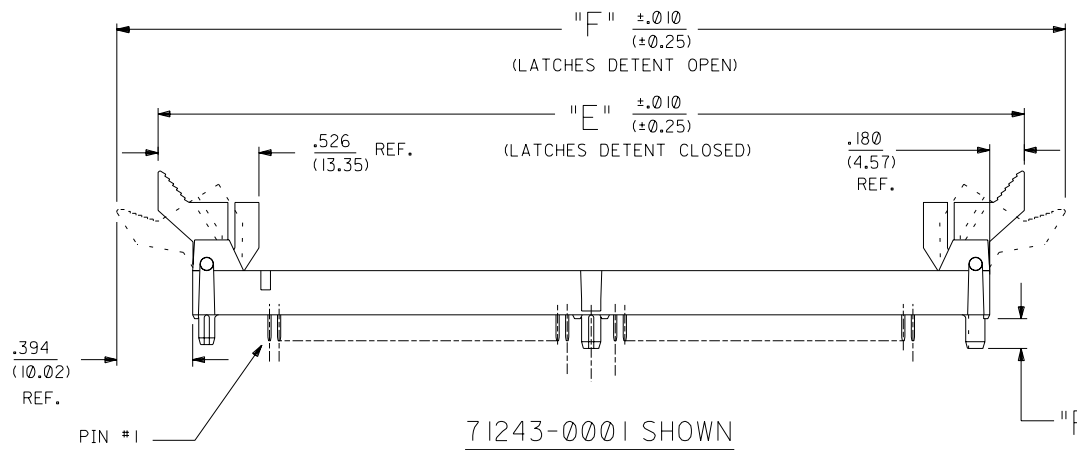
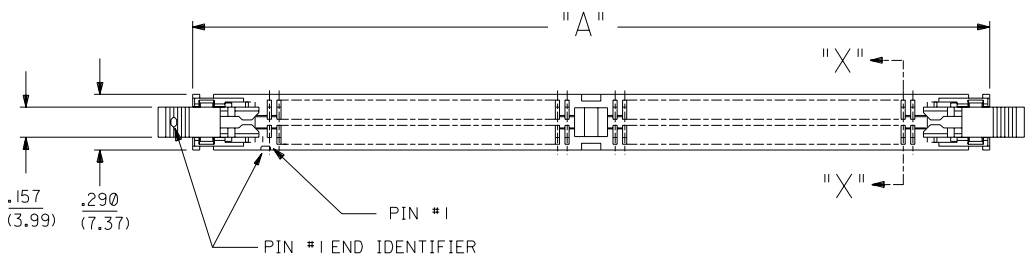

SECTION "X-X"
SCALE 4:1

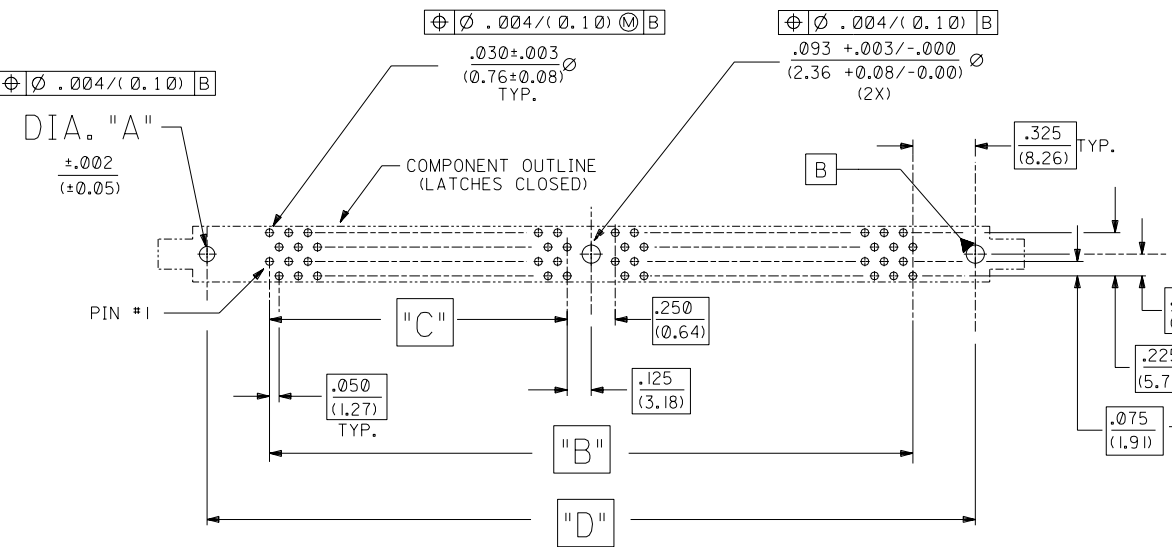

RECOMMENDED P.C. BOARD HOLE PATTERN (CONNECTOR SIDE)

71243									
GI	ADD LEAD FREE NOTE ECR#UDT2004-1732 DMORGAN 04/03/08								
G	OBSOLETE 136 CKT. ECR#UDT2000-0947 DMORGAN 00/03/23								
F	CHG Sn-Pb THICKNESS ECR#UDT1999-0454 DMORGAN 99/08/09								
E	REVISED PER ECR# U61133 96-10-1 LAURX								
D	REVISED PER ECR# U60883 3-18-96 JCL								
C	REVISED PER ECR# U60836 1-19-96 JCL								
B	REVISED PER ECR# U51288 8-4-95 JCL								
A	RMVD X REVISED PER ECR# U50617 12-27-94 JCL								
2	REVISED PER ECR# U50419 11-7-94 JCL								
1	RELEASED PER ECR# U40711 DCB 10/94								

MFG.	SH.	REV.	LTR.	REVISIONS

DIMENSIONS SHOWN (METRIC) INCH UNLESS OTHERWISE SPECIFIED TOLERANCES: ANGULAR ± 1/2°

3 PLACE	± .005	---
2 PLACE	± .01	± 0.13
1 PLACE	---	± 0.25

DRAFT WHERE APPLICABLE MUST REMAIN WITHIN DIMENSIONS

DRWG. BY: JCL CHK'D BY: DCB
 APP'D BY: SCALE: 2:1

FILE NAME: 57124301 DGN
 SHEET NO.: 1 OF 2
 DATE: 10/10/94
 U.S.A.

TITLE: $.050/(1.27)$ PITCH SINGLE LOW KEY DIMM SALES DRAWING

MOLEX INCORPORATED 60532 U.S.A.

PART NO.: SDA-71243-0

SEE CHART

THIS DRAWING CONTAINS INFORMATION THAT IS PROPRIETARY TO MOLEX INC. AND SHOULD NOT BE USED WITHOUT WRITTEN PERMISSION.

X = N.T.	ITEM NUMBER 71243	CIRCUIT SIZE	DIA. 'A'	DIM 'A'	DIM 'B'	DIM 'C'	DIM 'D'	DIM 'E'	DIM 'F'	DIM 'G'	DIM 'H'	DIM 'P'	DIM 'S'	DIM 'T'	DIM 'W'	DIM 'X'	DIM 'Y'	DIM 'Z'
	-0001	128	.062 (1.57)	4.150 (105.41)	3.350 (85.09)	1.550 (39.37)	4.000 (101.60)	4.510 (114.56)	4.938 (125.42)	3.850 (97.79)	3.584 (91.03)	.155 (3.94)	.020 (0.51)	.127 (3.23)	.772 (19.61)	.113 (2.87)	.250 (6.35)	.410 (10.41)
	-0002	144	.062 (1.57)	4.550 (115.57)	3.750 (95.25)	1.750 (44.45)	4.400 (111.76)	4.910 (124.71)	5.338 (135.58)	4.250 (107.95)	3.984 (101.19)	.155 (3.94)	.020 (0.51)	.127 (3.23)	.772 (19.61)	.113 (2.87)	.250 (6.35)	.410 (10.41)
	-0003	200	.062 (1.57)	5.950 (151.13)	5.150 (130.81)	2.450 (62.63)	5.800 (147.32)	6.310 (160.28)	6.738 (171.14)	5.650 (143.51)	5.384 (136.75)	.155 (3.94)	.020 (0.51)	.127 (3.23)	.772 (19.61)	.113 (2.87)	.250 (6.35)	.410 (10.41)
	-0004	SEE DRAWING NUMBER SDA-71243-0004																
	-0005	200	.080 (2.03)	5.950 (151.13)	5.150 (130.81)	2.450 (62.63)	5.800 (147.32)	6.310 (160.28)	6.738 (171.14)	5.650 (143.51)	5.384 (136.75)	.140 (3.55)	.035 (0.89)	.112 (2.84)	.787 (19.99)	.128 (3.25)	.265 (6.73)	.425 (10.79)
X	-0006	104	.062 (1.57)	3.550 (90.17)	2.750 (69.85)	1.250 (31.75)	3.400 (86.36)	3.910 (99.31)	4.338 (110.19)	3.250 (82.55)	2.984 (75.79)	.155 (3.94)	.020 (0.51)	.127 (3.23)	.772 (19.61)	.113 (2.87)	.250 (6.35)	.410 (10.41)
	-0008	160	.062 (1.57)	4.950 (125.73)	4.150 (105.41)	1.950 (49.53)	4.800 (121.92)	5.310 (134.88)	5.738 (145.74)	4.650 (118.11)	4.384 (111.35)	.155 (3.94)	.020 (0.51)	.127 (3.23)	.772 (19.61)	.113 (2.87)	.250 (6.35)	.410 (10.41)
	-0009	SEE DRAWING NUMBER SDA-71243-0009																

