



Chipsmall Limited consists of a professional team with an average of over 10 year of expertise in the distribution of electronic components. Based in Hongkong, we have already established firm and mutual-benefit business relationships with customers from,Europe,America and south Asia,supplying obsolete and hard-to-find components to meet their specific needs.

With the principle of “Quality Parts,Customers Priority,Honest Operation,and Considerate Service”,our business mainly focus on the distribution of electronic components. Line cards we deal with include Microchip,ALPS,ROHM,Xilinx,Pulse,ON,Everlight and Freescale. Main products comprise IC,Modules,Potentiometer,IC Socket,Relay,Connector.Our parts cover such applications as commercial,industrial, and automotives areas.

We are looking forward to setting up business relationship with you and hope to provide you with the best service and solution. Let us make a better world for our industry!



## Contact us

Tel: +86-755-8981 8866 Fax: +86-755-8427 6832

Email & Skype: info@chipsmall.com Web: www.chipsmall.com

Address: A1208, Overseas Decoration Building, #122 Zhenhua RD., Futian, Shenzhen, China



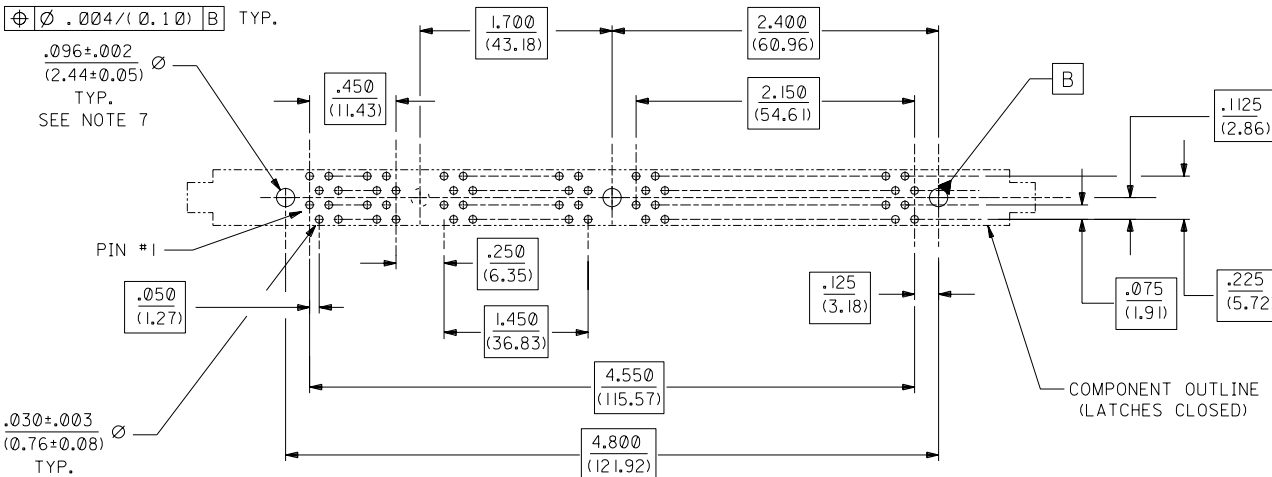
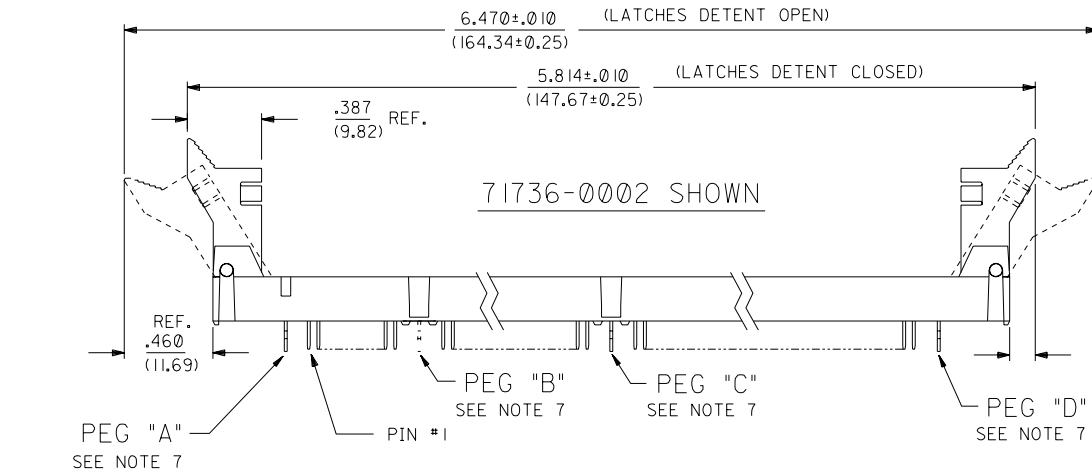
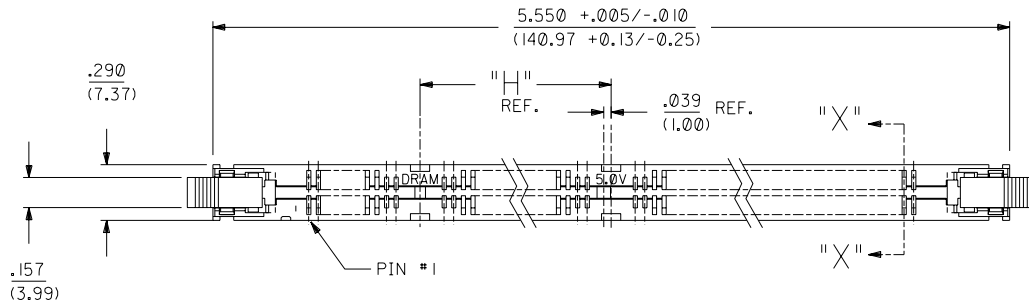

RECOMMENDED P.C. BOARD HOLE PATTERN (CONNECTOR SIDE)

- NOTES:
- CARD SLOT ACCEPTS .050±.004/(1.27±0.10) MODULE THICKNESS. (MEASURED OVER P.C. PADS).
  - RECOMMENDED PCB THICKNESS: .062±.007/(1.57±0.18)
  - REFER TO PRODUCT SPEC PS-71243-9999 FOR PERFORMANCE SPECIFICATIONS.
  - PRODUCT IS PACKAGED IN TRAYS.
  - RECOMMENDED MODULE LAYOUT SHALL BE PER JEDEC MO-161.
  - RECOMMENDED PLATING ON MODULE PADS: 30 MICROINCH/(0.76 MICROMETER) MINIMUM HARD GOLD (Au) OVER 79 MICROINCH/(2.0 MICROMETER) MINIMUM NICKEL (Ni).
  - SEE CHART FOR FORK/HOLE PRESENCE AND PLATING OPTION.
  - PRODUCT WILL HAVE DATE CODE STAMPED ON SIDE OF HOUSING.

MATERIALS:  
 HOUSING - GLASS FILLED LIQUID CRYSTAL POLYMER (LCP), UL 94V-0, COLOR: BLACK.  
 TERMINAL - PHOSPHOR BRONZE  
 LATCHES - GLASS FILLED HIGH TEMPERATURE NYLON, UL 94V-0, COLOR: IVORY.  
 FORKLLOCKS - STAINLESS STEEL

PLATING:  
 CONTACT AREA: OPTION A: GOLD (Au) FLASH; THICKNESS=2-10 MICROINCH/(0.05-0.25 (0.05-0.25 MICROMETER), OVER PALLADIUM-NICKEL (Pd-Ni); THICKNESS=30 MICROINCH/(0.76 MICROMETER) MINIMUM.  
 OPTION B: GOLD (Au) FLASH; THICKNESS=2-10 MICROINCH/(0.05-0.25 MICROMETER), OVER PALLADIUM-NICKEL (Pd-Ni); THICKNESS=20 MICROINCH/(0.51 MICROMETER) MINIMUM.

SOLDER TAILS: TIN (Sn); THICKNESS=150 MICROINCH/(3.81 MICROMETER) MINIMUM.  
 UNDERPLATE: NICKEL (Ni) OVER ENTIRE CONTACT.  
 FORKLLOCKS: NONE

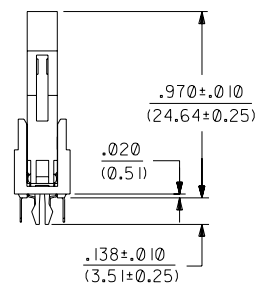

NOTE FOR LEAD FREE CONVERSION:  
 THE PRIMARY SHIPPING CARTON WILL BE LABELED "COMPLIANT TO ROHS DIRECTIVE 2002/95/EC AND ELV ANNEX II OF DIRECTIVE 2000/53/EC". CARTONS WITHOUT THIS LABEL MAY CONTAIN PRODUCT WITH LEAD.

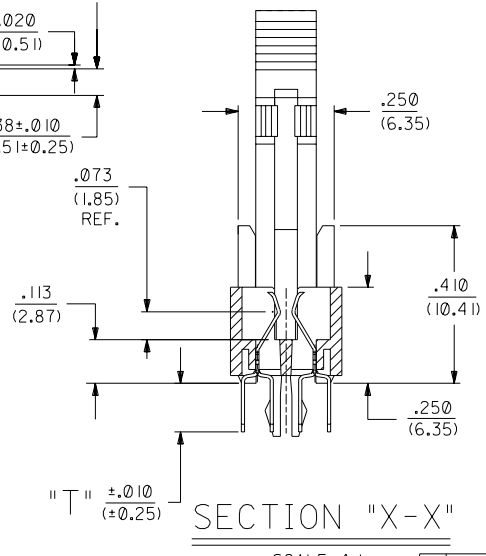

E1	ADD LEAD FREE NOTE ECN# UCP2004-1132 DMORGAN 04/03/09
E	CHG Sn-Pb THICKNESS ECN# UDI1999-0454 DMORGAN 99/08/09
D3	REVISED PER ECR# U71162 97-4-15 LAURX
D2	REVISED PER ECR# U70731 97-1-8 LAURX
D1	REVISED PER ECR# U70361 96-10-9 LAURX
D	REVISED PER ECR# U61133 96-9-26 LAURX
C	REVISED PER ECR# U61450 5-28-96 JCL
B	REVISED PER ECR# U61050 2-28-96 JCL
A	INITIAL RELEASE PER ECR# U60675 12-6-95 JCL

DIMENSIONS SHOWN (METRIC) INCH UNLESS OTHERWISE SPECIFIED TOLERANCES: ANGULAR ± 1/2°		REVISIONS	
3 PLAGE ± .005	---	3	D3
2 PLAGE ± ---	± 0.13	2	D3
1 PLAGE ---	± 0.25	1	E1
DRAFT WHERE APPLICABLE MUST REMAIN WITHIN DIMENSIONS		MFG, SH.	REV.
DRWG. NO. SDA-71736-0		LTR.	REV. 1
FILE NAME: ST173601.DGN		DATE: 12/06/95	
SCALE: 2:1		SHEET NO. 1 OF 3	
BY: JCL		DIV. CP	
APPR. BY: DCB		MFG. INC. AND SHOULD NOT BE USED WITHOUT WRITTEN PERMISSION	

X=N.T.	ITEM NO. 71736-0***	CKT SIZE	DESCRIPTION	COLOR	FUNCTION KEY	VOLTAGE KEY	PEG "A"	PEG "B"	PEG "C"	PEG "D"	DIM. 'H'	DIM. 'T'	CONTACT AREA PLATING
	-0001	168	3.3 VOLT STD DRAM	BLACK	CENTER	CENTER	FORK	NONE	FORK	FORK	1.700 (43.18)	.127 (3.23)	OPTION A
	-0002	168	5.0 VOLT STD DRAM	BLACK	CENTER	OFFSET LEFT	FORK	NONE	FORK	FORK	1.700 (43.18)	.127 (3.23)	OPTION A
	-0011	168	3.3 VOLT UNBUFFERED	BLACK	OFFSET RIGHT	CENTER	FORK	NONE	FORK	FORK	1.661 (42.19)	.127 (3.23)	OPTION A
	-0005	168	5.0 VOLT UNBUFFERED	BLACK	OFFSET RIGHT	OFFSET LEFT	FORK	NONE	FORK	FORK	1.661 (42.19)	.127 (3.23)	OPTION A
	-0006	168	3.3 VOLT SYNCHRONOUS	BLACK	OFFSET LEFT	CENTER	FORK	NONE	FORK	FORK	1.739 (44.17)	.127 (3.23)	OPTION A
	-0007	168	5.0 VOLT SYNCHRONOUS	BLACK	OFFSET LEFT	OFFSET LEFT	FORK	NONE	FORK	FORK	1.739 (44.17)	.127 (3.23)	OPTION A

- NOTES:
1. STRAIGHTNESS OF MODULE APPLIES TO THE AREA FROM THE BOTTOM OF THE CARD UP .157/(4.00).
  2. IF TIE BARS ARE ATTACHED TO PADS, THE TIE BAR SHOULD BE ON AN INTERNAL LAYER, SO THAT THE REMNANT CANNOT CAUSE DAMAGE TO THE CONTACTS.

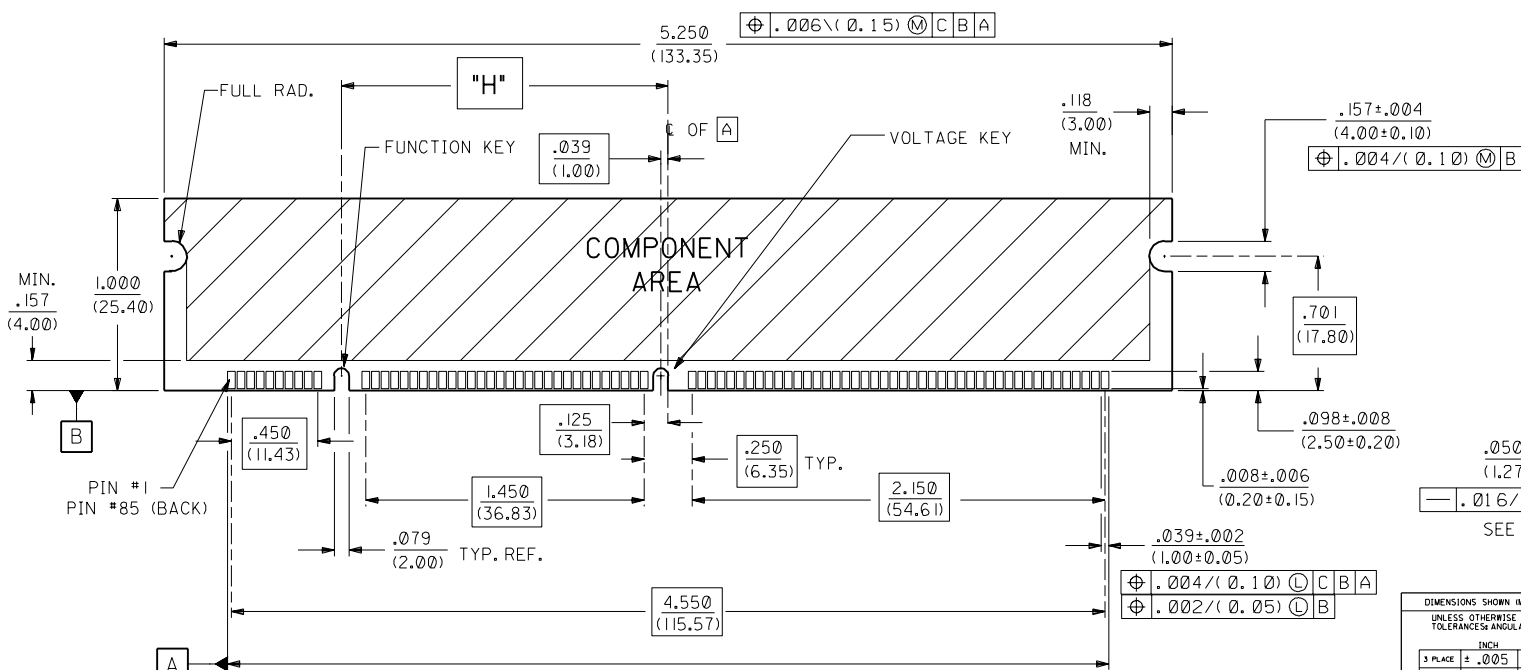
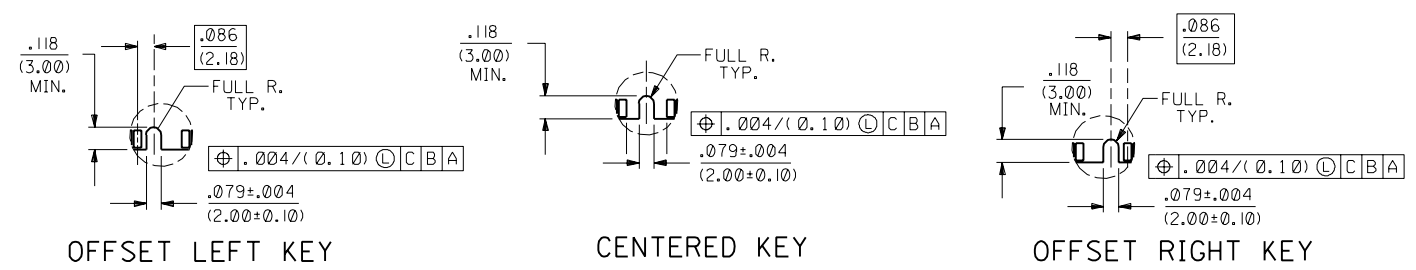

RECOMMENDED MODULE LAYOUT  
168 CKT 5.0V DRAM SHOWN

D3	SEE SHEET I
D2	SEE SHEET I
D1	SEE SHEET I
D	SEE SHEET I
C	SEE SHEET I
B	SEE SHEET I
A	SEE SHEET I

DIMENSIONS SHOWN (METRIC) INCH		UNLESS OTHERWISE SPECIFIED TOLERANCES ANGULAR ± 1/2°	
5 PLACE	± .005	INCH	METRIC
2 PLACE	± .01	± 0.13	
1 PLACE	---	± 0.25	

DRAFT WHERE APPLICABLE MUST REMAIN WITHIN DIMENSIONS

DRWG. NO.	FILE NAME	SHEET NO.	DATE
SDA-71736-0***	S7173602.DWG	2	12/06/95

SEE CHART

MFG. SH.	REV.	LTR.	REVISIONS

THIS DRAWING CONTAINS INFORMATION THAT IS PROPRIETARY TO MOLEX INC. AND SHOULD NOT BE USED WITHOUT WRITTEN PERMISSION.

71736