



Chipsmall Limited consists of a professional team with an average of over 10 year of expertise in the distribution of electronic components. Based in Hongkong, we have already established firm and mutual-benefit business relationships with customers from,Europe,America and south Asia,supplying obsolete and hard-to-find components to meet their specific needs.

With the principle of “Quality Parts,Customers Priority,Honest Operation,and Considerate Service”,our business mainly focus on the distribution of electronic components. Line cards we deal with include Microchip,ALPS,ROHM,Xilinx,Pulse,ON,Everlight and Freescale. Main products comprise IC,Modules,Potentiometer,IC Socket,Relay,Connector.Our parts cover such applications as commercial,industrial, and automotives areas.

We are looking forward to setting up business relationship with you and hope to provide you with the best service and solution. Let us make a better world for our industry!



Contact us

Tel: +86-755-8981 8866 Fax: +86-755-8427 6832

Email & Skype: info@chipsmall.com Web: www.chipsmall.com

Address: A1208, Overseas Decoration Building, #122 Zhenhua RD., Futian, Shenzhen, China



Accessories

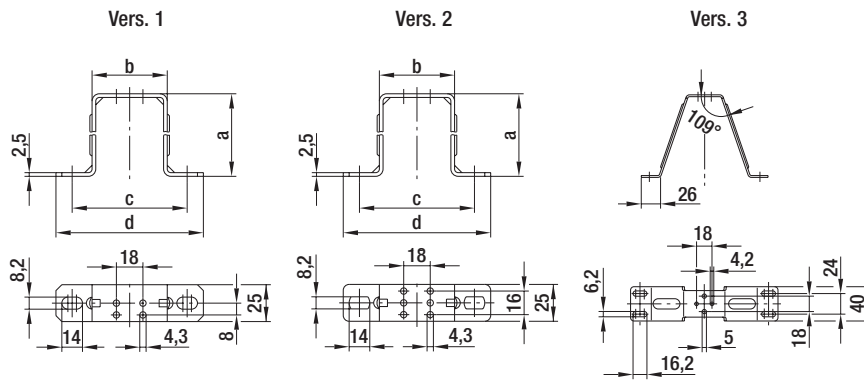

- **Material:** galvanised steel wire, chromatised in blue

ebm-papst • Mulfingen

Mounting brackets for Q-motors (foot measure 18 mm)

Part no.	Size	Vers.	a	b	c	d	Matching Q-motor
51025-2-4053	172	1	56,0	51	78	100	M4Q 045 -BD01-**
51028-2-4053	200	1	67,0	51	78	100	M4Q 045 -BD01-**, M4Q 045 -CA01-**
51026-2-4053	230	1	74,5	51	78	100	M4Q 045 -CA01-**, M4Q 045 -CA03-**
51027-2-4053	254	2	85,5	51	78	100	M4Q 045 -CA03-**, M4Q 045 -CF01-**, M4Q 045 -DA01-**
51014-2-4053	300	3	112,0	---	150	172	M4Q 045 -DA01-**, M4Q 045 -DA05-**, M4Q 045 -EA01-**, M4Q 045 -EF01-**

subject to alterations

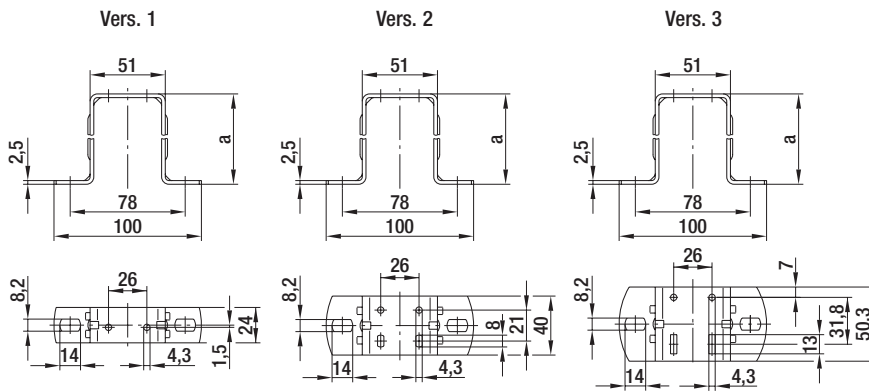

- **Material:** galvanised steel wire, chromatised in blue

ebm-papst • Mulfingen

Mounting brackets for Q-motors (foot measure 26 mm)

Part no.	Size	Vers.	a	Matching Q-motor
71881-2-4053	154	1	39	M4Q 045 -BD01-**
71882-2-4053	172	1	52	M4Q 045 -BD01-**
71883-2-4053	200 ⁽¹⁾ , 230 ⁽²⁾	1	72	M4Q 045 -BD01-**(1), M4Q 045 -CA01-**(1)(2), M4Q 045 -CA03-**(2)
71884-2-4053	254	1	84	M4Q 045 -CA03-**, M4Q 045 -CF01-**
71885-2-4053	254	2	84	M4Q 045 -DA01-**
71886-2-4053	300	2	109	M4Q 045 -DA01-**, M4Q 045 -DA05-**
71887-2-4053	300	3	109	M4Q 045 -EA01-**, M4Q 045 -EF01-**

subject to alterations

⁽¹⁾ size 200 fits M4Q045-BD01-** and M4Q045-CA01-**

⁽²⁾ size 230 fits M4Q045-CA01-** and M4Q045-CA03-**