



Chipsmall Limited consists of a professional team with an average of over 10 year of expertise in the distribution of electronic components. Based in Hongkong, we have already established firm and mutual-benefit business relationships with customers from,Europe,America and south Asia,supplying obsolete and hard-to-find components to meet their specific needs.

With the principle of "Quality Parts,Customers Priority,Honest Operation,and Considerate Service",our business mainly focus on the distribution of electronic components. Line cards we deal with include Microchip,ALPS,ROHM,Xilinx,Pulse,ON,Everlight and Freescale. Main products comprise IC,Modules,Potentiometer,IC Socket,Relay,Connector.Our parts cover such applications as commercial,industrial, and automotives areas.

We are looking forward to setting up business relationship with you and hope to provide you with the best service and solution. Let us make a better world for our industry!



Contact us

Tel: +86-755-8981 8866 Fax: +86-755-8427 6832

Email & Skype: info@chipsmall.com Web: www.chipsmall.com

Address: A1208, Overseas Decoration Building, #122 Zhenhua RD., Futian, Shenzhen, China



**DOUBLE ACTION HAND TOOL
720725-1**

1. The tool (see Fig.1) covered by this Instruction Sheet, crimps the applicable terminals listed in the table (Fig.2) below. These terminals can accept the stranded wires of the listed range. Use these terminals only, purchased as "Loose Piece Form" from TE connectivity. Read this Instruction Sheet carefully before you crimp terminals.

2. CRIMP SECTION:

This tool has two crimping sections.
To select proper crimping section:

- (a). Check your wire size and terminal numbers you are going to crimp, and see if they are applicable each other.
- (b). Match the crimp symbols in Fig.2 for the wire size you have chosen. These symbols must correspond with the markings stamped on the tool head. Mismatched application will result improper and unstable termination.

3. WIRE STRIPPING:

Strip the wire end in length shown in Fig. 2. Do not cut, nick or damage the strands when stripping.

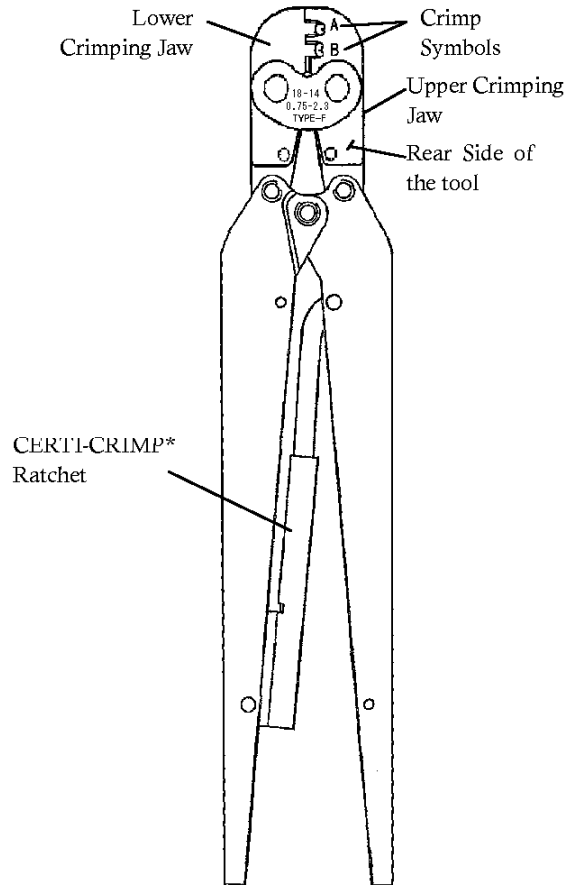

Fig.1

□ DO NOT USE STRIP TERMINAL

PART NUMBER	NEST SYMBOL	TERMINAL STRIP NO.	TERMINAL L.P. NO.	WIRE RANGE AWG [mm ²]	INSUL RANGE (mm)	STRIP LENGTH (mm)
720725-1	A	42100	42238	18 [0.75-0.85]	2.16-3.18	5.1-6.1
		170092	170108			
		42100	42238	16 [1.25-1.42]		
		170092	170108			
	B	170151	170153	14 [2.0-2.27]		
		42098	42241	18-16 [0.75-1.42]		
		42741	42806			
		170151	170153			
		42100	42238			
		170092	170108			

Fig.2

4. CRIMPING PROCEDURE:

- (a). This tool having CERTI-CRIMP* Ratchet can assure you constant and reliable wire crimping. To open handles, close them and squeeze until the ratchet releases. Note that once the ratchet is engaged, the handles can not be opened until they are fully closed.

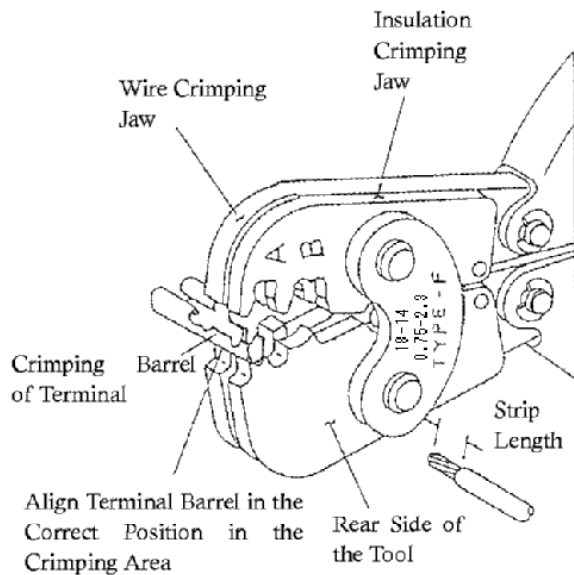

Fig.3

- (b). Insert the terminal into the crimping area as shown in Fig.3. Cautions must be taken care that the wire barrel and insulation barrel of the terminal area placed on the right position and direction in the area respectively.
- (c). Squeeze handles to close jaws to retain terminals.
- DO NOT DEFORM TERMINAL WIRE BARREL AND INSULATION BARREL.**
- (d). Insert stripped wire end into the barrels just enough to be located in the right position.
- (e). Hold wire in place and finish crimping by closing handles as far as they go, until CERTI-CRIMP Ratchet releases.
- (f). Open tool handles and remove the crimped terminal from the tool.

5. MAINTENANCE

Lubricate all pins, pivot points and bearing surfaces of the tool with motor oil of good quality. (SAE #20 or equivalent may be recommended.) Brush or wipe dirt off from the crimping surfaces and oil to prevent them from stains. Ask TE field engineers to calibrate handle pressure and crimp heights of the jaws after long period of use in order to maintain the tool in good condition for correct crimping.

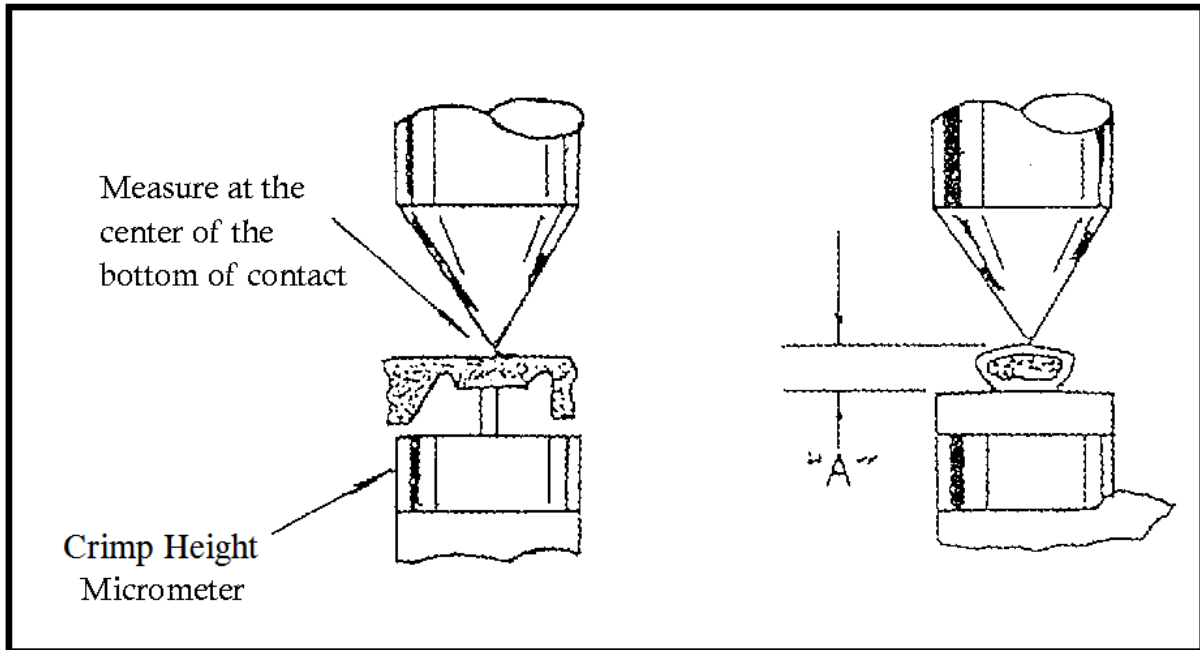

Fig.4

PART NUMBER	NEST SYMBOL	TERMINAL STRIP NO.	TERMINAL L.P. NO.	WIRE RANGE AWG [mm ²]	TERMINAL CRIMP HEIGHT (mm)
720725-1	A	42100	42238	18 [0.75-0.85]	1.12-1.28
		170092	170108		
		42100	42238	16 [1.25-1.42]	
		170092	170108		
	B	170151	170153	14 [2.0-2.27]	1.45-1.84
		42098	42241	18-16 [0.75-1.42]	
		42741	42806		
		170151	170153		
		42100	42238	14 [2.0-2.27]	
		170092	170108		

Fig.5