



Chipsmall Limited consists of a professional team with an average of over 10 year of expertise in the distribution of electronic components. Based in Hongkong, we have already established firm and mutual-benefit business relationships with customers from,Europe,America and south Asia,supplying obsolete and hard-to-find components to meet their specific needs.

With the principle of "Quality Parts,Customers Priority,Honest Operation,and Considerate Service",our business mainly focus on the distribution of electronic components. Line cards we deal with include Microchip,ALPS,ROHM,Xilinx,Pulse,ON,Everlight and Freescale. Main products comprise IC,Modules,Potentiometer,IC Socket,Relay,Connector.Our parts cover such applications as commercial,industrial, and automotives areas.

We are looking forward to setting up business relationship with you and hope to provide you with the best service and solution. Let us make a better world for our industry!



## Contact us

Tel: +86-755-8981 8866 Fax: +86-755-8427 6832

Email & Skype: info@chipsmall.com Web: www.chipsmall.com

Address: A1208, Overseas Decoration Building, #122 Zhenhua RD., Futian, Shenzhen, China



# Parallax Multi-Board Enclosure



## Styles

- # 721-32212 – Clear
- # 721-32214 – Opaque Red
- # 721-32216 – Transparent Blue
- # 721-32218 – Opaque Black

## Parts List

- (8) Acrylic sides
- (4) .25" F/M aluminum standoffs
- (4) 1.5" F/F aluminum standoffs
- (8) # 4-40 x .25" pan head screws
- (4) Rubber feet
- (1) # 4-40 nut

## Description

The Parallax Multi-Board Enclosure protects your circuits and provides an effective and robust way in which to display it. The enclosures come in four versions: Clear protects your circuitry and provides the highest visibility (you can see everything). Transparent Blue still allows you to see everything, yet gives your project that "understated elegance" look. Opaque Red and Opaque Black completely hide your projects, except for what you can see through the pre-cut access ports (power switch, power jack, and the programming connector). There are three interchangeable end panels. See below for information on which panel to use for the board you are using.

## Features

- Available in clear, opaque red, opaque black, or transparent blue
- Designed for the Propeller™ Proto Board, Super Carrier Board, and both the USB and Serial versions of the Board of Education®
- Laser cut 1/8" thick acrylic to protect and "show off" your projects
- Includes all required hardware for a complete package
- Pre-cut knockouts provide optional access to features on each of the boards
- Dimensions: 4.5 x 3.5 x 2.0 in (11.4 x 8.9 x 5.1 cm)

## Tools Required:

- Small Phillips screwdriver, not included

## Assembly

**Step 1:** Determine which end panel your board requires, and knock out any pre-cut areas as needed. To knock out an opening, gently press in the corner of each knock-out as indicated by the dots shown in Figure 1. You may wish to use a small file or sandpaper to smooth out any burrs.

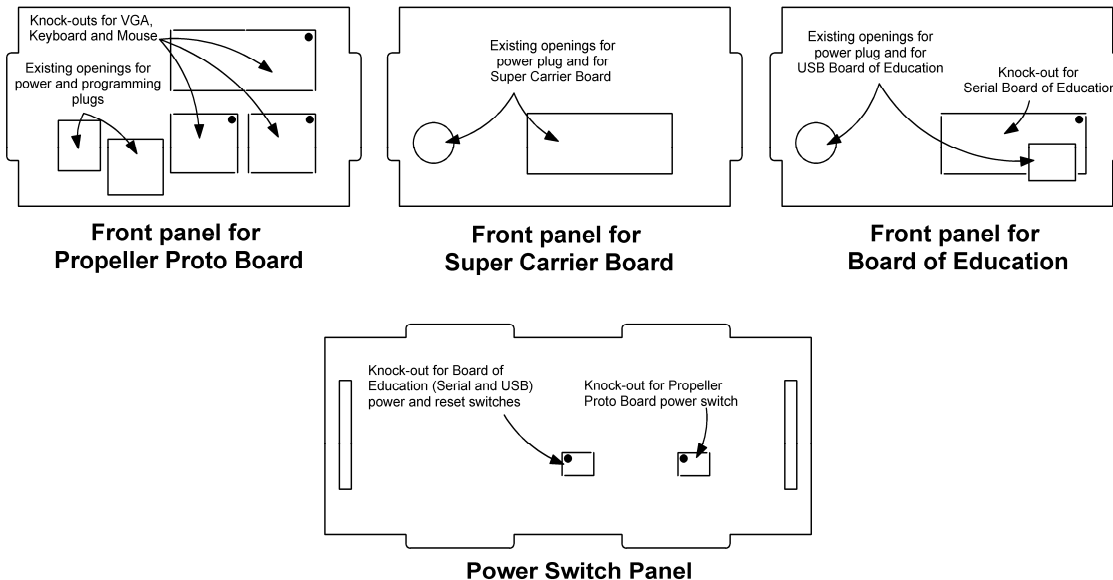
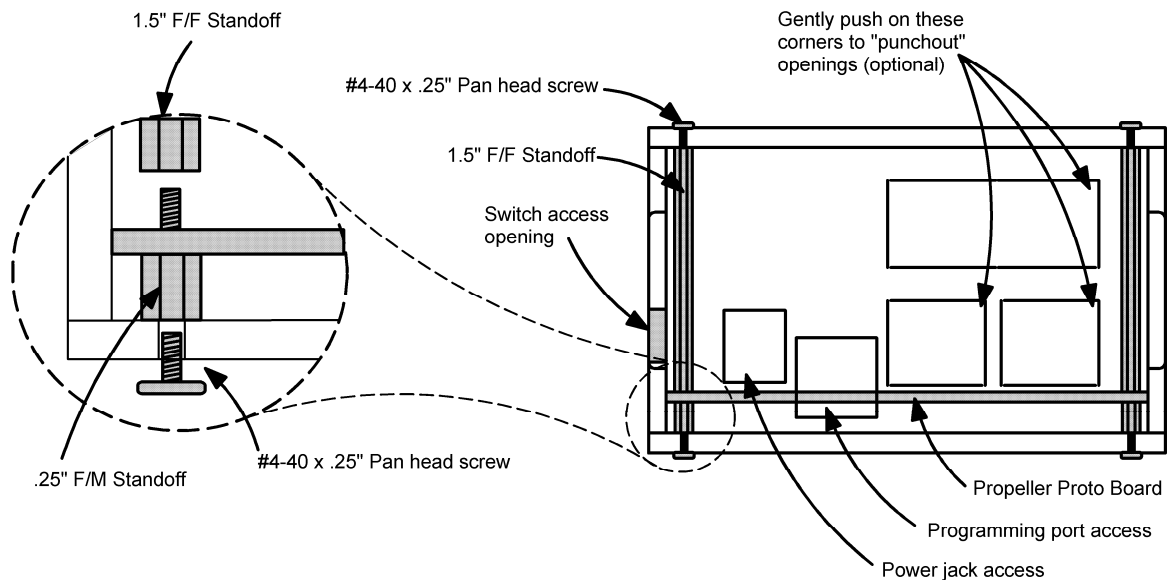

Figure 1

**Step 2:** Remove the protective paper from the acrylic pieces.

**Step 3:** If you're installing a Propeller Proto Board, attach the (4) .25" long F/M standoffs through each of the four corner mounting holes with a corresponding 1.5" long F/F standoff, as shown in Figure 2. Make them snug, but do not over-tighten. If you're installing any of the other boards, do not install the 1.5" long F/F that is nearest the power jack—it interferes with the power plug, and is not used.



**Figure 2**

**Step 4:** Place the assembly face down (on the 1.5" standoffs), with the bottom of the Propeller Proto Board up.

**Step 5:** Mount one of the large acrylic plates (there are two, and they're identical) onto the short standoffs and attach with (4) # 4-40 pan head screws. Do not tighten yet. If you're installing a Board of Education or Super Carrier Board, be sure to install the F/M standoff on the acrylic plate with a # 4-40 pan head screw, and then attach the board to the standoff using a # 4-40 nut.

**Step 6:** Flip the assembly right-side up and insert the four sides in their appropriate places. Be sure to orient the sides so that the access holes for the board's power plug, programming port, and power switch are positioned correctly; see Figure 3.

**Step 7:** Place the remaining acrylic panel on top of the assembly, and attach it with the (4) remaining # 4-40 pan head screws. If you're installing a Board of Education or Super Carrier Board, you can use a # 4-40 pan head screw and # 4-40 nut to close the hole, if you so desire.

**Step 8:** Tighten all (8) pan head screws.

**Step 9:** Attach the (4) rubber feet to the bottom, and now you can show off your project!

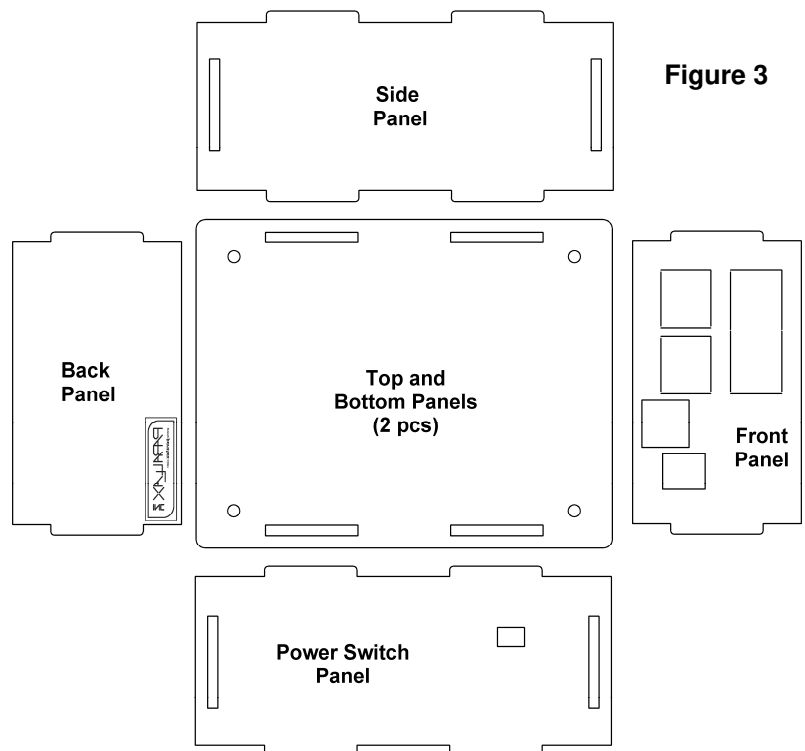

**Figure 3**