



Chipsmall Limited consists of a professional team with an average of over 10 year of expertise in the distribution of electronic components. Based in Hongkong, we have already established firm and mutual-benefit business relationships with customers from,Europe,America and south Asia,supplying obsolete and hard-to-find components to meet their specific needs.

With the principle of “Quality Parts,Customers Priority,Honest Operation,and Considerate Service”,our business mainly focus on the distribution of electronic components. Line cards we deal with include Microchip,ALPS,ROHM,Xilinx,Pulse,ON,Everlight and Freescale. Main products comprise IC,Modules,Potentiometer,IC Socket,Relay,Connector.Our parts cover such applications as commercial,industrial, and automotives areas.

We are looking forward to setting up business relationship with you and hope to provide you with the best service and solution. Let us make a better world for our industry!



Contact us

Tel: +86-755-8981 8866 Fax: +86-755-8427 6832

Email & Skype: info@chipsmall.com Web: www.chipsmall.com

Address: A1208, Overseas Decoration Building, #122 Zhenhua RD., Futian, Shenzhen, China



Model 73044
N Type "T" Jack-Plug-Jack Adapter

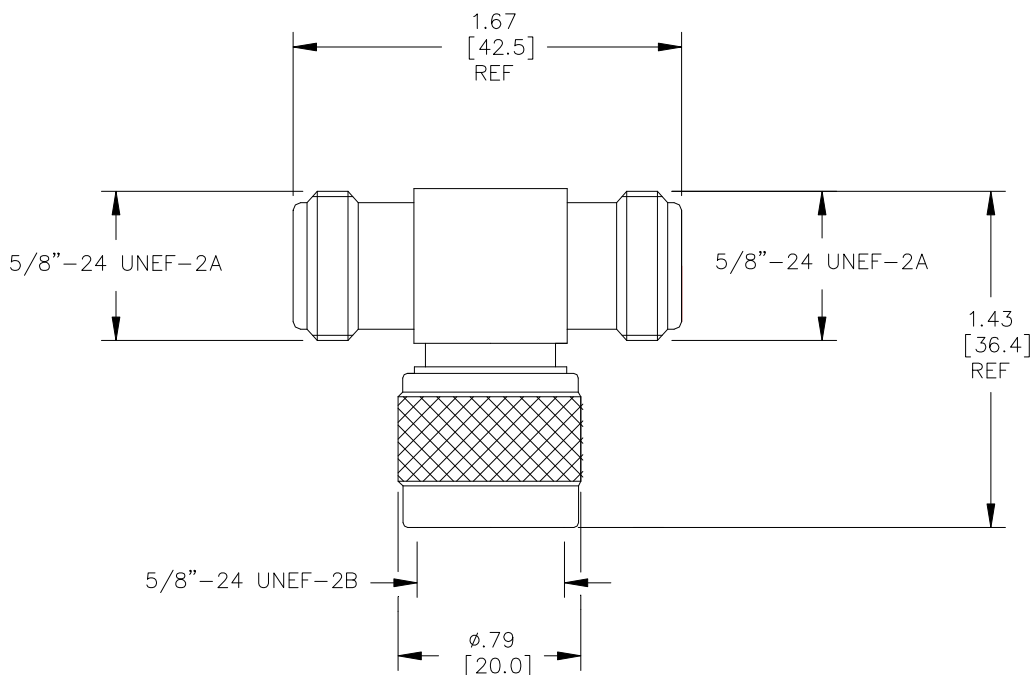

Model 73044
N Type "T" Jack-Plug-Jack Adapter

Features

- DC – 4GHz bandwidth.
- Connectors are precision machined.
- Meets interface requirements MIL-C-39012.

Materials

Center Conductor:
Male: Brass, Gold Plated
Female: Phosphor Bronze, Gold Plated
 Connector Body: Brass, Nickel Plated
 Insulators: PTFE

Specifications

Impedance: 50Ω
 Frequency Range: DC – 4GHz
 Contact Resistance:
 Center Conductor: ≤1.0 mΩ
 Outer Conductor: ≤0.2 mΩ
 Insulation Resistance: ≥ 5000 MΩ
 Dielectric Withstand Voltage: 1500V
For CE compliance, do not hold in hand when voltages exceed 33 Vrms / 70 Vdc.
 Number of Insertions: 500 cycles minimum

Ordering Information

Model: **73044**

USA: Sales: 800-490-2361
 Technical Support: technicalsupport@pomonatest.com
 Fax: 425-446-5844

Europe: 31-(0) 40 2675 150 **International:** 425-446-5500
Where to Buy: www.pomonaelectronics.com

All dimensions are in inches. Tolerances (except noted): .xx = ±.02" (.51 mm), .xxx = ±.005" (.127 mm). All specifications are to the latest revisions. Specifications are subject to change without notice. Registered trademarks are the property of their respective companies.