



Chipsmall Limited consists of a professional team with an average of over 10 year of expertise in the distribution of electronic components. Based in Hongkong, we have already established firm and mutual-benefit business relationships with customers from,Europe,America and south Asia,supplying obsolete and hard-to-find components to meet their specific needs.

With the principle of “Quality Parts,Customers Priority,Honest Operation,and Considerate Service”,our business mainly focus on the distribution of electronic components. Line cards we deal with include Microchip,ALPS,ROHM,Xilinx,Pulse,ON,Everlight and Freescale. Main products comprise IC,Modules,Potentiometer,IC Socket,Relay,Connector.Our parts cover such applications as commercial,industrial, and automotives areas.

We are looking forward to setting up business relationship with you and hope to provide you with the best service and solution. Let us make a better world for our industry!



## Contact us

Tel: +86-755-8981 8866 Fax: +86-755-8427 6832

Email & Skype: info@chipsmall.com Web: www.chipsmall.com

Address: A1208, Overseas Decoration Building, #122 Zhenhua RD., Futian, Shenzhen, China



**Model 73047**  
**N Type Jack to UHF Plug Adapter**

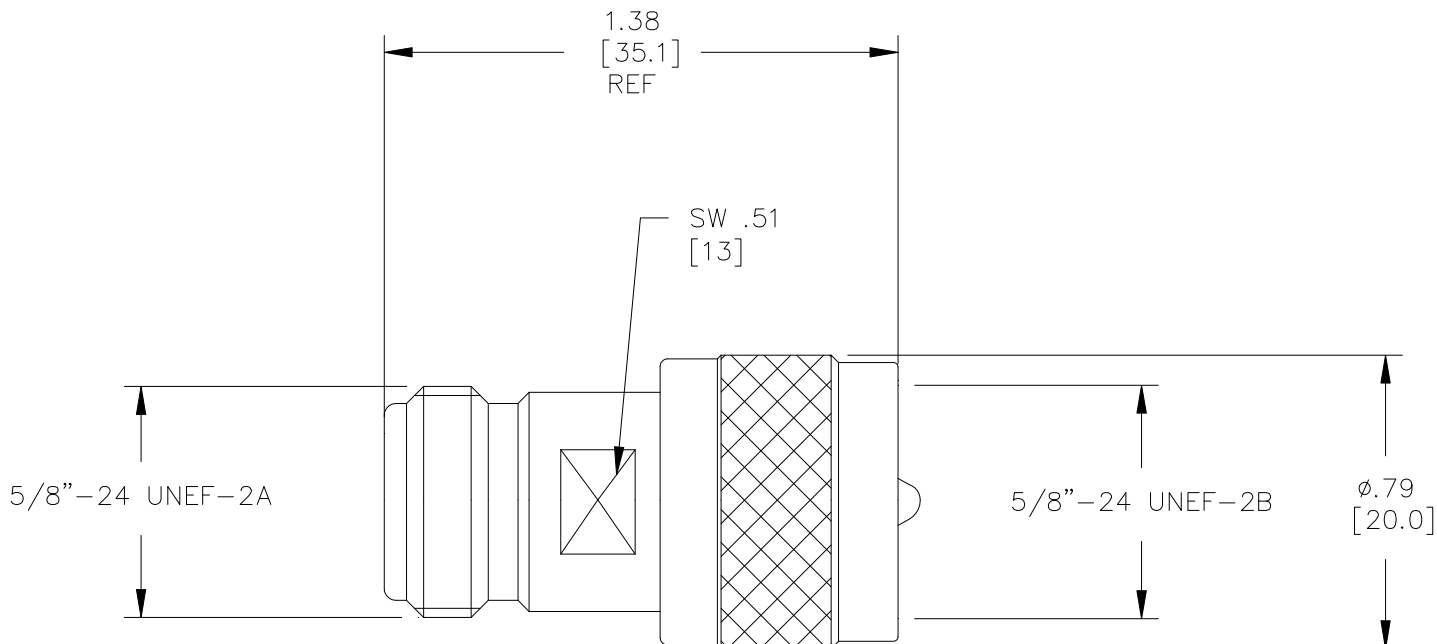

*Model 73047*  
*N Type Jack to UHF Plug Adapter*

**Features**

- DC – 300MHz bandwidth.
- Connectors are precision machined.

**Materials**

Center Conductor: Phosphor Bronze, Gold Plated  
Connector Body: Brass, Nickel Plated  
Insulators: PTFE

**Specifications**

|                               |  |
|-------------------------------|--|
| Frequency Range:              | DC – 300MHz  |
| Contact Resistance:           |  |
| Center Conductor:             | ≤1.0 mΩ  |
| Outer Conductor:              | ≤0.2 mΩ  |
| Insulation Resistance:        | ≥ 300 MΩ   |
| Dielectric Withstand Voltage: | 750V   |
|                               | <i>For CE compliance, do not hold in hand when voltages exceed 33 Vrms / 70 Vdc.</i> |
| Number of Insertions:         | 500 cycles minimum   |

**Ordering Information**

Model: **73047**

**USA:** Sales: 800-490-2361  
Technical Support: [technicalsupport@pomonatest.com](mailto:technicalsupport@pomonatest.com)  
Fax: 425-446-5844

**Europe:** 31-(0) 40 2675 150 **International:** 425-446-5500

**Where to Buy:** [www.pomonaelectronics.com](http://www.pomonaelectronics.com)

All dimensions are in inches. Tolerances (except noted): .xx = ±.02" (.51 mm), .xxx = ± .005" (.127 mm). All specifications are to the latest revisions. Specifications are subject to change without notice. Registered trademarks are the property of their respective companies.