



Chipsmall Limited consists of a professional team with an average of over 10 year of expertise in the distribution of electronic components. Based in Hongkong, we have already established firm and mutual-benefit business relationships with customers from,Europe,America and south Asia,supplying obsolete and hard-to-find components to meet their specific needs.

With the principle of “Quality Parts,Customers Priority,Honest Operation,and Considerate Service”,our business mainly focus on the distribution of electronic components. Line cards we deal with include Microchip,ALPS,ROHM,Xilinx,Pulse,ON,Everlight and Freescale. Main products comprise IC,Modules,Potentiometer,IC Socket,Relay,Connector.Our parts cover such applications as commercial,industrial, and automotives areas.

We are looking forward to setting up business relationship with you and hope to provide you with the best service and solution. Let us make a better world for our industry!



Contact us

Tel: +86-755-8981 8866 Fax: +86-755-8427 6832

Email & Skype: info@chipsmall.com Web: www.chipsmall.com

Address: A1208, Overseas Decoration Building, #122 Zhenhua RD., Futian, Shenzhen, China



PRODUCT NUMBER
SEE SHEET 1

LTR	PART NAME	QTY
1	PRODUCT	280
2	TAPE	1
3	REEL	1
4	COVER TAPE	1

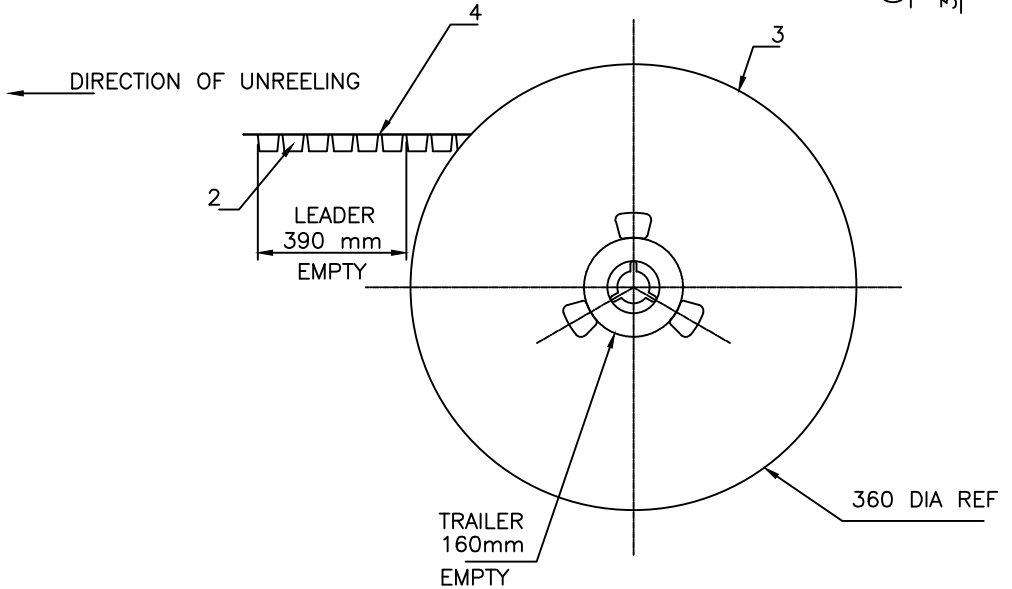
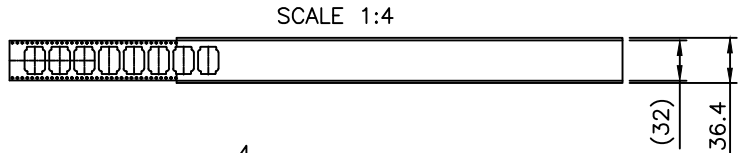
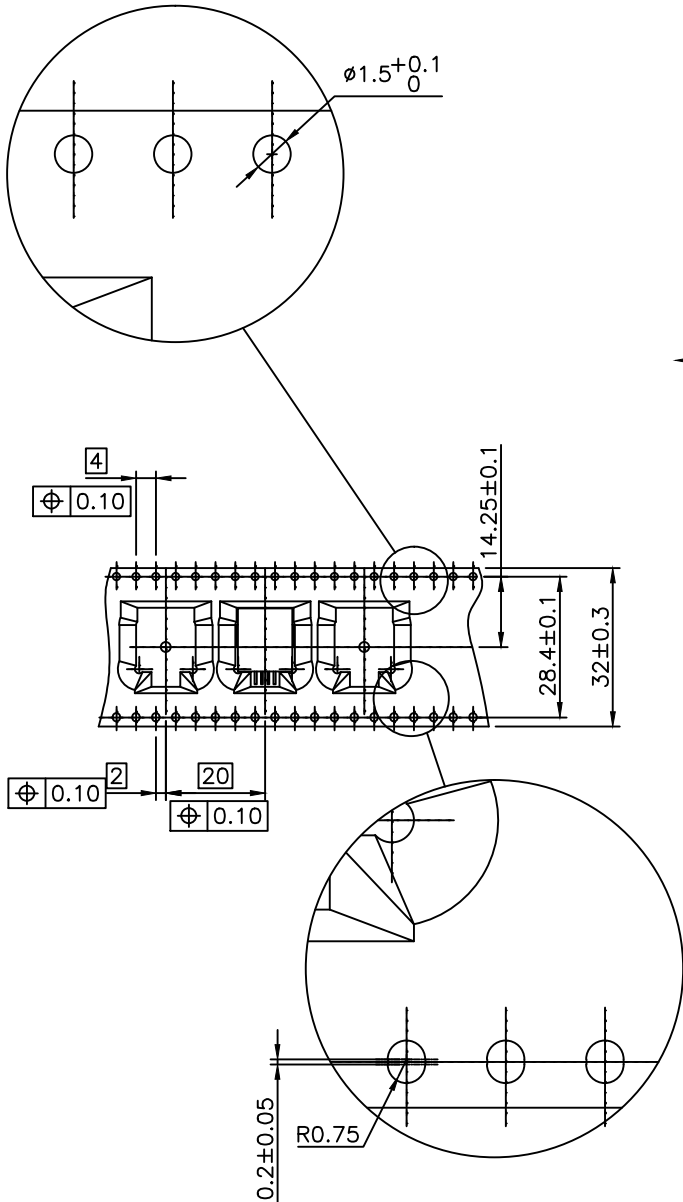

1- IN ACCORDANCE WITH EIA-481 AND IEC 296-3

CUSTOMER COPY FOR REFERENCE ONLY

mat'l. code	surface ISO 1302 ✓	tolerance ISO 406 ISO 1101	projection mm	product family MOD-JACK
ltr	ecn no	dr	date	title
E	F90120	DLE	99.02.01	SMT RA JACK
F	F06.0240	DLE	06.07.18	4 POS. NARROW OUTSIDE
tolerances unless otherwise specified angles linear				scale 1:1
dr	D LEGRAND	06.07.18		
enr	P NIZZI	06.07.18		
chr	D LEGRAND	06.07.18		
appd	P NIZZI	06.07.18		
sheet index	revision sheet	dwg no 73306 sheet 2 of 3 size A3 type CUSTOMER Drawing		

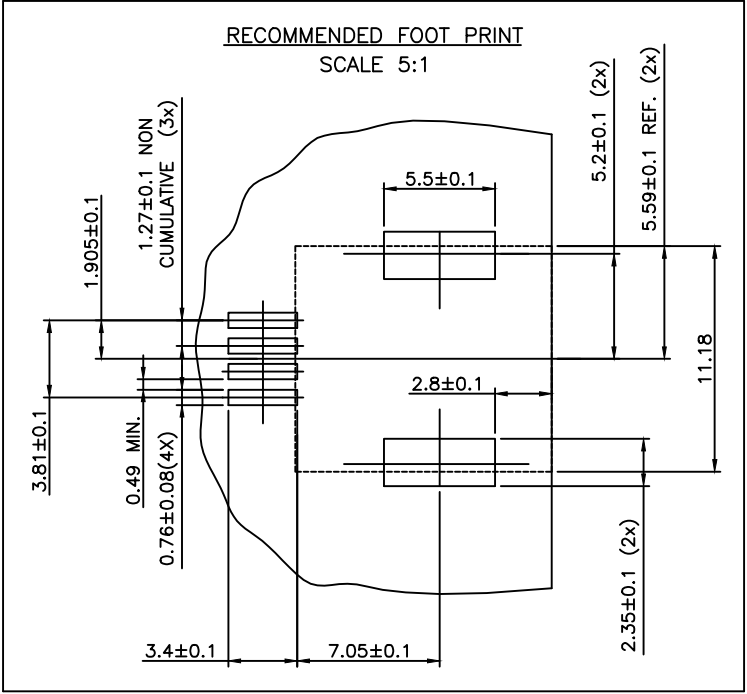

FCconnect.com

CUSTOMER COPY FOR REFERENCE ONLY

mat'l. code		surface	tolerance	projection	product family		
		ISO 1302 <input checked="" type="checkbox"/>	ISO 406 ISO 1101		MOD JACK		
ltr	ecn no	dr	date	tolerances unless otherwise specified		title	
A	F04.0363	DLE	04.10.18	angles	±0.13	SMT RA JACK 4 POS NARROW OUTSIDE	
B	F06-0240	DLE	06.07.18	linear	mm		
				±2°	scale 2:1		
dr	D LEGRAND		04.10.18			dwg no	
engr	P NIZZI		04.10.18			sheet 3 of - size	
chr	D LEGRAND		04.10.18			73306	A4
appd	P NZ		04.10.18			type	CUSTOMER Drawing
sheet index	revision sheet						

form: A4