



Chipsmall Limited consists of a professional team with an average of over 10 year of expertise in the distribution of electronic components. Based in Hongkong, we have already established firm and mutual-benefit business relationships with customers from,Europe,America and south Asia,supplying obsolete and hard-to-find components to meet their specific needs.

With the principle of “Quality Parts,Customers Priority,Honest Operation,and Considerate Service”,our business mainly focus on the distribution of electronic components. Line cards we deal with include Microchip,ALPS,ROHM,Xilinx,Pulse,ON,Everlight and Freescale. Main products comprise IC,Modules,Potentiometer,IC Socket,Relay,Connector.Our parts cover such applications as commercial,industrial, and automotives areas.

We are looking forward to setting up business relationship with you and hope to provide you with the best service and solution. Let us make a better world for our industry!



Contact us

Tel: +86-755-8981 8866 Fax: +86-755-8427 6832

Email & Skype: info@chipsmall.com Web: www.chipsmall.com

Address: A1208, Overseas Decoration Building, #122 Zhenhua RD., Futian, Shenzhen, China



LOC AI	DIST 00	REVISIONS				
P	LTR	DESCRIPTION	DATE	DWN	APVD	
B		ECR-16-009610	04 JUL16	LS	GS	

STRIP TOOL, AWG 28-10



Für Querschnitte /
For cross section
0.08mm² - 6.0mm² / AWG 28 - 10



Abmessungen / Dimension
Länge/Length: 193 mm
Breite/Width: 103 mm
Tiefe/Depth: 17 mm

Bedienungsanleitung /
Operating instructions
408-8907

THIS DRAWING IS UNPUBLISHED. © COPYRIGHT - BY TYCO ELECTRONICS CORPORATION. ALL INTERNATIONAL RIGHTS RESERVED. RELEASED FOR PUBLICATION

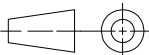
DIMENSIONS: mm	DWN L.Sandhu	06DEC2010	MATERIAL	FINISH	
	CHK L.Sandhu	06DEC2010	 TE Connectivity		
TOLERANCES UNLESS OTHERWISE SPECIFIED:	APVD L.Sandhu	06DEC2010			
0 PLC ± -	PRODUCT SPEC		SIZE	CAGE CODE	DRAWING NO
1 PLC ± -	APPLICATION SPEC		A4	00779	734185-1
2 PLC ± -	WEIGHT	0,191kg	RESTRICTED TO		—
3 PLC ± -		CUSTOMER DRAWING	SCALE	SHEET	1 OF 1
4 PLC ± -					REV
ANGLES ± -					