



Chipsmall Limited consists of a professional team with an average of over 10 year of expertise in the distribution of electronic components. Based in Hongkong, we have already established firm and mutual-benefit business relationships with customers from,Europe,America and south Asia,supplying obsolete and hard-to-find components to meet their specific needs.

With the principle of “Quality Parts,Customers Priority,Honest Operation,and Considerate Service”,our business mainly focus on the distribution of electronic components. Line cards we deal with include Microchip,ALPS,ROHM,Xilinx,Pulse,ON,Everlight and Freescale. Main products comprise IC,Modules,Potentiometer,IC Socket,Relay,Connector.Our parts cover such applications as commercial,industrial, and automotives areas.

We are looking forward to setting up business relationship with you and hope to provide you with the best service and solution. Let us make a better world for our industry!



Contact us

Tel: +86-755-8981 8866 Fax: +86-755-8427 6832

Email & Skype: info@chipsmall.com Web: www.chipsmall.com

Address: A1208, Overseas Decoration Building, #122 Zhenhua RD., Futian, Shenzhen, China



Smart Box (part no. 74-00003.1)

Technical specifications

Description

Housing construction kit with holes for two EAO Series 84 pushbuttons and separate M12 plug. Housing protection when assembled with specified switches and M12 plug together is compliant with IP67.

Shipped:

- Empty Smart Box in unassembled condition
- plug is not included in shipment
- S84 pushbutton components are not included in shipment

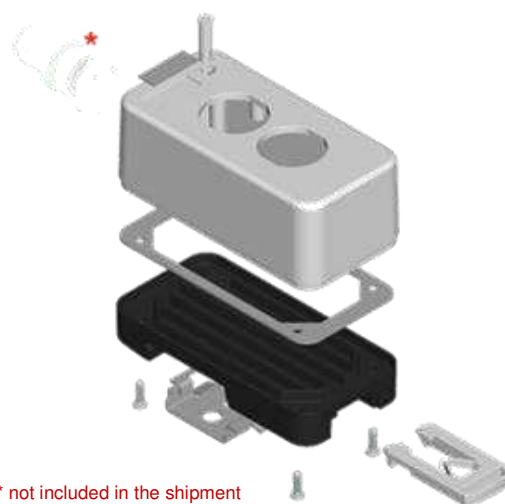

* not included in the shipment

Items / materials included in shipment:

Materials

Upper part of housing:	PBT / UL-V0 / colour similar to RAL9010
Lower part of housing:	PBT / UL-V0 / colour similar to RAL9011
Spring element (for restraint):	POM (nature)
Seal:	MVQ silicone foam bright
Light pipe:	PC / glass clear
Mounting adaptor:	Stainless steel 1.4301 / surface vibratory finish
Housing screws:	Stainless steel A2
Marking plate:	Black PVC / surface aluminium-coloured, adhesive

Drilling patterns:

EAO Series 84 button: Actuator part no. 84-2101.0 and similar

Hole for M12 plug:

Installation optimised for plugs from Murr Elektronik
Basic version: Type 17162

Operating conditions

Temperature range:

Operating temperature: -25 ... 60°C
Storage temperature: -40 ... 85°C

Standards:

Degree of protection: IP67 (in screwed condition / with mounted pushbuttons and female connector)

Mechanical characteristics

Housing dimensions:

Assembly / mounting dimensions:

See dimensional diagram 2
(Female M12 connector not included)

Please note:

- The dimensional diagrams show the housing with the Series 84 components and M12 plug fitted (not included in shipment)
- All side walls exhibit a pull of around 1°.

Certificates

CE

Created:	Reviewed:	Approved:	Doc. No.	Version / status	Page
28/09/2017 / KRJ	28/09/2017 / KRJ	28/09/2017 / KRJ	19003064099	C / 2590 Series - released	1/3
EAO Systems AG	CH-4600 Olten	Telephone +41 62 286 91 11		Fax +41 62 296 21 62	www.eao.com

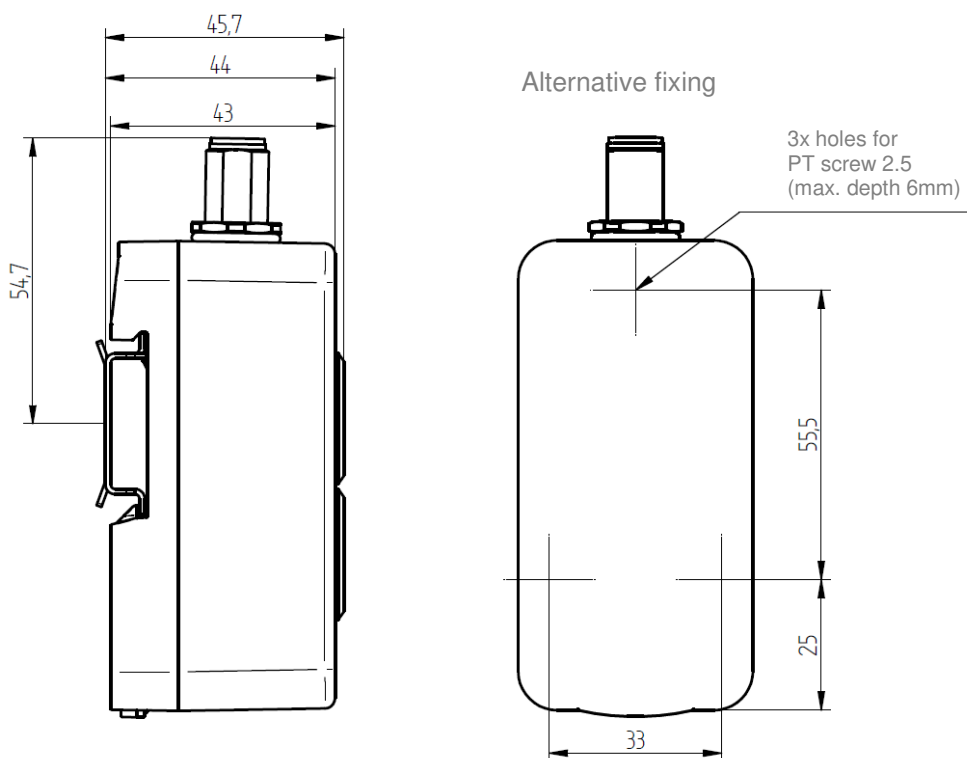
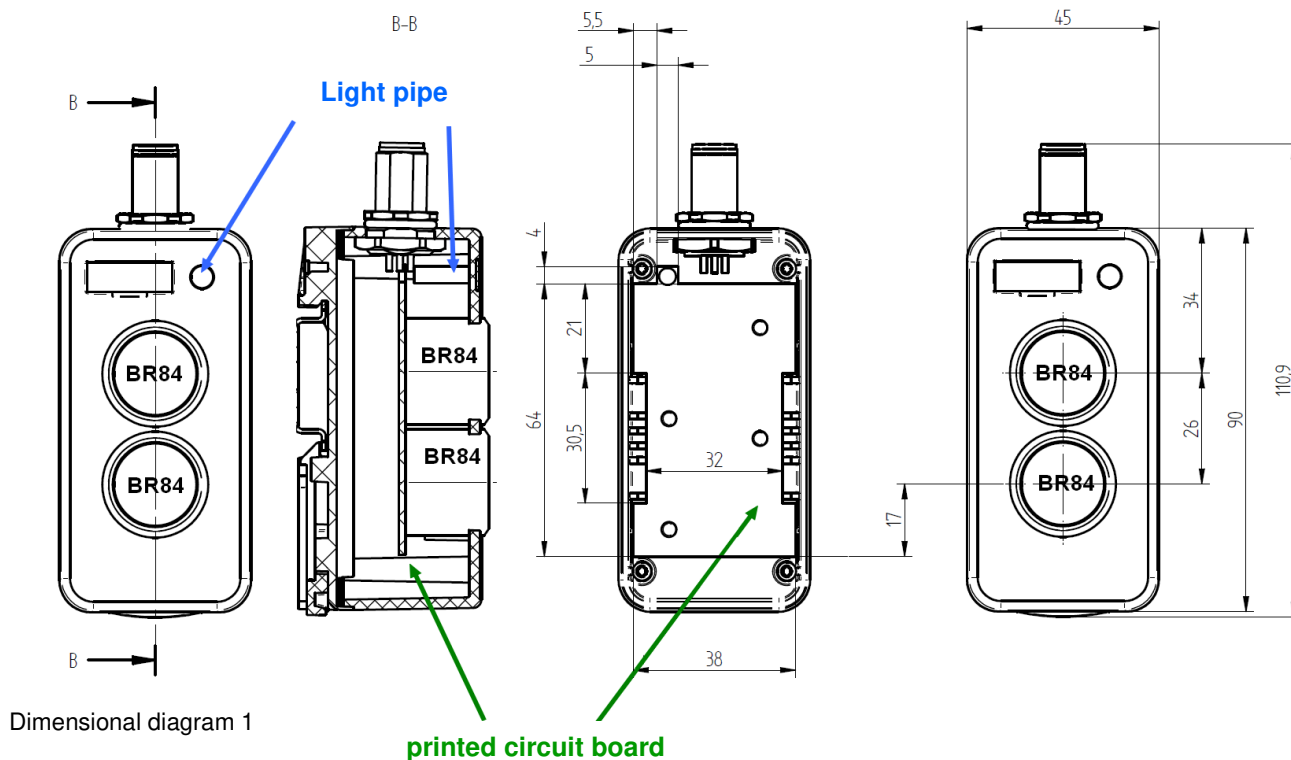

Mounting

- Mount mounting adapter onto mounting surface.
- Mount Smart Box on one side (note direction of mounting adapter on the housing)
- Push the Smart Box onto the adaptor on the other side until it audibly clicks into place
- Alternatively, the module can be mounted on a standard top hat rail, or it can be mounted on a base using screws on the rear (see dimensional diagrams).

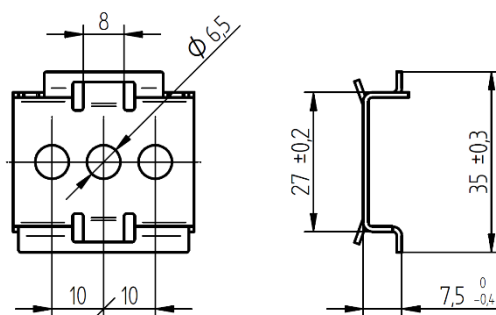

Dismantling

- Pull out spring element using screwdriver and lift Smart Box
- Remove Smart Box from the other side

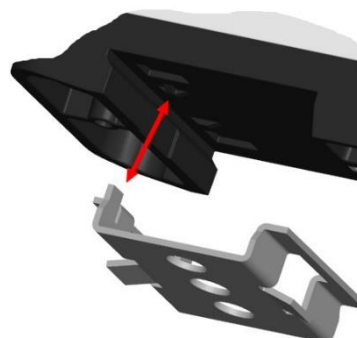

EAO reference number: **Part no. 74-00003.1**

EAO reserves the right to change specifications without further notice.