



Chipsmall Limited consists of a professional team with an average of over 10 year of expertise in the distribution of electronic components. Based in Hongkong, we have already established firm and mutual-benefit business relationships with customers from,Europe,America and south Asia,supplying obsolete and hard-to-find components to meet their specific needs.

With the principle of “Quality Parts,Customers Priority,Honest Operation,and Considerate Service”,our business mainly focus on the distribution of electronic components. Line cards we deal with include Microchip,ALPS,ROHM,Xilinx,Pulse,ON,Everlight and Freescale. Main products comprise IC,Modules,Potentiometer,IC Socket,Relay,Connector.Our parts cover such applications as commercial,industrial, and automotives areas.

We are looking forward to setting up business relationship with you and hope to provide you with the best service and solution. Let us make a better world for our industry!



Contact us

Tel: +86-755-8981 8866 Fax: +86-755-8427 6832

Email & Skype: info@chipsmall.com Web: www.chipsmall.com

Address: A1208, Overseas Decoration Building, #122 Zhenhua RD., Futian, Shenzhen, China



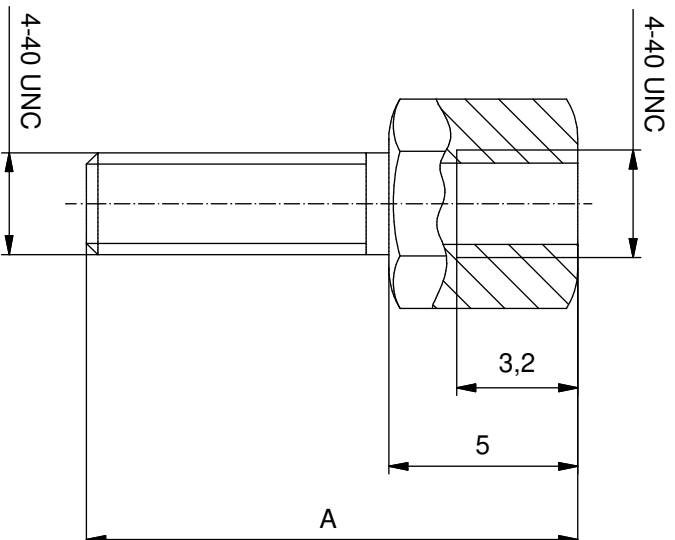
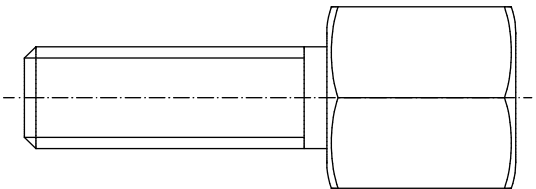

**Materials/
Werkstoffe:**
 Hex bolt/
 Sechskantbolzen: **Steel/
 Stahl**
**Plating/
 Veredelung:** see table/
 siehe Tabelle

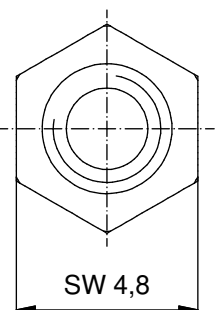
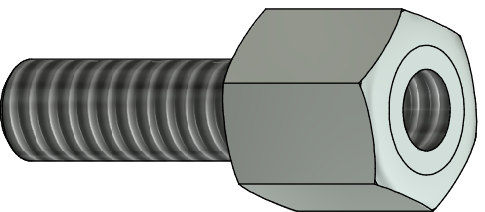

Ⓟ

A	Part no. / Artikel-Nr.:	Tin plated / Verzinkt
A-0.5	Nickel plated / Vernickelt	
13	740-331370	740-331340
16	740-331570	740-331540
19	740-331670	740-331640



dim. in mm

	Date/Datum	Name
drawn/ gez.	13.04.11	Gillnow
appd./ gepr.	13.04.11	Fischer



Hex bolt
 4-40 UNC / 4-40 UNC
 Sechskantbolzen
 4-40 UNC / 4-40 UNC

dwg no / Z.-nr.: **740KEI3A**

DIN-
A4

Index: b A6529 16.02.2017 J.L.
 Status: In Bearbeitung

Scale/Maßstab:
5:1

RoHS compliant/konform

1 / 1