



Chipsmall Limited consists of a professional team with an average of over 10 year of expertise in the distribution of electronic components. Based in Hongkong, we have already established firm and mutual-benefit business relationships with customers from,Europe,America and south Asia,supplying obsolete and hard-to-find components to meet their specific needs.

With the principle of “Quality Parts,Customers Priority,Honest Operation,and Considerate Service”,our business mainly focus on the distribution of electronic components. Line cards we deal with include Microchip,ALPS,ROHM,Xilinx,Pulse,ON,Everlight and Freescale. Main products comprise IC,Modules,Potentiometer,IC Socket,Relay,Connector.Our parts cover such applications as commercial,industrial, and automotives areas.

We are looking forward to setting up business relationship with you and hope to provide you with the best service and solution. Let us make a better world for our industry!



Contact us

Tel: +86-755-8981 8866 Fax: +86-755-8427 6832

Email & Skype: info@chipsmall.com Web: www.chipsmall.com

Address: A1208, Overseas Decoration Building, #122 Zhenhua RD., Futian, Shenzhen, China





Copyright FCI.

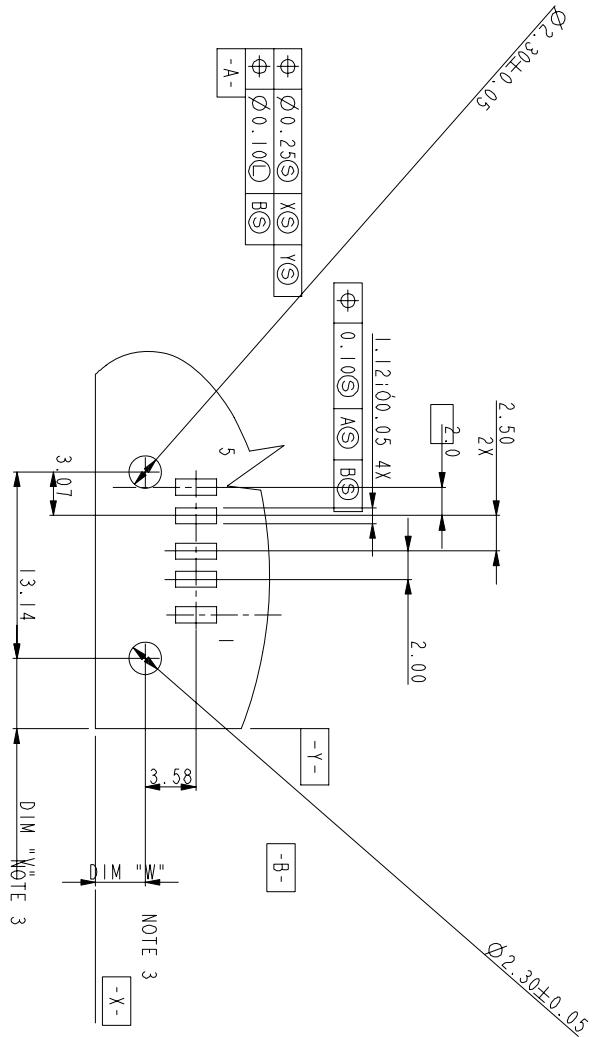
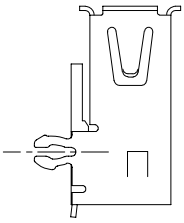
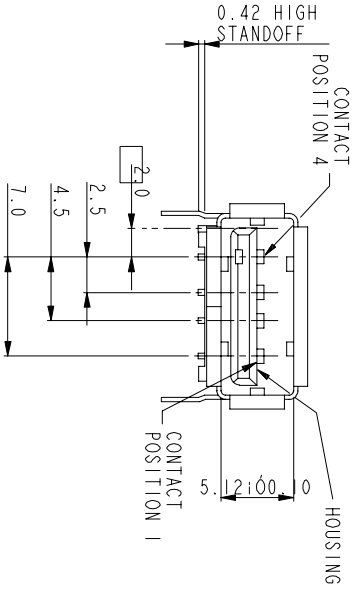
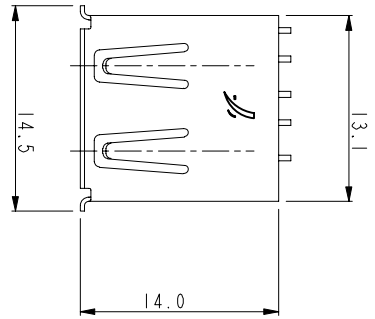

P.C. BOARD LAYOUT FOR 5 PIN 74626-X01XB

www.fciconnect.com		surface	tolerance	std	projection	MM
TOLERANCES UNLESS OTHERWISE SPECIFIED		ANGULAR	0.X	±0.3	size A4	
Dr	PETER	7/8/98	LINEAR	0.XX	±0.2	Scale 1:1
Eng	R Y LIU	7/8/98	Product family	±	ECN	EX-N-15753
Chr	R Y LIU	7/8/98	Appr	JENN TSAO	7/8/98	Spec ref

	USB REVERSED	74626	Rev. S
	RECEPTACLE SMT		
catalog no	CUSTOMER	sheet 2 of 3	

PRODUCT NUMBER CODE

74626 - X X X X P LF

BASE PRODUCT NUMBER

HOUSING COLOR OPTIONS

- 0 - WHITE
- 1 - BLACK
- 2 - WHITE + SHELL NICKEL PLATING ONLY

SENSOR CONTACT OPTION

- 0 - WITH SENSOR CONTACT
- 1 - WITHOUT SENSOR CONTACT

SHELL OPTIONS

- 1 - WITHOUT BACK SHIELD
- 3 - WITHOUT BACK SHIELD & NICKEL PLATING ONLY
- 5 - WITHOUT BACK SHIELD & NICKEL PLATING ONLY (SPECIAL MATERIAL FOR DURABILITY (2,000 CYCLES))

TERMINAL PLATING OPTION

- 0 - 1.25um Ni UNDERPLATE
- 0.76um GXT CONTACT AREA
- 2.50 um TIN/LEAD TAIL AREA

PACKAGING OPTION

- B - TUBES
- R - TAPE & REEL

DATE CODE

LEAD FREE

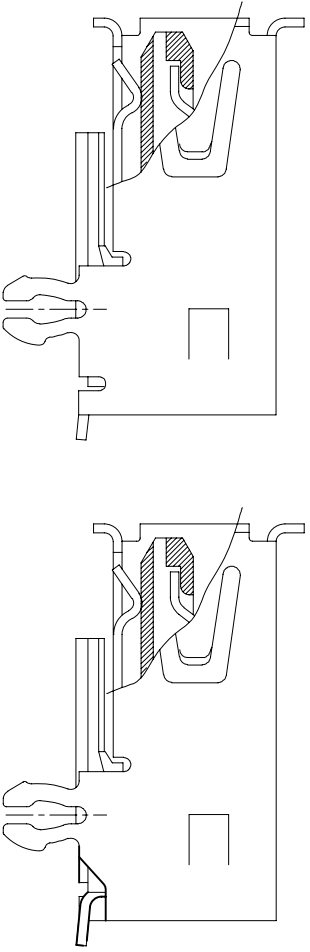

STYLE 1

STYLE 2

NOTES:

1. P/N'S WITH SUFFIX "LF" ARE LEAD FREE P/N'S
2. PACKING STANDARD GS-14-920 WILL BE APPLIED FOR LEAD FREE P/N'S
3. FOR LEAD FREE P/N, THE PRODUCT MEET EUROPEAN UNION DIRECTIVES AND OTHER COUNTRY REGULATION AS DESCRIBED IN GS-22-008
4. FOR LEAD FREE P/N, THE HOUSING WILL WITHSTAND EXPOSURE TO 260°C PEAK TEMPERATURE FOR 40 SECONDS IN A CONVECTION, INFRARED OR VAPOR PHASE REFLOW OVEN.
5. AVAILABLE P/N'S NOW IN FCI ARE

PART NUMBER	STYLE
74626-010XXLF	STYLE 1
74626-1010XXLF	STYLE 1
74626-0110XXLF	STYLE 1
74626-1130XXLF	STYLE 1
74626-2010XXLF	STYLE 2
74626-2110XXLF	STYLE 2
74626-1110XXLF	STYLE 1
74626-01S0XP1F	STYLE 2
74626-11S0XP1F	STYLE 2

www.fciconnect.com		surface	tolerance std	projection	MM
TOLERANCES UNLESS OTHERWISE SPECIFIED		ANGULAR	0.X	⊕	
Dr	PETER	7/8/98	±0.3	size	A4
Eng	R Y LIU	7/8/98	±0.2	LINEAR	0.XX
Chr	R Y LIU	7/8/98	±	ECN	EX-N15753
Appr	JENN TSAO	7/8/98	±	Product family	Spec ref

FCI	USB REVERSED	CUSTOMER	74626	Rev. S
	RECEPTACLE SMT			
catalog no		sheet	3 of 3	



Copyright FCI.

REV F - 28694-11