



Chipsmall Limited consists of a professional team with an average of over 10 year of expertise in the distribution of electronic components. Based in Hongkong, we have already established firm and mutual-benefit business relationships with customers from,Europe,America and south Asia,supplying obsolete and hard-to-find components to meet their specific needs.

With the principle of “Quality Parts,Customers Priority,Honest Operation,and Considerate Service”,our business mainly focus on the distribution of electronic components. Line cards we deal with include Microchip,ALPS,ROHM,Xilinx,Pulse,ON,Everlight and Freescale. Main products comprise IC,Modules,Potentiometer,IC Socket,Relay,Connector.Our parts cover such applications as commercial,industrial, and automotives areas.

We are looking forward to setting up business relationship with you and hope to provide you with the best service and solution. Let us make a better world for our industry!



Contact us

Tel: +86-755-8981 8866 Fax: +86-755-8427 6832

Email & Skype: info@chipsmall.com Web: www.chipsmall.com

Address: A1208, Overseas Decoration Building, #122 Zhenhua RD., Futian, Shenzhen, China



6

5

4

3

2

1

D

C

B

A

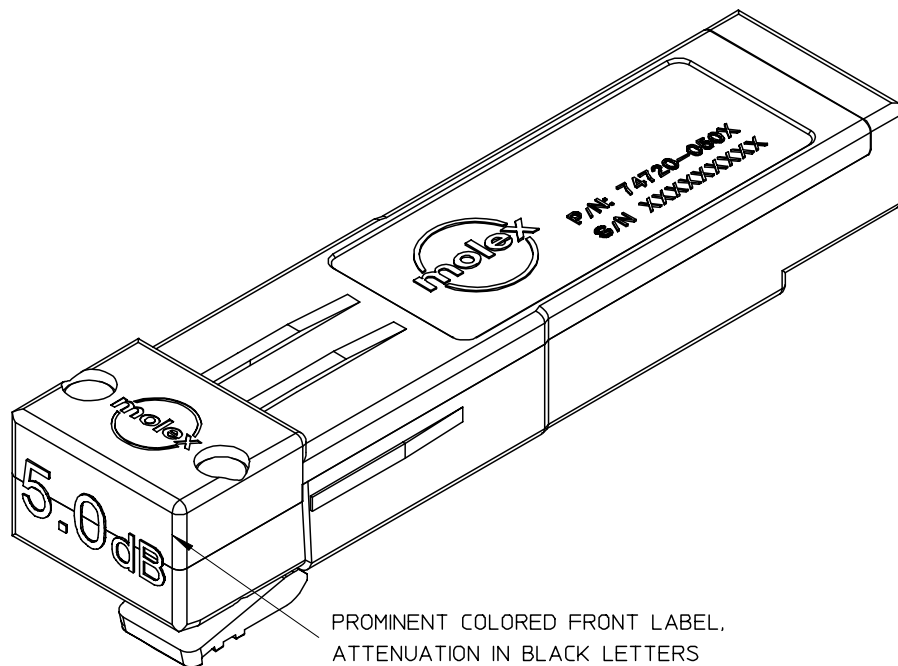

PROMINENT COLORED FRONT LABEL,
ATTENUATION IN BLACK LETTERS

1. Mates to SFP components which comply to standard MSA dimension specifications.
2. Support for:
 - Fibre channel data to 2.125 Gbps
 - Gigabit Ethernet data rates to 2.5 Gbps
 - infiniband data rates to 2.5 Gbps
3. Robust zinc die cast body, bright nickel plated. Mounts belly-to-belly using 0.093"+ boards.
4. Raised wedges assure electrical contact with surrounding EMI cage assembly.
5. Spring loaded latch releases with simple squeeze, and pull action.
6. 100 ohm impedance.
7. Supports serial ID functionality.
8. 3.3V or 5.0V supply.
9. Hot pluggable.

D

C

B

A

PART NUMBER	LABEL COLOR	PART DESCRIPTION
74720-0503	LIGHT GREEN	SERIAL ID, WITH 5.0 dB ATTENUATION
74720-0502	LIGHT BLUE	SERIAL ID, WITH 0.0 dB ATTENUATION
74720-0501	YELLOW	SERIAL ID, WITH 3.5 dB ATTENUATION

ENTER DESCRIPTION EC NO: USY2006-0271 DRWN: JERWIN CHKD: KLOYD APPR: KLOYD	2006/02/21 2006/03/03 2006/03/09	DESCRIPTION REV	QUALITY SYMBOLS ▼=0 ▽=0	GENERAL TOLERANCES (UNLESS SPECIFIED)		DIMENSION STYLE MM/IN		SCALE 2:1	DESIGN UNITS METRIC	THIRD ANGLE PROJECTION		
					mm	INCH	DRAWN BY DIRKERS	DATE 2002/05/01	TITLE SFP LOOPBACK ADAPTER			
				4 PLACES	± ---	± ---	CHECKED BY BRUSSELL	DATE 2002/05/01				
				3 PLACES	± ---	± .005	APPROVED BY RUSSELL	DATE 2002/05/01	MOLEX INCORPORATED			
				2 PLACES	± 0.13	± ---	MATERIAL NO. SEE CHART	DOCUMENT NO. SD-74720-0501				
1 PLACE	± ---	± ---	ANGULAR ±1/2°		THIS DRAWING CONTAINS INFORMATION THAT IS PROPRIETARY TO MOLEX INCORPORATED AND SHOULD NOT BE USED WITHOUT WRITTEN PERMISSION							
DRAFT WHERE APPLICABLE MUST REMAIN WITHIN DIMENSIONS												

5

4

3

2

1

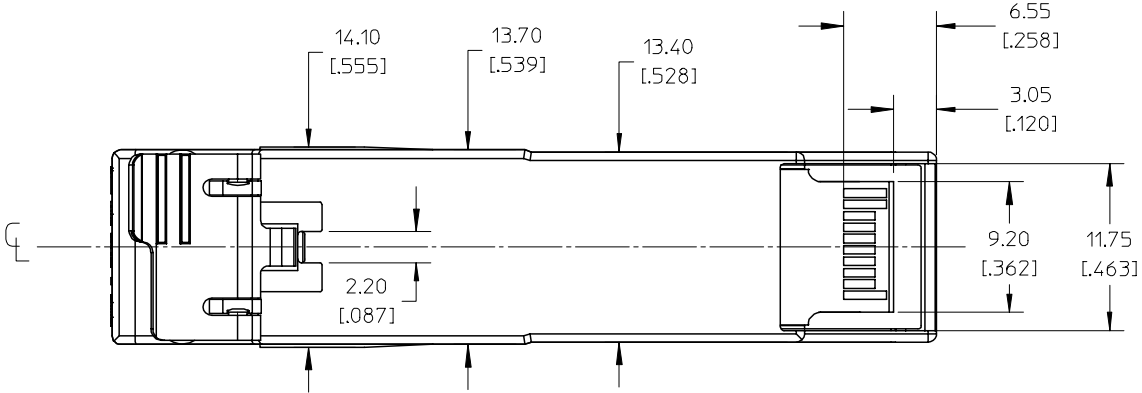
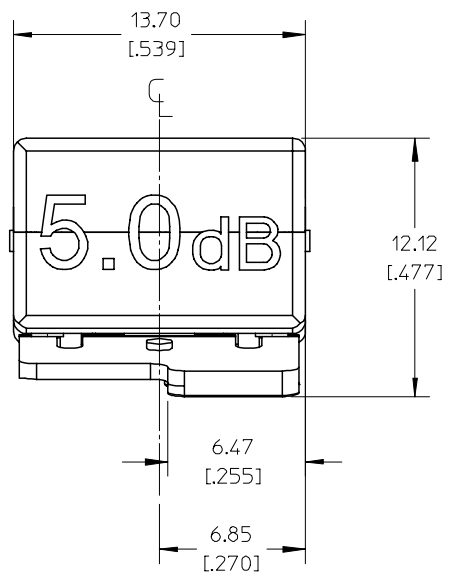
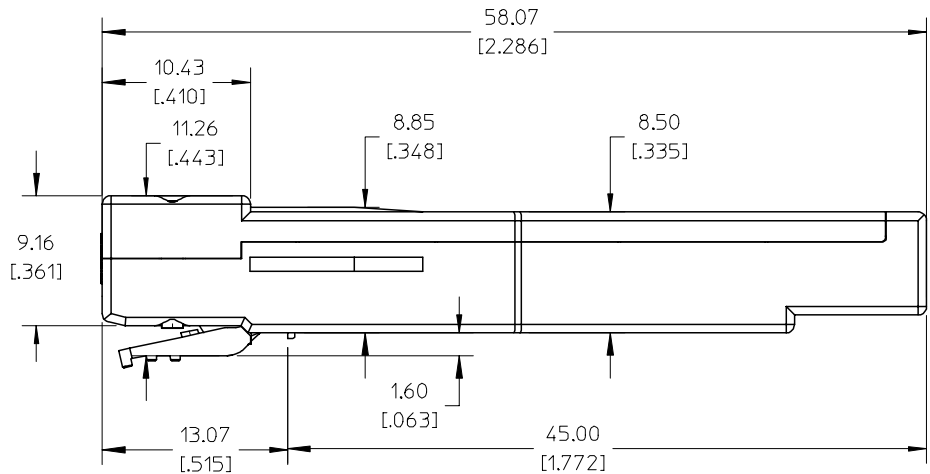

▲ ATTENUATION LEVEL FOR 74720-0502 SHOWN AS EXAMPLE.

ENTER DESCRIPTION EC NO: USY2006-0271 DRWN: JERWIN CHKD: KKLLOYD APPR: KKLLOYD	2006/02/21 2006/03/03 2006/03/09	QUALITY SYMBOLS ▽=0 ▽=0	GENERAL TOLERANCES (UNLESS SPECIFIED)		DIMENSION STYLE MM/IN		SCALE 2:1	DESIGN UNITS METRIC	THIRD ANGLE PROJECTION
				mm	INCH	DRAWN BY	DATE	TITLE SFP LOOPBACK ADAPTER	
			4 PLACES	± ---	± ---	DIRKERS	2002/05/01		
			3 PLACES	± ---	± .005	CHECKED BY	DATE		
2 PLACES	± 0.13	± ---	BRUSSELL	2002/05/01	APPROVED BY RUSSELL	DATE 2002/05/01	MOLEX INCORPORATED		
1 PLACE	± ---	± ---	MATERIAL NO. SEE CHART				DOCUMENT NO. SD-74720-0501		SHEET NO. 2 OF 3
DRAFT WHERE APPLICABLE MUST REMAIN WITHIN DIMENSIONS			ANGULAR ± 1/2°		THIS DRAWING CONTAINS INFORMATION THAT IS PROPRIETARY TO MOLEX INCORPORATED AND SHOULD NOT BE USED WITHOUT WRITTEN PERMISSION				

6

5

4

3

2

1

D

D

Top View
Cutaway

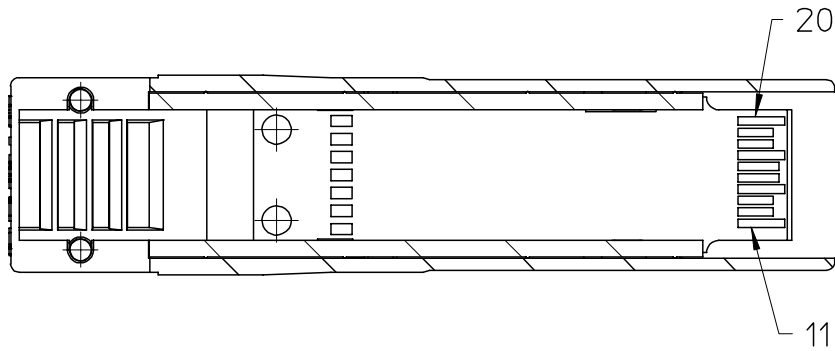

Bottom
View

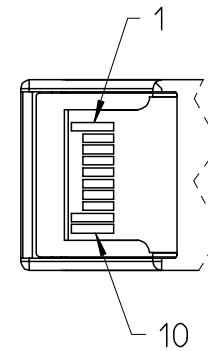

Gnd T	20	1	Gnd T
TD-	19	2	Tx Fault
TD+	18	3	Tx Disable
Gnd T	17	4	MOD-DEF(2)
VccT	16	5	MOD-DEF(1)
VccR	15	6	MOD-DEF(0)
Gnd R	14	7	Rate Select
RD+	13	8	LOS
RD-	12	9	Gnd R
Gnd R	11	10	Gnd R

B

B

A

A

ENTER DESCRIPTION EC NO: USY2006-0271 DRAWN: JERWIN 2006/02/21 CHKD: KKLLOYD 2006/03/03 APPR: KKLLOYD 2006/03/09 D	QUALITY SYMBOLS 	GENERAL TOLERANCES (UNLESS SPECIFIED)		DIMENSION STYLE MM/IN		SCALE 2:1	DESIGN UNITS METRIC	THIRD ANGLE PROJECTION	
			mm	INCH	DRAWN BY	DATE	TITLE SFP LOOPBACK ADAPTER		
		4 PLACES	± ---	± ---	DIRKERS	2002/05/01			
		3 PLACES	± ---	± .005	CHECKED BY	DATE	MOLEX INCORPORATED		
2 PLACES	± 0.13	± ---	BRUSSELL	2002/05/01					
1 PLACE	± ---	± ---	APPROVED BY	DATE	MATERIAL NO. SEE CHART		DOCUMENT NO. SD-74720-0501	SHEET NO. 3 OF 3	
ANGULAR ± 1/2°		RUSSELL		2002/05/01					
DRAFT WHERE APPLICABLE MUST REMAIN WITHIN DIMENSIONS				SIZE 		THIS DRAWING CONTAINS INFORMATION THAT IS PROPRIETARY TO MOLEX INCORPORATED AND SHOULD NOT BE USED WITHOUT WRITTEN PERMISSION			

5

4

3

2

1