



Chipsmall Limited consists of a professional team with an average of over 10 year of expertise in the distribution of electronic components. Based in Hongkong, we have already established firm and mutual-benefit business relationships with customers from,Europe,America and south Asia,supplying obsolete and hard-to-find components to meet their specific needs.

With the principle of “Quality Parts,Customers Priority,Honest Operation,and Considerate Service”,our business mainly focus on the distribution of electronic components. Line cards we deal with include Microchip,ALPS,ROHM,Xilinx,Pulse,ON,Everlight and Freescale. Main products comprise IC,Modules,Potentiometer,IC Socket,Relay,Connector.Our parts cover such applications as commercial,industrial, and automotives areas.

We are looking forward to setting up business relationship with you and hope to provide you with the best service and solution. Let us make a better world for our industry!



Contact us

Tel: +86-755-8981 8866 Fax: +86-755-8427 6832

Email & Skype: info@chipsmall.com Web: www.chipsmall.com

Address: A1208, Overseas Decoration Building, #122 Zhenhua RD., Futian, Shenzhen, China



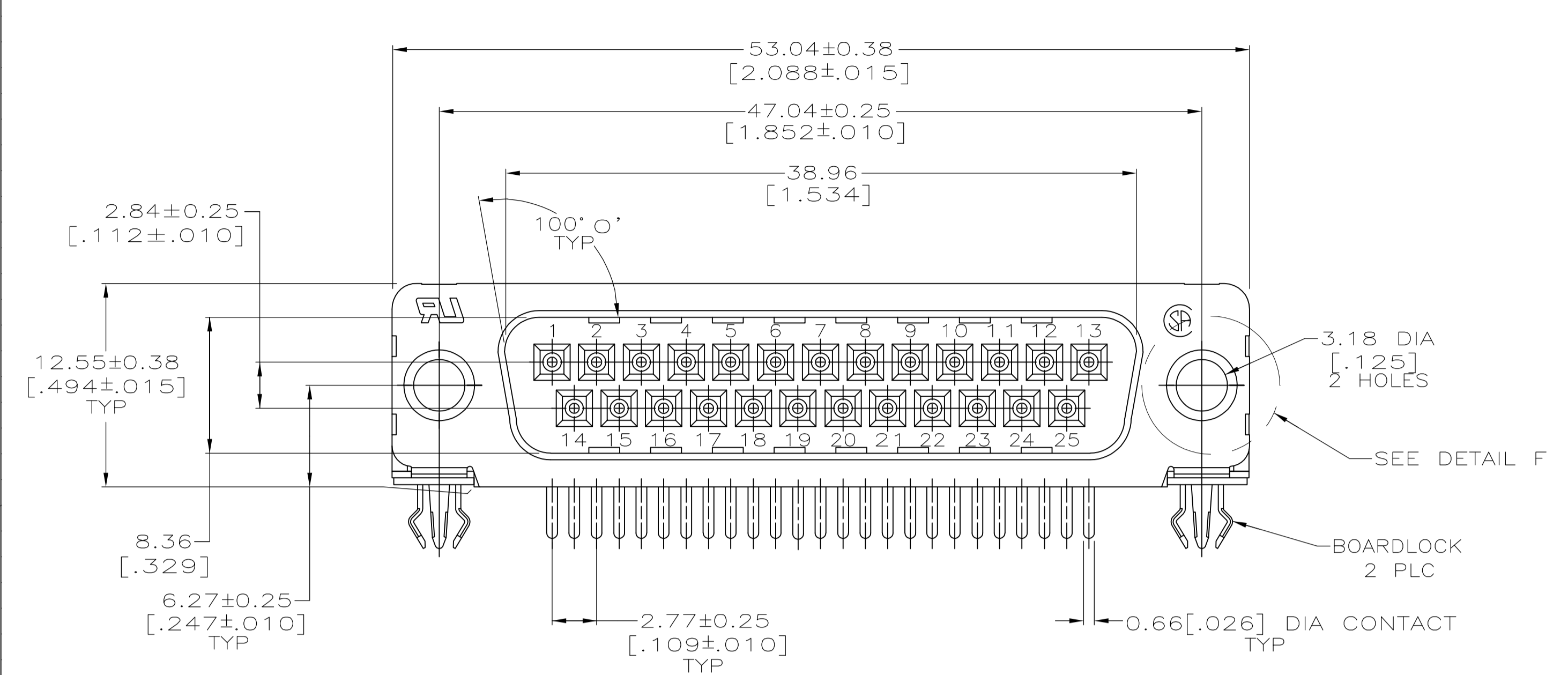

- ⚠ HOUSING: NYLON OR POLYESTER, FLAME RETARDANT 94V-0 RATED, GLASS FILLED, BLACK.
SHELLS: CARBON STEEL.
CONTACTS: BRASS.
BOARDLOCKS: COPPER ALLOY.
EYELETS: BRASS.
- ⚠ SHELLS: 2.54µm [.000100] MIN TIN OVER 1.27µm [.000050] MIN COPPER.
EYELETS: 5.08µm [.000200] MIN TIN OVER COPPER FLASH.
SCREWLOCKS AND INSERTS: CLEAR CHROMATE.
BOARDLOCKS AND CONTACTS: SEE TABLE.
- ⚠ GOLD FLASH ON THE MATING SURFACES, 2.54µm [.000100] MIN TIN OR TIN-LEAD PLATE ON THE SOLDER END, 1.27µm [.000050] MIN NICKEL UNDERPLATE ON THE ENTIRE CONTACT.
- ⚠ 0.76µm [.000030] MIN GOLD PLATE ON THE MATING SURFACES, 2.54µm [.000100] MIN TIN OR TIN-LEAD PLATE ON THE SOLDER END, 1.27µm [.000050] MIN NICKEL UNDERPLATE ON THE ENTIRE CONTACT
-OR-
GOLD FLASH OVER PALLADIUM-NICKEL PLATE, 0.76µm [.000030] MIN TOTAL ON THE MATING SURFACES, 2.54µm [.000100] MIN TIN OR TIN-LEAD PLATE ON THE SOLDER END, 1.27µm [.000050] MIN NICKEL UNDERPLATE ON THE ENTIRE CONTACT.
- ⚠ 5.08µm [.000200] MIN TIN-LEAD OVER 1.27µm [.000050] MIN NICKEL.
- ⚠ 5.08µm [.000200] MIN TIN OVER 1.27µm [.000050] MIN NICKEL.
- ⚠ OBSOLETE PARTS: OBSOLETE CIS STREAMLINING PER D.RENAUD/D.SINISI.

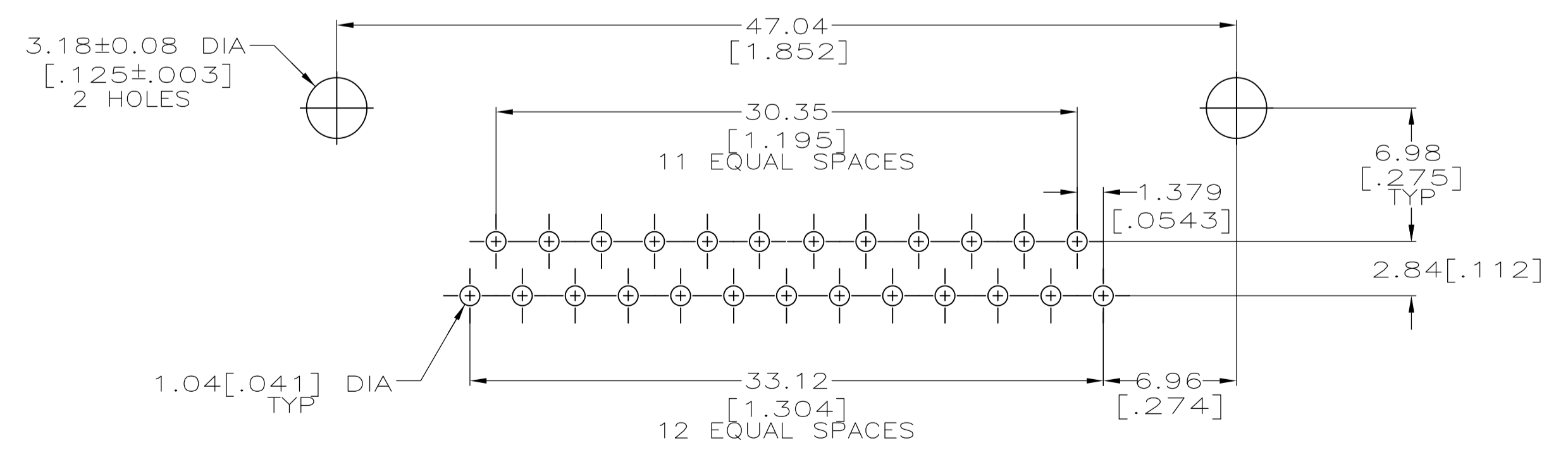
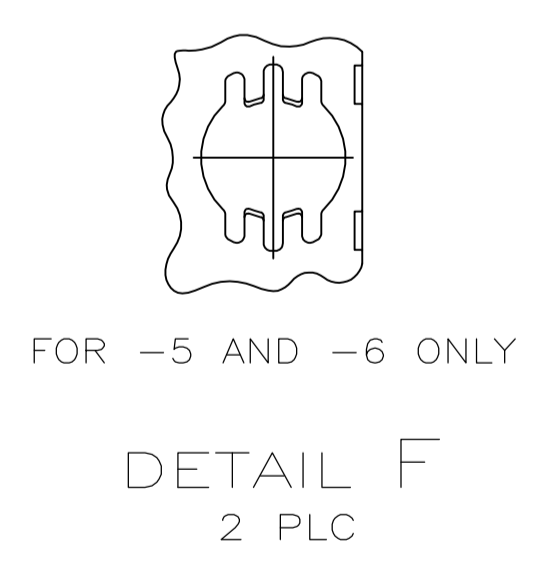
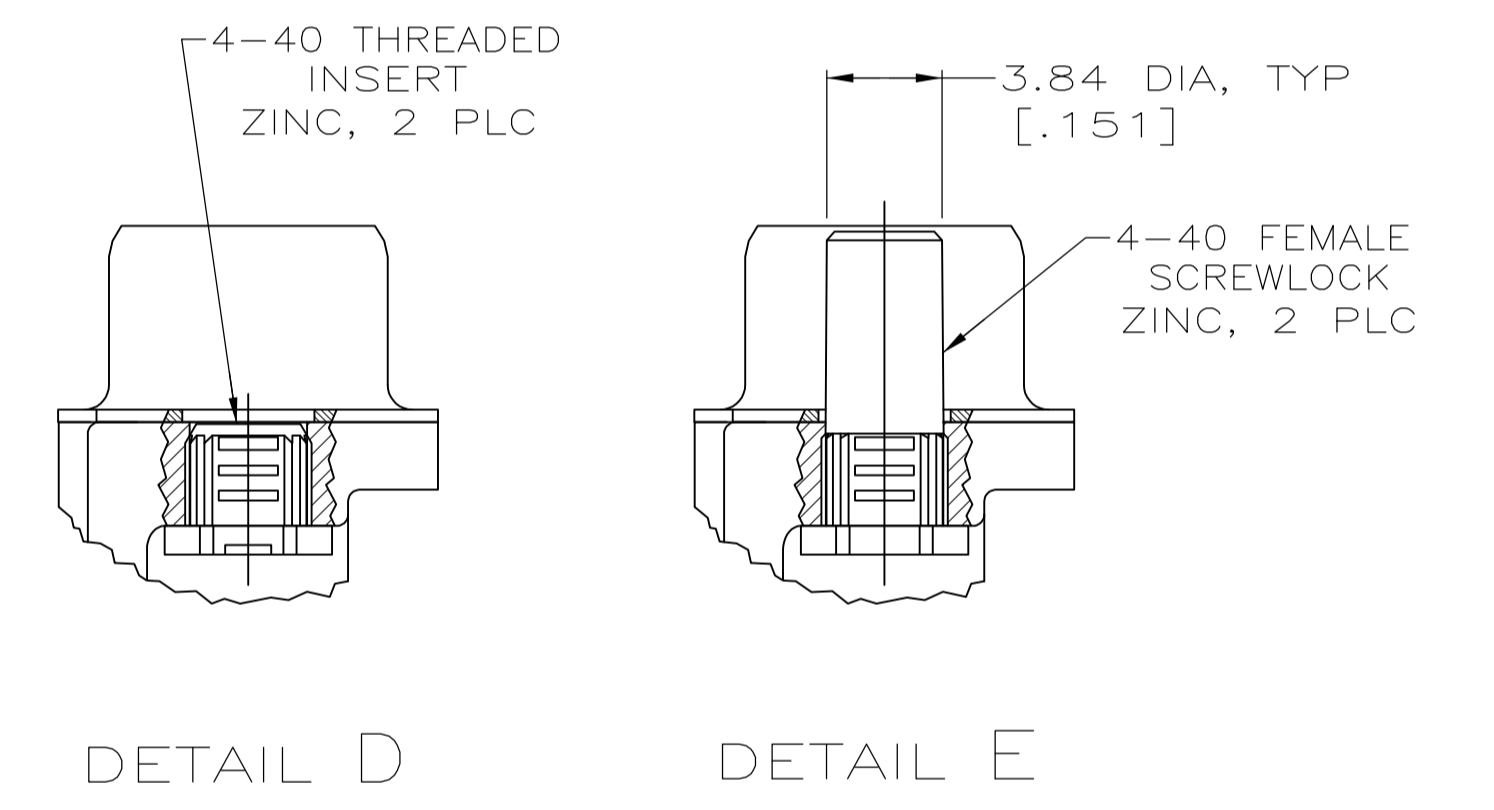
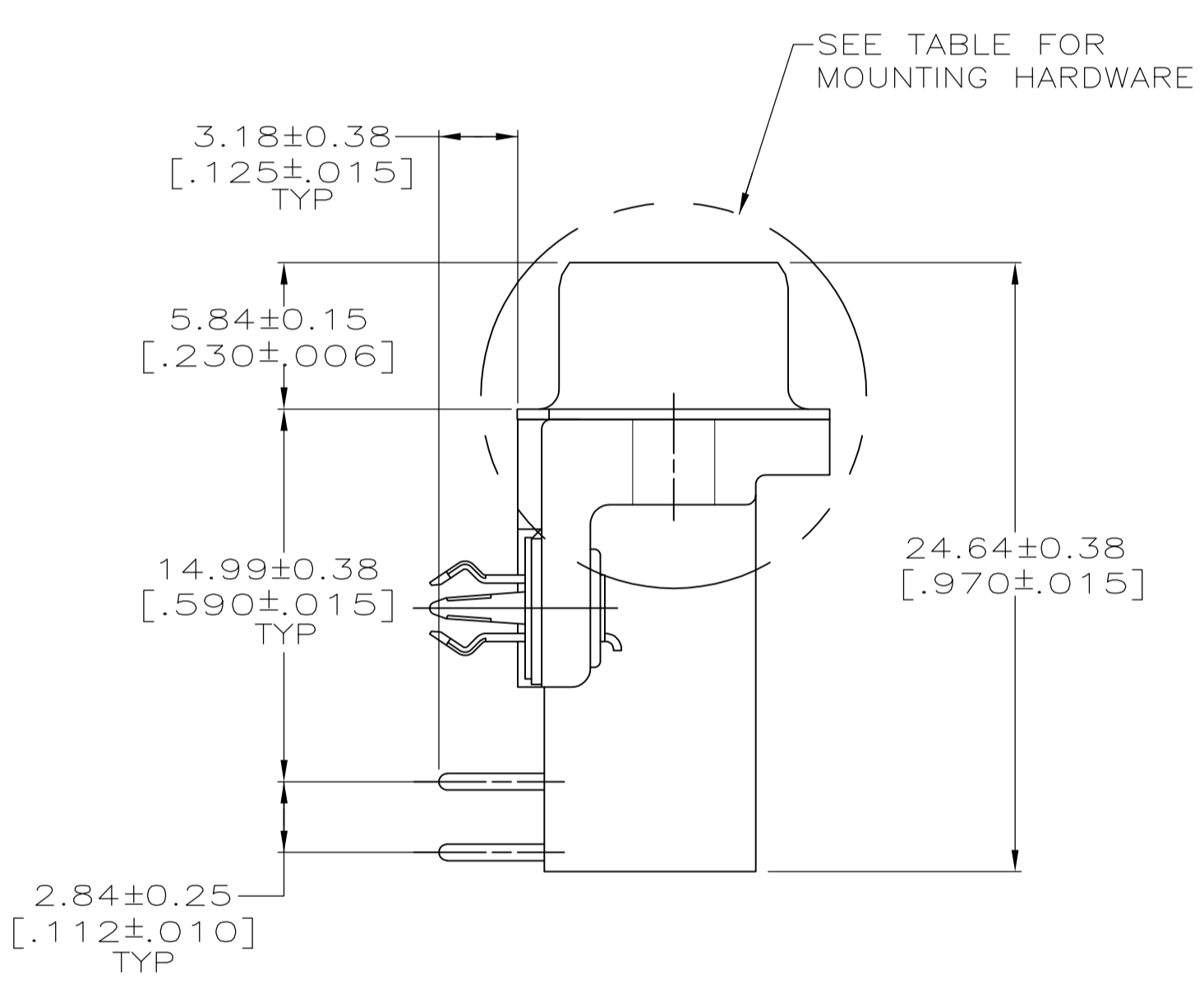
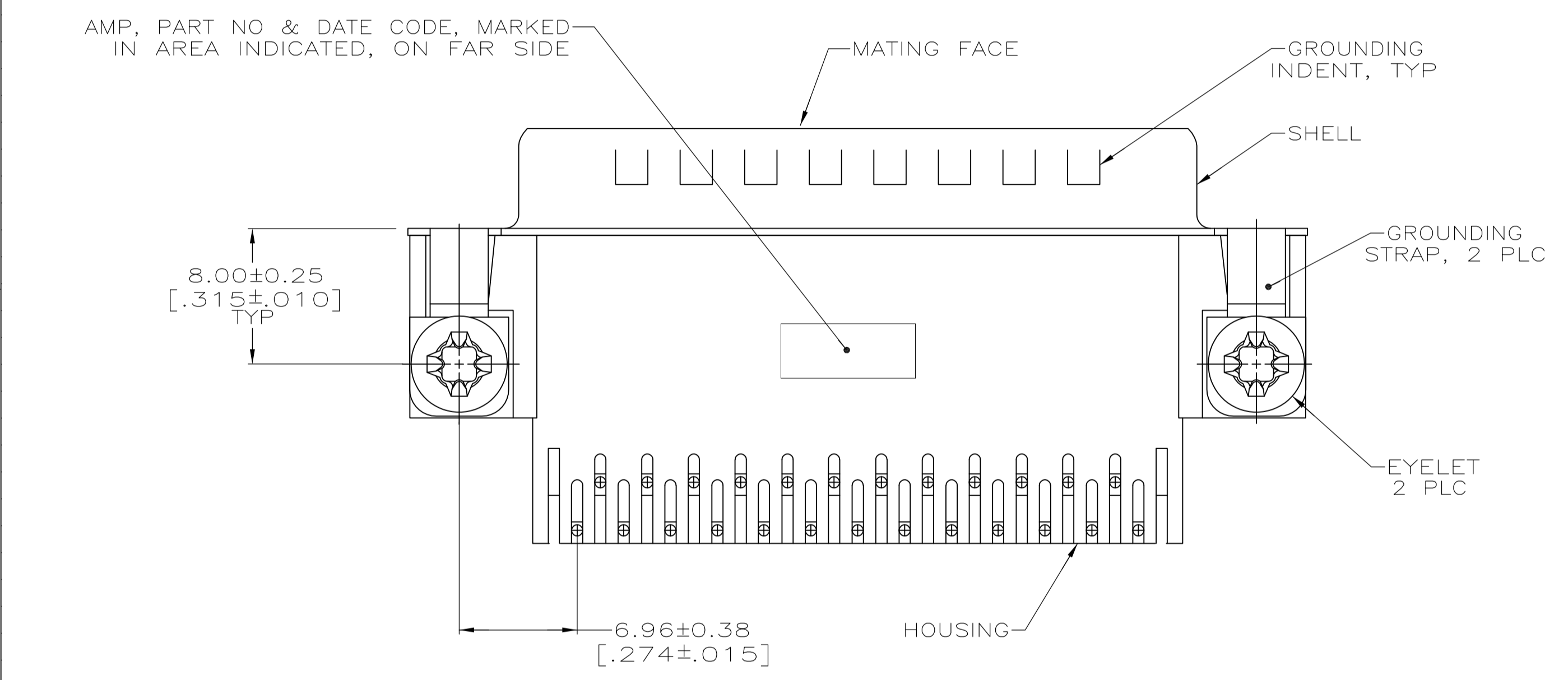

RECOMMENDED P.C. BOARD MOUNTING DIMENSIONS
P.C. BOARD THICKNESS: 1.57 [.062]

⚠ OBSOLETE	SEE DETAIL D	⚠ 6	⚠ 4	6-747834-7
	SEE DETAIL E	⚠ 5	⚠ 4	747834-6
SUPSD BY 747834-4	SEE DETAIL E	⚠ 5	⚠ 3	747834-5
⚠ SUPERSEDED	SEE DETAIL D	⚠ 5	⚠ 4	747834-4
SUPSD BY 747834-4	SEE DETAIL D	⚠ 5	⚠ 3	747834-3
⚠ OBSOLETE	-	⚠ 5	⚠ 4	747834-2
⚠ OBSOLETE	-	⚠ 5	⚠ 3	747834-1
	MOUNTING HARDWARE	BOARDLOCK FINISH	CONTACT FINISH	PART NUMBER

THIS DRAWING IS A CONTROLLED DOCUMENT. DIMENSIONING AND TOLERANCING PER ASME Y14.5M-2009.

DIMENSIONS:	TOLERANCES UNLESS OTHERWISE SPECIFIED:	APVD	DATE	NAME
mm [INCHES]	0 PLC ± - 1 PLC ± - 2 PLC ± - 3 PLC ± 0.13 [.005] 4 PLC ± - ANGLES ± ±	W.G. LENKER R. STONE M.D. GALLOWAY	16-NOV-89 05-FEB-90 06-FEB-90	PLUG ASSEMBLY, SIZE 3, 25 POSITION, RIGHT ANGLE, FRONT METAL SHELL, .590 SERIES, BOARDLOCKS, AMPLIMITE® HD-20
MATERIAL	FINISH	SIZE	CAGE CODE	DRAWING NO
⚠	⚠	114-40010	A1	00779
		WEIGHT	SCALE	SHEET
			4:1	1 of 1

CUSTOMER DRAWING