



Chipsmall Limited consists of a professional team with an average of over 10 year of expertise in the distribution of electronic components. Based in Hongkong, we have already established firm and mutual-benefit business relationships with customers from,Europe,America and south Asia,supplying obsolete and hard-to-find components to meet their specific needs.

With the principle of “Quality Parts,Customers Priority,Honest Operation,and Considerate Service”,our business mainly focus on the distribution of electronic components. Line cards we deal with include Microchip,ALPS,ROHM,Xilinx,Pulse,ON,Everlight and Freescale. Main products comprise IC,Modules,Potentiometer,IC Socket,Relay,Connector.Our parts cover such applications as commercial,industrial, and automotives areas.

We are looking forward to setting up business relationship with you and hope to provide you with the best service and solution. Let us make a better world for our industry!



Contact us

Tel: +86-755-8981 8866 Fax: +86-755-8427 6832

Email & Skype: info@chipsmall.com Web: www.chipsmall.com

Address: A1208, Overseas Decoration Building, #122 Zhenhua RD., Futian, Shenzhen, China



74ABT245 Octal Bi-Directional Transceiver with 3-STATE Outputs

General Description

The ABT245 contains eight non-inverting bidirectional buffers with 3-STATE outputs and is intended for bus-oriented applications. Current sinking capability is 64 mA on both the A and B ports. The Transmit/Receive (T/R) input determines the direction of data flow through the bidirectional transceiver. Transmit (active HIGH) enables data from A Ports to B Ports; Receive (active LOW) enables data from B Ports to A Ports. The Output Enable input, when HIGH, disables both A and B ports by placing them in a HIGH Z condition.

Features

- Bidirectional non-inverting buffers
- A and B output sink capability of 64 mA, source capability of 32 mA
- Guaranteed output skew
- Guaranteed multiple output switching specifications
- Output switching specified for both 50 pF and 250 pF loads
- Guaranteed simultaneous switching, noise level and dynamic threshold performance
- Guaranteed latchup protection
- High impedance glitch-free bus loading during entire power up and power down cycle
- Non-destructive hot insertion capability
- Disable time is less than enable time to avoid bus contention

Ordering Code:

Order Number	Package Number	Package Description
74ABT245CSC	M20B	20-Lead Small Outline Integrated Circuit (SOIC), JEDEC MS-013, 0.300" Wide Body
74ABT245CSJ	M20D	20-Lead Small Outline Package (SOP), EIAJ TYPE II, 5.3mm Wide
74ABT245CMSA	MSA20	20-Lead Shrink Small Outline Package (SSOP), EIAJ TYPE II, 5.3mm Wide
74ABT245CMTC	MTC20	20-Lead Thin Shrink Small Outline Package (TSSOP), JEDEC MO-153, 4.4mm Wide
74ABT245CPC	N20A	20-Lead Plastic Dual-In-Line Package (PDIP), JEDEC MS-001, 0.300" Wide

Device also available in Tape and Reel. Specify by appending suffix letter "X" to the ordering code.

Connection Diagram

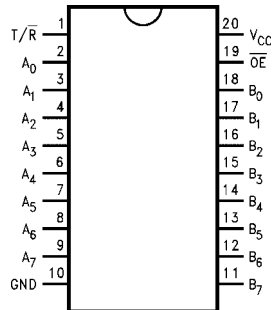

Pin Descriptions

Pin Names	Description
\overline{OE}	Output Enable Input (Active LOW)
T/R	Transmit/Receive Input
A ₀ -A ₇	Side A Inputs or 3-STATE Outputs
B ₀ -B ₇	Side B Inputs or 3-STATE Outputs

Logic Symbol

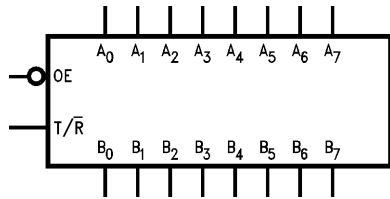

Truth Table

Inputs		Output
OE	T/R	
L	L	Bus B Data to Bus A
L	H	Bus A Data to Bus B
H	X	HIGH Z State

H = HIGH Voltage Level
 L = LOW Voltage Level
 X = Immaterial

Logic Diagram

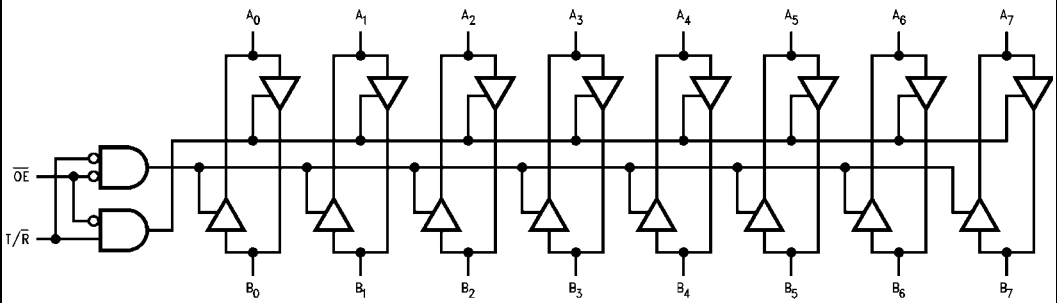

Absolute Maximum Ratings(Note 1)

Storage Temperature	-65°C to +150°C
Ambient Temperature under Bias	-55°C to +125°C
Junction Temperature under Bias	-55°C to +150°C
V _{CC} Pin Potential to Ground Pin	-0.5V to +7.0V
Input Voltage (Note 2)	-0.5V to +7.0V
Input Current (Note 2)	-30 mA to +5.0 mA
Voltage Applied to Any Output in the Disabled or Power-off State	-0.5V to 5.5V
in the HIGH State	-0.5V to V _{CC}
Current Applied to Output in LOW State (Max)	twice the rated I _{OL} (mA)
DC Latchup Source Current	-500 mA
Over Voltage Latchup (I/O)	10V

Recommended Operating Conditions

Free Air Ambient Temperature	-40°C to +85°C
Supply Voltage	+4.5V to +5.5V
Minimum Input Edge Rate ($\Delta V/\Delta t$)	
Data Input	50 mV/ns
Enable Input	20 mV/ns

Note 1: Absolute maximum ratings are values beyond which the device may be damaged or have its useful life impaired. Functional operation under these conditions is not implied.

Note 2: Either voltage limit or current limit is sufficient to protect inputs

DC Electrical Characteristics

Symbol	Parameter	Min	Typ	Max	Units	V _{CC}	Conditions
V _{IH}	Input HIGH Voltage	2.0			V		Recognized HIGH Signal
V _{IL}	Input LOW Voltage			0.8	V		Recognized LOW Signal
V _{CD}	Input Clamp Diode Voltage			-1.2	V	Min	I _{IN} = -18 mA (\overline{OE} , T/ \overline{R})
V _{OH}	Output HIGH Voltage	2.5			V	Min	I _{OH} = -3 mA (A _n , B _n)
		2.0			V	Min	I _{OH} = -32 mA (A _n , B _n)
V _{OL}	Output LOW Voltage			0.55	V	Min	I _{OL} = 64 mA (A _n , B _n)
I _{IH}	Input HIGH Current			1	μA	Max	V _{IN} = 2.7V (\overline{OE} , T/ \overline{R})
				1	μA	Max	V _{IN} = V _{CC} (\overline{OE} , T/ \overline{R})
I _{BVI}	Input HIGH Current Breakdown Test			7	μA	Max	V _{IN} = 7.0V (\overline{OE} , T/ \overline{R})
I _{BVIT}	Input HIGH Current Breakdown Test (I/O)			100	μA	Max	V _{IN} = 5.5V (A _n , B _n)
I _{IL}	Input LOW Current			-1	μA	Max	V _{IN} = 0.5V (\overline{OE} , T/ \overline{R})
				-1	μA	Max	V _{IN} = 0.0V (\overline{OE} , T/ \overline{R})
V _{ID}	Input Leakage Test	4.75			V	0.0	I _{ID} = 1.9 μA (\overline{OE} , T/ \overline{R}) All Other Pins Grounded
I _{IH} + I _{OZH}	Output Leakage Current			10	μA	0 - 5.5V	V _{OUT} = 2.7V (A _n , B _n); \overline{OE} = 2.0V
I _{IL} + I _{OZL}	Output Leakage Current			-10	μA	0 - 5.5V	V _{OUT} = 0.5V (A _n , B _n); \overline{OE} = 2.0V
I _{OS}	Output Short-Circuit Current	-100		-275	mA	Max	V _{OUT} = 0.0V (A _n , B _n)
I _{C_{EX}}	Output HIGH Leakage Current			50	μA	Max	V _{OUT} = V _{CC} (A _n , B _n)
I _{ZZ}	Bus Drainage Test			100	μA	0.0	V _{OUT} = 5.5V (A _n , B _n); All Others GND
I _{C_{CH}}	Power Supply Current			50	μA	Max	All Outputs HIGH
I _{C_{CL}}	Power Supply Current			30	mA	Max	All Outputs LOW
I _{C_{CZ}}	Power Supply Current			50	μA	Max	\overline{OE} = V _{CC} , T/ \overline{R} = GND or V _{CC} ; All Other GND or V _{CC}
I _{C_{CT}}	Additional I _{CC} /Input			2.5	mA	Max	V _I = V _{CC} - 2.1V
	Outputs Enabled			2.5	mA	Max	\overline{OE} , T/ \overline{R} V _I = V _{CC} - 2.1V
	Outputs 3-STATE			50	μA	Max	Data Input V _I = V _{CC} - 2.1V
	Outputs 3-STATE						All Others at V _{CC} or GND.
I _{C_{CD}}	Dynamic I _{CC}	No Load		0.1	mA/ MHz	Max	Outputs Open \overline{OE} = GND, T/ \overline{R} = GND or V _{CC} One Bit Toggling, 50% Duty Cycle

DC Electrical Characteristics

(SOIC package)

Symbol	Parameter	Min	Typ	Max	Units	V _{CC}	Conditions C _L = 50 pF, R _L = 500Ω
V _{OLP}	Quiet Output Maximum Dynamic V _{OL}		0.7	1.0	V	5.0	T _A = 25°C (Note 3)
V _{OLV}	Quiet Output Minimum Dynamic V _{OL}	-1.3	-1.0		V	5.0	T _A = 25°C (Note 3)
V _{OHV}	Minimum HIGH Level Dynamic Output Voltage	2.7	3.1		V	5.0	T _A = 25°C (Note 5)
V _{IHD}	Minimum HIGH Level Dynamic Input Voltage	2.0	1.7		V	5.0	T _A = 25°C (Note 4)
V _{ILD}	Maximum LOW Level Dynamic Input Voltage		0.9	0.6	V	5.0	T _A = 25°C (Note 4)

Note 3: Max number of outputs defined as (n). n-1 data inputs are driven 0V to 3V. One output at LOW. Guaranteed, but not tested.

Note 4: Max number of data inputs (n) switching. n-1 inputs switching 0V to 3V. Input-under-test switching: 3V to threshold (V_{ILD}), 0V to threshold (V_{IHD}). Guaranteed, but not tested.

Note 5: Max number of outputs defined as (n). n – 1 data inputs are driven 0V to 3V. One output HIGH. Guaranteed, but not tested.

AC Electrical Characteristics

(SOIC and SSOP package)

Symbol	Parameter	T _A = +25°C V _{CC} = +5V C _L = 50 pF			T _A = -55°C to +125°C V _{CC} = 4.5V–5.5V C _L = 50 pF		T _A = -40°C to +85°C V _{CC} = 4.5V–5.5V C _L = 50 pF		Units
		Min	Typ	Max	Min	Max	Min	Max	
t _{PLH}	Propagation Delay	1.0	2.1	3.6	1.0	4.8	1.0	3.6	ns
t _{PHL}	Data to Outputs	1.0	2.4	3.6	1.0	4.8	1.0	3.6	
t _{PZH}	Output Enable	1.5	3.2	6.0	1.0	6.7	1.5	6.0	ns
t _{PZL}	Time	1.5	3.7	6.0	2.0	7.5	1.5	6.0	
t _{PHZ}	Output Disable	1.0	3.6	6.1	1.7	7.4	1.0	6.1	ns
t _{PLZ}	Time	1.0	3.3	5.6	1.7	6.5	1.0	5.6	

Extended AC Electrical Characteristics

(SOIC package)

Symbol	Parameter	-40°C to +85°C V _{CC} = 4.5V–5.5V C _L = 50 pF 8 Outputs Switching (Note 6)			T _A = -40°C to +85°C V _{CC} = 4.5V–5.5V C _L = 250 pF 1 Output Switching (Note 7)		T _A = -40°C to +85°C V _{CC} = 4.5V–5.5V C _L = 250 pF 8 Outputs Switching (Note 8)		Units
		Min	Typ	Max	Min	Max	Min	Max	
t _{TOGGLE}	Max Toggle Frequency		100						MHz
t _{PLH}	Propagation Delay	1.5		5.0	1.5	6.0	2.5	8.5	ns
t _{PHL}	Data to Outputs	1.5		5.0	1.5	6.0	2.5	8.5	
t _{PZH}	Output Enable Time	1.5		6.5	2.5	7.5	2.5	9.5	ns
t _{PZL}	Time	1.5		6.5	2.5	7.5	2.5	11.0	
t _{PHZ}	Output Disable Time	1.0		6.5	(Note 9)		(Note 9)		ns
t _{PLZ}	Time	1.0		5.6	(Note 9)		(Note 9)		

Note 6: This specification is guaranteed but not tested. The limits apply to propagation delays for all paths described switching in phase (i.e., all LOW-to-HIGH, HIGH-to-LOW, etc.).

Note 7: This specification is guaranteed but not tested. The limits represent propagation delay with 250 pF load capacitors in place of the 50 pF load capacitors in the standard AC load. This specification pertains to single output switching only.

Note 8: This specification is guaranteed but not tested. The limits represent propagation delays for all paths described switching in phase (i.e., all LOW-to-HIGH, HIGH-to-LOW, etc.) with 250 pF load capacitors in place of the 50 pF load capacitors in the standard AC load.

Note 9: The 3-STATE delays are dominated by the RC network (500Ω, 250 pF) on the output and have been excluded from the datasheet.

Skew (SOIC package)				
Symbol	Parameter	$T_A = -40^\circ\text{C to } +85^\circ\text{C}$ $V_{CC} = 4.5\text{V} - 5.5\text{V}$ $C_L = 50\text{ pF}$ 8 Outputs Switching (Note 12)	$T_A = -40^\circ\text{C to } +85^\circ\text{C}$ $V_{CC} = 4.5\text{V} - 5.5\text{V}$ $C_L = 250\text{ pF}$ 8 Outputs Switching (Note 13)	Units
		Max	Max	
t_{OSHL} (Note 10)	Pin to Pin Skew HL Transitions	1.3	2.3	ns
t_{OSLH} (Note 10)	Pin to Pin Skew LH Transitions	1.0	1.8	ns
t_{PS} (Note 14)	Duty Cycle LH-HL Skew	2.0	3.5	ns
t_{OST} (Note 10)	Pin to Pin Skew LH/HL Transitions	2.0	3.5	ns
t_{PV} (Note 11)	Device to Device Skew LH/HL Transitions	2.0	3.5	ns
<p>Note 10: Skew is defined as the absolute value of the difference between the actual propagation delays for any two separate outputs of the same device. The specification applies to any outputs switching HIGH-to-LOW (t_{OSHL}), LOW-to-HIGH (t_{OSLH}), or any combination switching LOW-to-HIGH and/or HIGH-to-LOW (t_{OST}). The specification is guaranteed but not tested.</p> <p>Note 11: Propagation delay variation for a given set of conditions (i.e., temperature and V_{CC}) from device to device. This specification is guaranteed but not tested.</p> <p>Note 12: This specification is guaranteed but not tested. The limits apply to propagation delays for all paths described switching in phase (i.e., all LOW-to-HIGH, HIGH-to-LOW, etc.)</p> <p>Note 13: These specifications guaranteed but not tested. The limits represent propagation delays with 250 pF load capacitors in place of the 50 pF load capacitors in the standard AC load.</p> <p>Note 14: This describes the difference between the delay of the LOW-to-HIGH and the HIGH-to-LOW transition on the same pin. It is measured across all the outputs (drivers) on the same chip, the worst (largest delta) number is the guaranteed specification. This specification is guaranteed but not tested.</p>				
Capacitance				
Symbol	Parameter	Typ	Units	Conditions $T_A = 25^\circ\text{C}$
C_{IN}	Input Capacitance	5.0	pF	$V_{CC} = 0\text{V}$ (\overline{OE} , $\overline{T\overline{R}}$)
$C_{I/O}$ (Note 15)	I/O Capacitance	11.0	pF	$V_{CC} = 5.0\text{V}$ (A_n , B_n)
<p>Note 15: $C_{I/O}$ is measured at frequency $f = 1\text{ MHz}$, per MIL-STD-883, Method 3012.</p>				

AC Loading

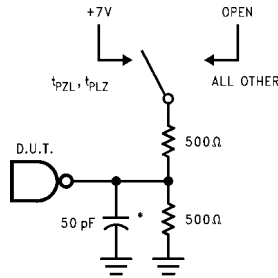

*Includes jig and probe capacitance

FIGURE 1. Standard AC Test Load

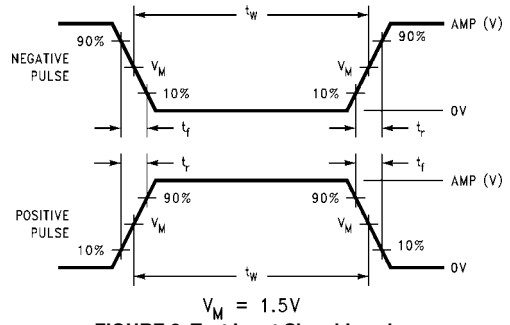

FIGURE 2. Test Input Signal Levels

Amplitude	Rep. Rate	t_w	t_r	t_f
3.0V	1 MHz	500 ns	2.5 ns	2.5 ns

FIGURE 3. Test Input Signal Requirements

AC Waveforms

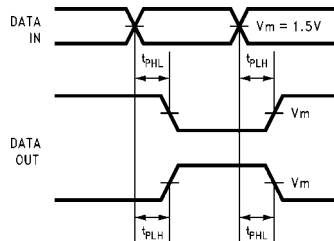

FIGURE 4. Propagation Delay Waveforms for Inverting and Non-Inverting Functions

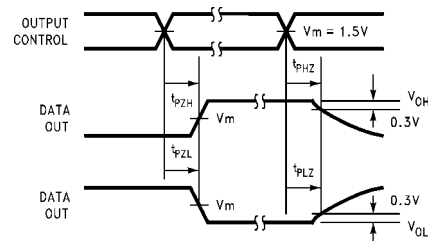

FIGURE 6. 3-STATE Output HIGH and LOW Enable and Disable Times

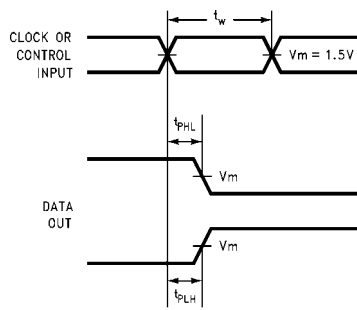

FIGURE 5. Propagation Delay, Pulse Width Waveforms

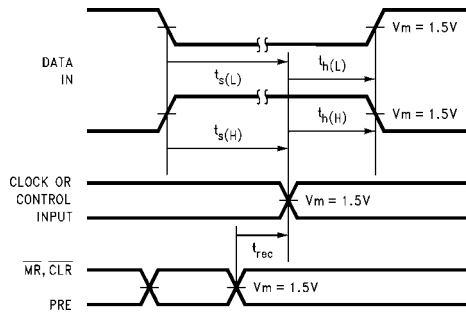

FIGURE 7. Setup Time, Hold Time and Recovery Time Waveforms

Physical Dimensions inches (millimeters) unless otherwise noted



**20-Lead Small Outline Integrated Circuit (SOIC), JEDEC MS-013, 0.300" Wide Body
Package Number M20B**

Physical Dimensions inches (millimeters) unless otherwise noted (Continued)

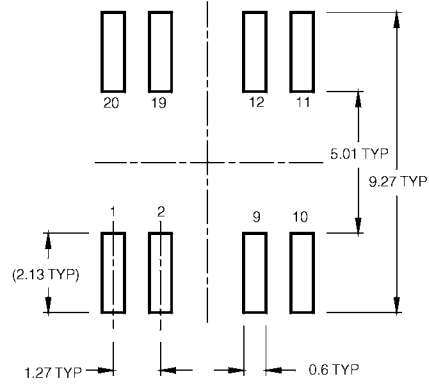
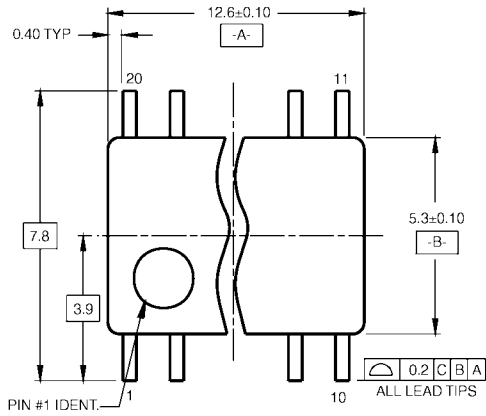

LAND PATTERN RECOMMENDATION

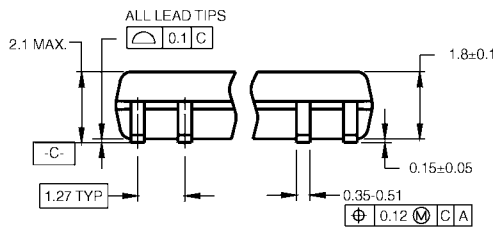

DIMENSIONS ARE IN MILLIMETERS

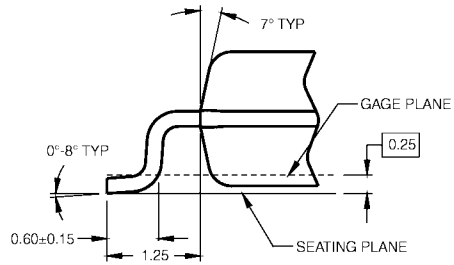
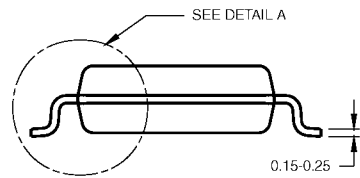

DETAIL A

- NOTES:
- A. CONFORMS TO EIAJ EDR-7320 REGISTRATION, ESTABLISHED IN DECEMBER, 1998.
 - B. DIMENSIONS ARE IN MILLIMETERS.
 - C. DIMENSIONS ARE EXCLUSIVE OF BURRS, MOLD FLASH, AND TIE BAR EXTRUSIONS.

M20DRevB1

**20-Lead Small Outline Package (SOP), EIAJ TYPE II, 5.3mm Wide
Package Number M20D**

Physical Dimensions inches (millimeters) unless otherwise noted (Continued)

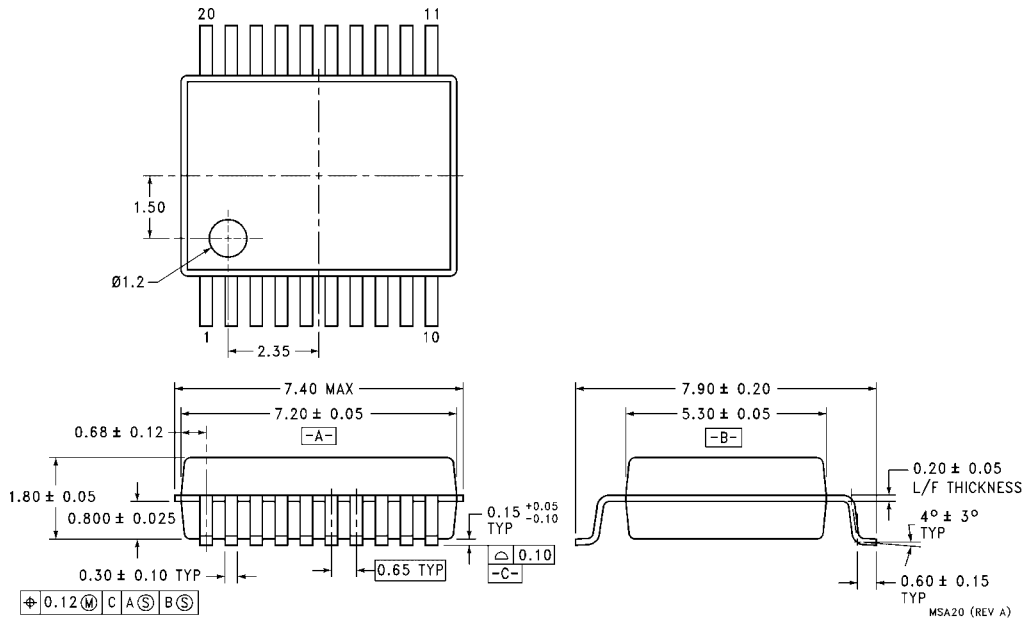

**20-Lead Shrink Small Outline Package (SSOP), EIAJ TYPE II, 5.3mm Wide
Package Number MSA20**

Physical Dimensions inches (millimeters) unless otherwise noted (Continued)

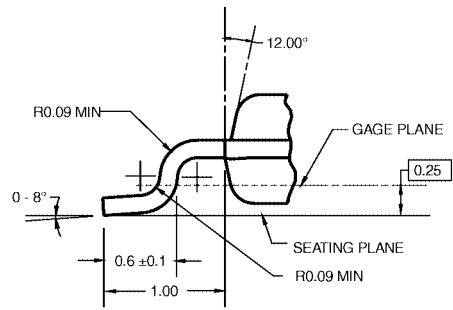
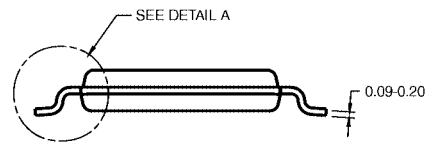
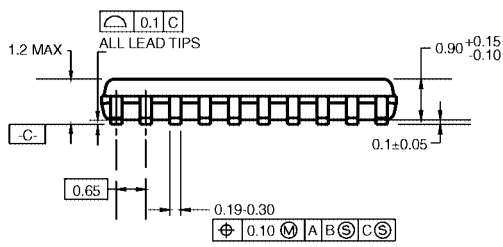
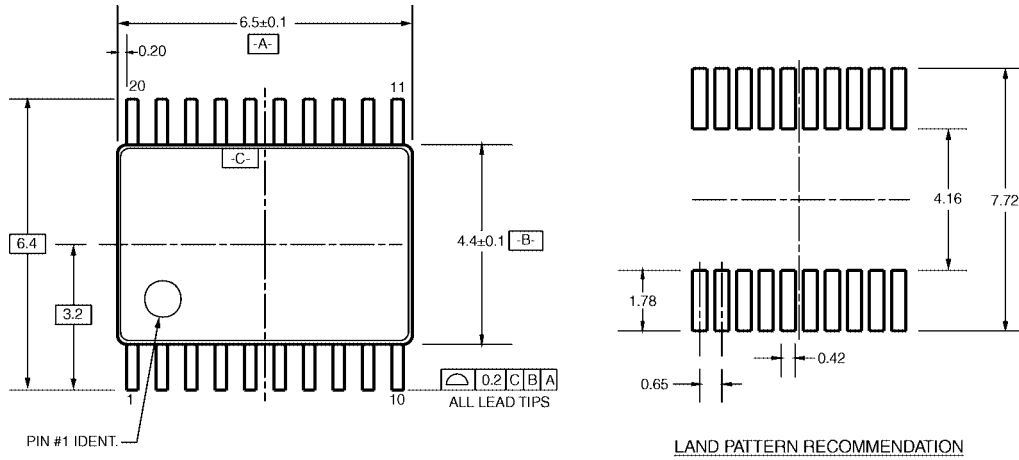

DIMENSIONS ARE IN MILLIMETERS

- NOTES:
 A. CONFORMS TO JEDEC REGISTRATION MO-153, VARIATION AC, REF NOTE 6, DATE 7/93.
 B. DIMENSIONS ARE IN MILLIMETERS.
 C. DIMENSIONS ARE EXCLUSIVE OF BURRS, MOLD FLASH, AND TIE BAR EXTRUSIONS.
 D. DIMENSIONS AND TOLERANCES PER ANSI Y14.5M, 1982.

MTC20RevD1

DETAIL A

**20-Lead Thin Shrink Small Outline Package (TSSOP), JEDEC MO-153, 4.4mm Wide
 Package Number MTC20**

Physical Dimensions inches (millimeters) unless otherwise noted (Continued)

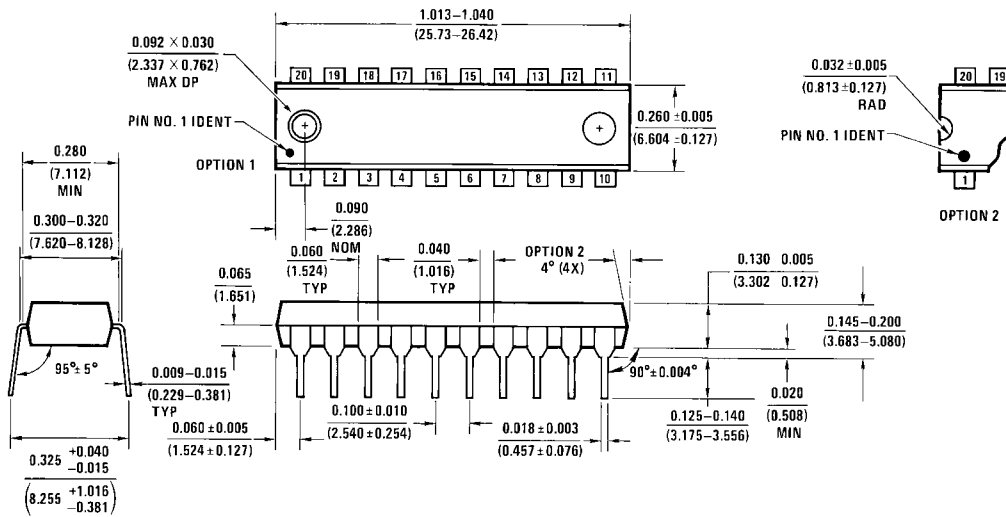

**20-Lead Plastic Dual-In-Line Package (PDIP), JEDEC MS-001, 0.300" Wide
Package Number N20A**

Fairchild does not assume any responsibility for use of any circuitry described, no circuit patent licenses are implied and Fairchild reserves the right at any time without notice to change said circuitry and specifications.

LIFE SUPPORT POLICY

FAIRCHILD'S PRODUCTS ARE NOT AUTHORIZED FOR USE AS CRITICAL COMPONENTS IN LIFE SUPPORT DEVICES OR SYSTEMS WITHOUT THE EXPRESS WRITTEN APPROVAL OF THE PRESIDENT OF FAIRCHILD SEMICONDUCTOR CORPORATION. As used herein:

1. Life support devices or systems are devices or systems which, (a) are intended for surgical implant into the body, or (b) support or sustain life, and (c) whose failure to perform when properly used in accordance with instructions for use provided in the labeling, can be reasonably expected to result in a significant injury to the user.
2. A critical component in any component of a life support device or system whose failure to perform can be reasonably expected to cause the failure of the life support device or system, or to affect its safety or effectiveness.

www.fairchildsemi.com