



Chipsmall Limited consists of a professional team with an average of over 10 year of expertise in the distribution of electronic components. Based in Hongkong, we have already established firm and mutual-benefit business relationships with customers from,Europe,America and south Asia,supplying obsolete and hard-to-find components to meet their specific needs.

With the principle of "Quality Parts,Customers Priority,Honest Operation,and Considerate Service",our business mainly focus on the distribution of electronic components. Line cards we deal with include Microchip,ALPS,ROHM,Xilinx,Pulse,ON,Everlight and Freescale. Main products comprise IC,Modules,Potentiometer,IC Socket,Relay,Connector.Our parts cover such applications as commercial,industrial, and automotives areas.

We are looking forward to setting up business relationship with you and hope to provide you with the best service and solution. Let us make a better world for our industry!



Contact us

Tel: +86-755-8981 8866 Fax: +86-755-8427 6832

Email & Skype: info@chipsmall.com Web: www.chipsmall.com

Address: A1208, Overseas Decoration Building, #122 Zhenhua RD., Futian, Shenzhen, China



Product Features

- Advanced low power CMOS design for 2.7V to 3.6V V_{CC} operation
- Supports 5V input/output tolerance in mixed signal mode operation
- Function compatible with LVT family of products
- Balanced $\pm 24\text{mA}$ output drive
- Typical V_{OGB} (Output Ground Bounce) $< 0.8\text{V}$ at $V_{CC}=3.3\text{V}$, $T_A=25^\circ\text{C}$
- I_{off} and Power Up/Down 3-State support live insertion
- Bus Hold on data inputs eliminates the need for external pull-up/down resistors
- Latch-up performance exceeds 200mA Per JESD78
- ESD protection exceeds JESD 22
 - 2000V Human-Body Model (A114-B)
 - 200V Machine Model (A115-A)
- Industrial Temperature: -40°C to $+85^\circ\text{C}$
- Available Packages (Pb-free & Green available):
 - 48-pin 240-mil wide plastic TSSOP (A)

Product Description

The PI74LVTCH16244 is a non-inverting 16-bit buffer and line driver designed for low-voltage 2.7V to 3.6V V_{CC} operation, with the capability of interfacing to the 5V system environment. This buffer/driver is designed specifically to improve both the performance and density of 3-State memory address drivers, clock drivers, and bus-oriented receivers and transmitters. The device can be used as four 4-bit buffers, two 8-bit buffers, or one 16-bit buffer.

The PI74LVTCH16244 has "Bus Hold" which retains the data input's last valid logic state whenever the data input goes to high-impedance, preventing "floating" inputs and eliminating the need for pull-up/down resistors.

When V_{CC} is between 0 to 1.5V during power up or power down, the device is in the high-impedance state. To ensure the high-impedance state above 1.5V, \overline{OE} should be tied to V_{CC} through a pullup resistor; the minimum value of the resistor is determined by the current sinking capability of the driver.

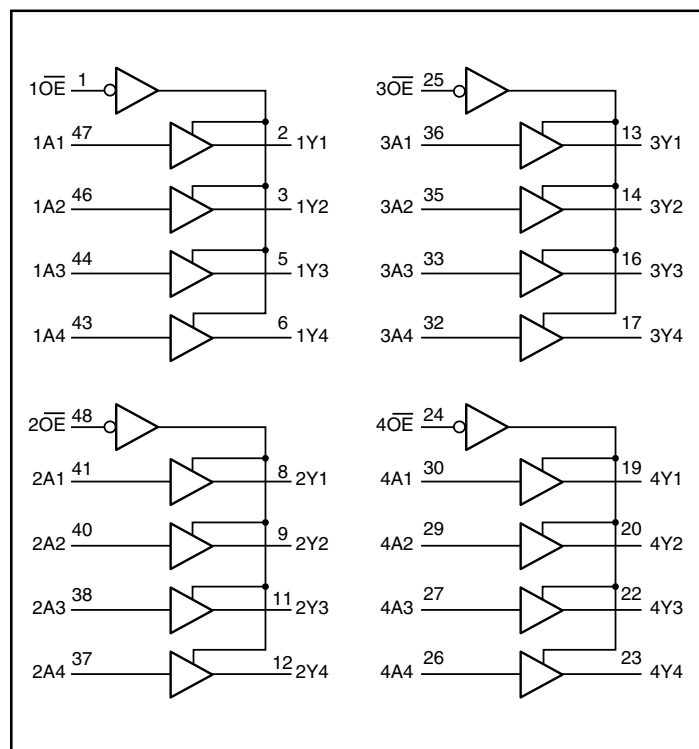
Logic Block Diagram

The device fully supports live-insertion with its I_{off} and power-up/down 3-state. The I_{off} circuitry disables the outputs when the power is off, preventing the backflow of damaging current through the device. Power-up/down 3-state places the outputs in the high-impedance state during power up or power down, preventing driver conflict.

Maximum Ratings

(Above which the useful life may be impaired.
 For user guidelines, not tested.)

Supply voltage range, V_{CC}	-0.5V to +6.5V
Input voltage range, $V_I^{(1)}$	-0.5V to +6.5V
Voltage range applied to any output in the high-impedance or power-off state, $V_O^{(1)}$	-0.5V to +6.5V
Voltage range applied to any output in the active state, $V_O^{(1,2)}$	-0.5V to $V_{CC}+0.5V$
Input clamp current, $I_{IK} (V_I < 0)$	-50mA
Output clamp current, $I_{OK} (V_O < 0)$	-50mA
Continuous Output Current I_O	$\pm 50mA$
Continuous Current through each VCC or GND pin	$\pm 100mA$
Package thermal impedance, $\theta_{JA}^{(3)}$	104°C/W
Storage Temperature range, T_{stg}	-65°C to 150°C

Notes:

Stresses greater than those listed under MAXIMUM RATINGS may cause permanent damage to the device. This is a stress rating only and functional operation of the device at these or any other conditions above those indicated in the operational sections of this specification is not implied. Exposure to absolute maximum rating conditions for extended periods may affect reliability.

1. Input negative-voltage and output voltage ratings may be exceeded if the input and output clamp current ratings are observed.
2. This value is limited to 6.5V maximum.
3. The package thermal impedance is calculated in accordance with JESD51.

Truth Table⁽¹⁾

Inputs		Outputs
\overline{xOE}	xAx	xYx
L	H	H
L	L	L
H	X	Z

Notes:

1. H = High Signal Level
 L = Low Signal Level
 X = Don't Care or Irrelevant
 Z = High Impedance

Product Pin Description

Pin Name	Description
\overline{xOE}	3-State Output Enable Inputs (Active LOW)
xAx	Inputs
xYx	3-State Outputs
GND	Ground
V_{CC}	Power

Product Pin Configuration

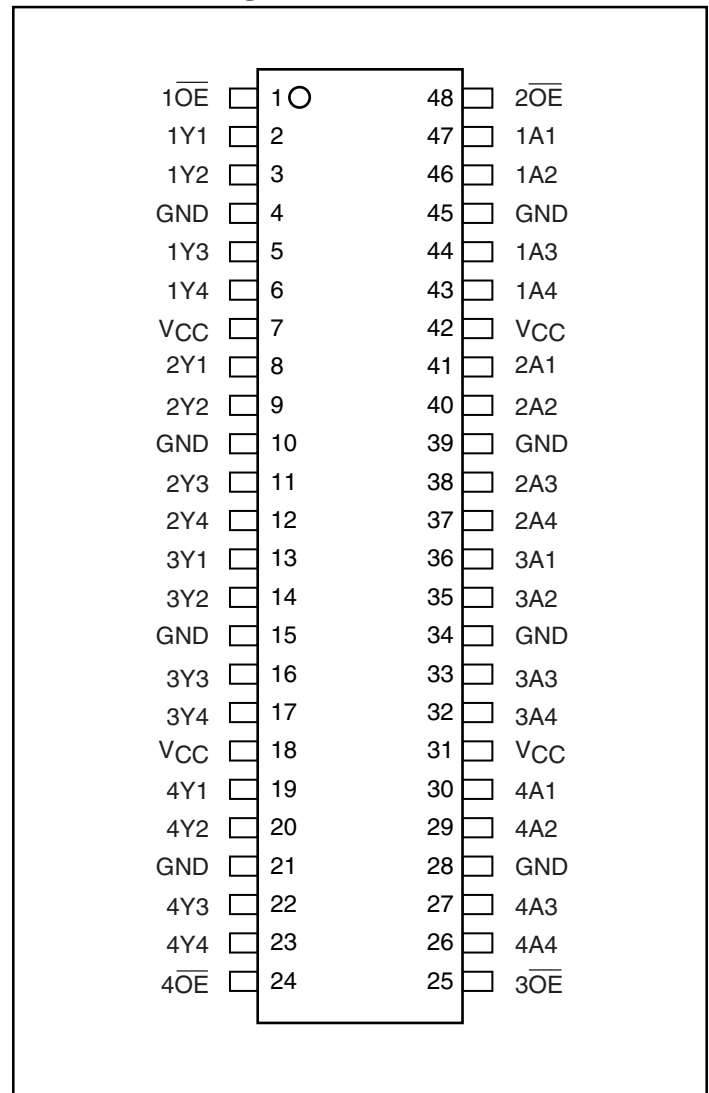

Recommended Operating Conditions⁽¹⁾

		Min.	Max.	Units	
V_{CC}	Supply Voltage	Operating	2.7	3.6	V
V_{IH}	High-level Input Voltage	$V_{CC} = 2.7V$ to $3.6V$	2.0		
V_{IL}	Low-level Input Voltage	$V_{CC} = 2.7V$ to $3.6V$		0.8	
V_I	Input Voltage	0		5.5	
V_O	Output Voltage	High or Low State	0	V_{CC}	
		3-State	0	5.5	
I_{OH}	High-level output current	$V_{CC} = 2.7V$		-12	mA
		$V_{CC} = 3.0V$ to $3.6V$		-24	
I_{OL}	Low-level output current	$V_{CC} = 2.7V$		12	
		$V_{CC} = 3.0V$ to $3.6V$		24	
$\Delta t/\Delta v$	Input transition rise or fall rate			10	ns/V
$\Delta t/\Delta V_{CC}$	Power-up ramp rate		150		$\mu s/V$
T_A	Operating free-air temperature		-40	85	$^{\circ}C$

Notes:

1. All unused inputs must be held at V_{CC} or GND to ensure proper device operation.

DC Electrical Characteristics (Over the Operating Range, $T_A = -40^\circ\text{C} + 85^\circ\text{C}$)

Parameters	Description		Test Conditions		Min.	Max.	Units
V_{IK}	Clamp Diode Voltage		$V_{CC} = 2.7\text{V}$	$I_I = -18\text{mA}$		-1.2V	V
V_{OH}	Output High Voltage		$V_{CC} = 2.7\text{V to } 3.6\text{V}$	$I_{OH} = -100\mu\text{A}$	$V_{CC} - 0.2\text{V}$		
			$V_{CC} = 2.7\text{V}$	$I_{OH} = -12\text{mA}$	2.2		
			$V_{CC} = 3\text{V}$	$I_{OH} = -12\text{mA}$	2.4		
				$I_{OH} = -24\text{mA}$	2.2		
V_{OL}	Output Low Voltage		$V_{CC} = 2.7\text{V to } 3.6\text{V}$	$I_{OL} = 100\mu\text{A}$		0.2	
			$V_{CC} = 2.7\text{V}$	$I_{OL} = 12\text{mA}$		0.4	
			$V_{CC} = 3\text{V}$	$I_{OL} = 12\text{mA}$		0.4	
				$I_{OL} = 24\text{mA}$		0.55	
I_I	Input Leakage Current	Control Inputs	$V_{CC} = 0\text{V to } 3.6\text{V}$	$V_I = 0\text{V to } 5.5\text{V}$		± 5	μA
		Data Inputs	$V_{CC} = 3.6\text{V}$	$V_I = 5.5\text{V}$		± 5	
				$V_I = \text{GND}$			
$I_{I(\text{HOLD})}$	Data Input Hold Current		$V_{CC} = 3\text{V}$	$V_I = 0.8\text{V}$	75		
				$V_I = 2\text{V}$	-75		
			$V_{CC} = 3.6\text{V}^{(1)}$	$V_I = 0 \text{ to } 3.6\text{V}$		± 500	
I_{OFF}	Power Off Output Leakage Current		$V_{CC} = 0\text{V}$	$V_I \text{ or } V_O = 0\text{V to } 5.5\text{V}$		± 5	μA
I_{OZ}	3-State Output Leakage Current		$V_{CC} = 2.7\text{V to } 3.6\text{V}$	$V_O = 0\text{V to } 5.5\text{V}$	± 5		
I_{OZPU}	Power-Up 3-State Current		$V_{CC} = 0\text{V to } 1.5\text{V}$	$V_O = 0.5\text{V to } 5.5\text{V}$, $\overline{OE} = \text{don't care}$		± 5	
I_{OZPD}	Power-Down 3-State Current		$V_{CC} = 1.5\text{V to } 0\text{V}$	$V_O = 0.5\text{V to } 5.5\text{V}$, $\overline{OE} = \text{don't care}$		± 5	
I_{CC}	Quiescent Power Supply Current		$V_{CC} = 2.7\text{V to } 3.6\text{V}$	$V_I = V_{CC} \text{ or } \text{GND}$	$I_O = 0$	100	
				$3.6\text{V} \leq V_I \leq 5.5\text{V}$			
ΔI_{CC}	Increase in I_{CC}		$V_{CC} = 3\text{V to } 3.6\text{V}$	One input at $V_{CC} - 0.6\text{V}^{(2)}$ Other inputs at $V_{CC} \text{ or } \text{GND}$		200	

Notes:

1. This is the maximum bus-hold dynamic current. It is the minimum overdrive current required to switch the input from one state to another.
2. This is the increase in supply current for each input that is at the specified TTL voltage level rather than V_{CC} or GND.

Capacitance

Parameters	Description	Test Conditions	Typ. ⁽¹⁾	Units
C _I	Input Capacitance	V _{CC} = 3.3V, V _I = V _{CC} or GND	3.7	pF
C _O	Output Capacitance	V _{CC} = 3.3V, V _O = V _{CC} or GND	7	
C _{PD}	Power Dissipation Capacitance ⁽²⁾	V _{CC} = 3.3V, V _I = 0V or V _{CC} , f=10 MHz	16	

Notes:

- All typical values are measured at V_{CC} = 3.3V, T_A = 25°C
- C_{PD} is defined as the value of the internal equivalent capacitance which is derived from dynamic operating current consumption (I_{CCD}) at no output loading and operating at 50% duty cycle, C_{PD} is related to I_{CCD} dynamic operating current by the expression:

$$I_{CCD} = (C_{PD})(V_{CC})(f_{IN}) + I_{CCstatic}$$

Switching Characteristics Over Operating Range

Parameters	Description	From (Input)	To (Output)	V _{CC} = 3.3V ±0.3V			V _{CC} = 2.7V		Units
				C _L = 50pF, R _L = 500-ohm			C _L = 50pF, R _L = 500-ohm		
				Min.	Typ. ⁽¹⁾	Max.	Min.	Max.	
t _{PLH}	Propagation Delay	A	Y	1.0	2.5	3.4		3.8	ns
t _{PHL}				1.0	2.5	3.4		3.8	
t _{PZH}	Output Enable Time	\overline{OE}	Y	1.0	2.9	4.2		5.0	
t _{PZL}				1.0	3.0	4.2		5.0	
t _{PHZ}	Output Disable Time	\overline{OE}	Y	1.0	2.5	4.0		4.7	
t _{PLZ}				1.0	2.4	3.9		4.3	
t _{SK(O)}	Output to Output Skew ⁽²⁾					0.5			

Notes:

- All typical values are measured at V_{CC} = 3.3V, T_A = 25°C
- Skew between any two outputs, switching in the same direction.

PARAMETER MEASUREMENT INFORMATION

$V_{CC} = 2.7V$ and $3.3V \pm 0.3V$

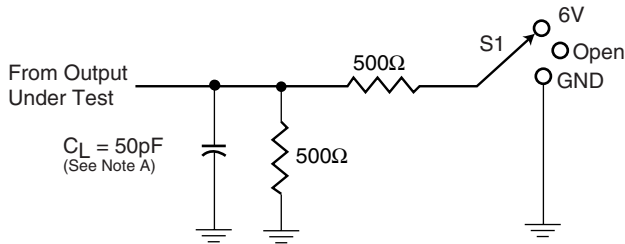

Load Circuit

Test	S1
t_{PLH}/t_{PHL}	Open
t_{PLZ}/t_{PZL}	6V
t_{PHZ}/t_{PZH}	GND

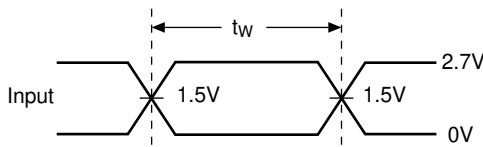

Voltage Waveforms
Pulse Duration

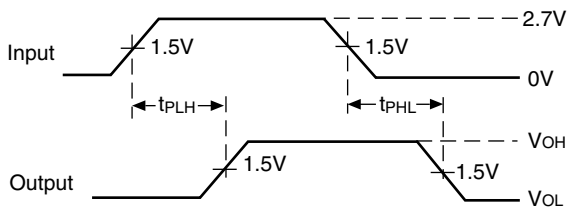

Voltage Waveforms
Propagation Delay Times

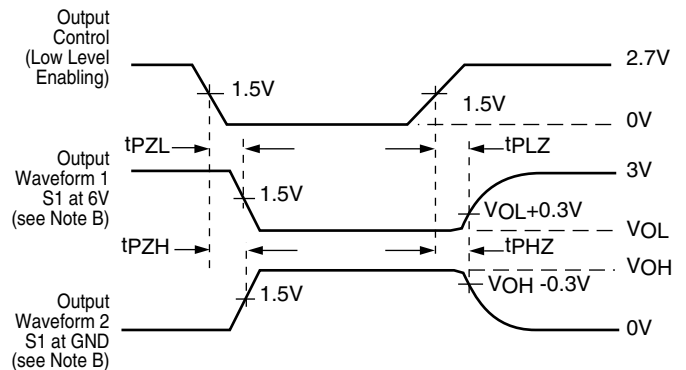

Voltage Waveforms
Enable and Disable Times

Figure 1. Load Circuit and Voltage Waveforms

Notes:

A. C_L includes probe and jig capacitance.

B. Waveform 1 is for an output with internal conditions such that the output is low except when disabled by the output control.

Waveform 2 is for an output with internal conditions such that the output is high except when disabled by the output control.

- All input impulses are supplied by generators having the following characteristics: PRR ≤ 10 MHz, $Z_O = 50\Omega$, $t_R \leq 2.5ns$, $t_F \leq 2.5ns$.
- The outputs are measured one at a time with one transition per measurement.

Packaging Mechanical: 48-pin TSSOP (A)

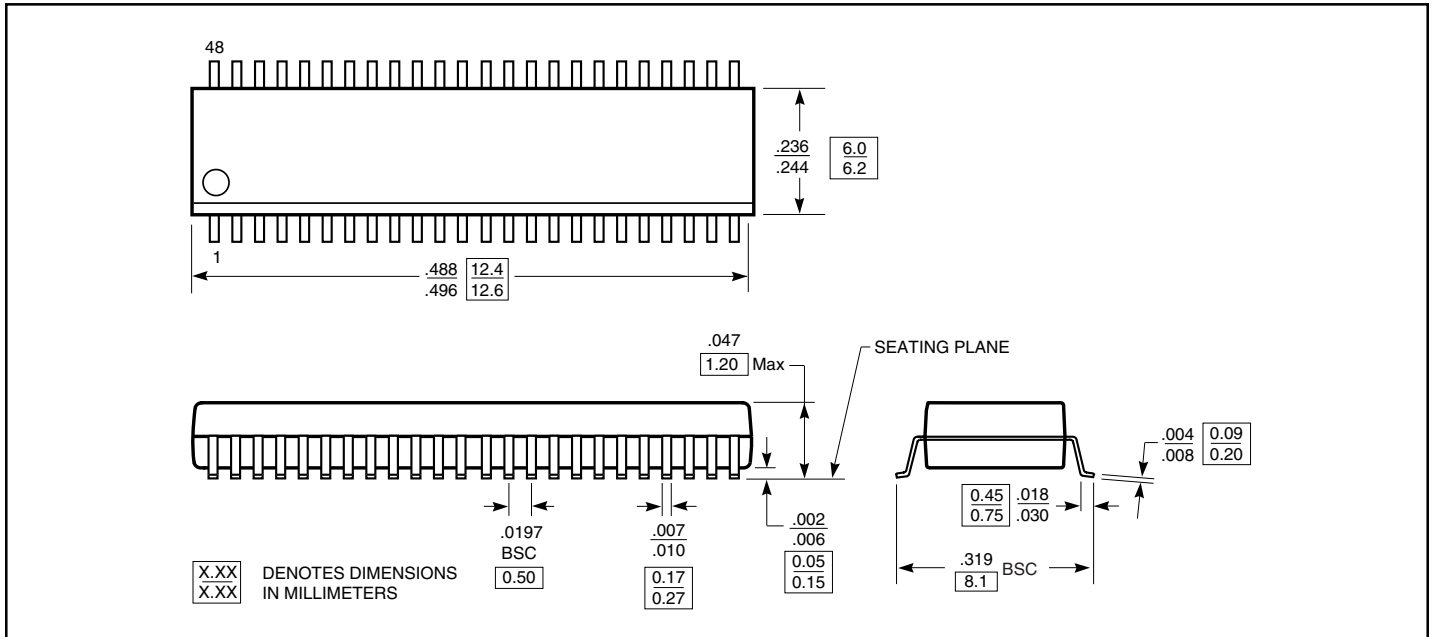

Ordering Information

Ordering Code	Package Code	Package Description
PI74LVTCH16244A	A	48-pin, 240-mil wide plastic TSSOP
PI74LVTCH16244AE	A	Pb-free, 48-pin, 240-mil wide plastic TSSOP

Notes:

- Thermal characteristics can be found on the company web site at www.pericom.com/packaging/
- E = Pb-free & Green
- Adding an X suffix = Tape/Reel